

10,750,000 Shares



### Class B Common Stock

This is an initial public offering of shares of Class B common stock of Bentley Systems, Incorporated.

The selling stockholders identified in this prospectus are selling 10,750,000 Class B shares in this offering. We will not be selling any shares in this offering and will not receive any of the proceeds from the sale of the Class B shares being sold by the selling stockholders.

We have two classes of authorized common stock: Class A common stock and Class B common stock. Upon completion of this offering, the rights of the holders of our Class A common stock and our Class B common stock will be identical, except with respect to voting and conversion rights. Each share of our Class B common stock will be entitled to one vote per share. Each share of our Class A common stock will be entitled to 29 votes per share and is convertible at any time into one share of our Class B common stock. Our Class A common stock will automatically convert into our Class B common stock upon certain transfers. The beneficial owners of our Class A common stock consist primarily of the Bentleys (as defined herein). After giving effect to the Charter Amendments (as defined herein) and following the completion of this offering, the holders of our Class A common stock will hold approximately 57.4% of the voting power of our outstanding capital stock and the Bentley Control Group (as defined herein) will hold or have the ability to control approximately 67.4% of the voting power of our outstanding capital stock. As a result, we will be a “controlled company” within the meaning of the Nasdaq Listing Rules and Nasdaq corporate governance standards. This ownership means that, for the foreseeable future, holders of our Class B common stock will not have a meaningful voice in our corporate affairs and that the control of our company will be concentrated with the Bentley Control Group. For additional information, see the sections titled “Risk Factors — Risks Related to the Offering” and “Management — Controlled Company.”

Prior to this offering, there has been no public market for the Class B common stock. The initial public offering price per share is \$22.00. Our Class B common stock has been approved for listing on The Nasdaq Global Select Market under the symbol “BSY.”

See “Risk Factors” on page 23 to read about factors you should consider before buying shares of our Class B common stock.

**Neither the Securities and Exchange Commission nor any other regulatory body has approved or disapproved of these securities or passed upon the accuracy or adequacy of this prospectus. Any representation to the contrary is a criminal offense.**

	Per Share	Total
Initial public offering price	\$22.00	\$236,500,000
Underwriting discount <sup>(1)</sup>	\$ 1.54	\$ 16,555,000
Proceeds to the selling stockholders <sup>(2)</sup>	\$20.46	\$219,945,000

(1) See the section titled “Underwriting” for additional information regarding compensation payable to the underwriters.

(2) We have agreed to pay certain expenses in connection with this offering on behalf of the selling stockholders, including underwriting discounts and commissions. See the section titled “Underwriting.”

To the extent that the underwriters sell more than 10,750,000 shares of Class B common stock, the underwriters have the option to purchase up to an additional 1,610,991 shares from the selling stockholders at the initial public offering price less the underwriting discount.

One or more funds affiliated with Capital Research Global Investors have indicated an interest in purchasing up to an aggregate of \$40 million in shares of our Class B common stock being offered by the selling stockholders in this offering at the initial public offering price. As this indication of interest is not a binding agreement or commitment to purchase, one or more funds affiliated with Capital Research Global Investors may determine to purchase more, fewer or no shares in this offering or the underwriters may determine to sell more, fewer or no shares to one or more funds affiliated with Capital Research Global Investors. The underwriters will receive the same discount from any shares of Class B common stock purchased by one or more funds affiliated with Capital Research Global Investors as they will from any other shares of Class B common stock sold to the public in this offering.

The underwriters expect to deliver the shares against payment in New York, New York on September 25, 2020.

**Goldman Sachs & Co. LLC**

**BofA Securities**

**RBC Capital Markets**

**Baird**

**KeyBanc Capital Markets**

**Mizuho Securities**

Prospectus dated September 22, 2020.

**TABLE OF CONTENTS**

<a href="#"><u>TRADEMARKS</u></a>	<a href="#"><u>iii</u></a>
<a href="#"><u>PROSPECTUS SUMMARY</u></a>	<a href="#"><u>1</u></a>
<a href="#"><u>RISK FACTORS</u></a>	<a href="#"><u>23</u></a>
<a href="#"><u>CAUTIONARY NOTE REGARDING FORWARD-LOOKING STATEMENTS</u></a>	<a href="#"><u>54</u></a>
<a href="#"><u>MARKET AND INDUSTRY DATA</u></a>	<a href="#"><u>56</u></a>
<a href="#"><u>USE OF PROCEEDS</u></a>	<a href="#"><u>57</u></a>
<a href="#"><u>DIVIDEND POLICY</u></a>	<a href="#"><u>58</u></a>
<a href="#"><u>CAPITALIZATION</u></a>	<a href="#"><u>59</u></a>
<a href="#"><u>SELECTED CONSOLIDATED FINANCIAL DATA AND OTHER DATA</u></a>	<a href="#"><u>61</u></a>
<a href="#"><u>MANAGEMENT’S DISCUSSION AND ANALYSIS OF FINANCIAL CONDITION AND RESULTS OF OPERATIONS</u></a>	<a href="#"><u>72</u></a>
<a href="#"><u>FOUNDERS’ LETTER</u></a>	<a href="#"><u>114</u></a>
<a href="#"><u>BUSINESS</u></a>	<a href="#"><u>131</u></a>
<a href="#"><u>MANAGEMENT</u></a>	<a href="#"><u>164</u></a>
<a href="#"><u>EXECUTIVE AND DIRECTOR COMPENSATION</u></a>	<a href="#"><u>169</u></a>
<a href="#"><u>CERTAIN RELATIONSHIPS AND RELATED PARTY TRANSACTIONS</u></a>	<a href="#"><u>183</u></a>
<a href="#"><u>PRINCIPAL AND SELLING STOCKHOLDERS</u></a>	<a href="#"><u>187</u></a>
<a href="#"><u>DESCRIPTION OF CAPITAL STOCK</u></a>	<a href="#"><u>191</u></a>
<a href="#"><u>SHARES ELIGIBLE FOR FUTURE SALE</u></a>	<a href="#"><u>197</u></a>
<a href="#"><u>MATERIAL U.S. FEDERAL INCOME TAX CONSEQUENCES TO NON-U.S. HOLDERS</u></a>	<a href="#"><u>200</u></a>
<a href="#"><u>UNDERWRITING</u></a>	<a href="#"><u>204</u></a>
<a href="#"><u>LEGAL MATTERS</u></a>	<a href="#"><u>210</u></a>
<a href="#"><u>EXPERTS</u></a>	<a href="#"><u>210</u></a>
<a href="#"><u>WHERE YOU CAN FIND MORE INFORMATION</u></a>	<a href="#"><u>210</u></a>
<a href="#"><u>INDEX TO CONSOLIDATED FINANCIAL STATEMENTS</u></a>	<a href="#"><u>F-1</u></a>

---

You should rely only on the information contained in this prospectus or contained in any free writing prospectus filed with the Securities and Exchange Commission (the “SEC”). Neither we, the selling stockholders nor the underwriters have authorized anyone to provide any information or make any representations other than those contained in this prospectus or in any free writing prospectus we have prepared. We and the underwriters take no responsibility for, and can provide no assurance as to the reliability of, any other information that others may give you. This prospectus is an offer to sell only the shares offered hereby, and only under circumstances and in jurisdictions where it is lawful to do so. The information contained in this prospectus is accurate only as of the date of this prospectus, regardless of the time of delivery of this prospectus or of any sale of the Class B common stock. Our business, financial condition, results of operations, and prospects may have changed since such date.

For investors outside of the United States: neither we, the selling stockholders nor the underwriters have done anything that would permit this offering, or the use of or possession or distribution of this prospectus in any jurisdiction where action for that purpose is required, other than in the United States. You are required to inform yourselves about, and to observe any restrictions relating to, the offering of the shares of Class B common stock and the distribution of this prospectus outside of the United States.

Except as otherwise indicated herein or as the context otherwise requires, references to “Bentley Systems,” the “Company,” “we,” “us,” “our” and similar references refer to Bentley Systems, Incorporated and, where appropriate, its direct and indirect wholly-owned subsidiaries. References to the “Bentleys” refer to Barry J. Bentley, Gregory S. Bentley, Keith A. Bentley, Raymond B. Bentley and Richard P. Bentley, collectively. References to the “Bentley Control Group” refer to the Bentleys and certain of their family members,

trusts or other permitted transferees, as well as all other holders of our Class A common stock in respect of such shares of Class A common stock, who collectively are acting as a group. For a further discussion of the Bentley Control Group, see the section titled “Management — Controlled Company.” References to the “Bentley Family” refer to the Bentleys, certain other family members and trusts and other entities controlled by or primarily for the benefit of the Bentleys and their families.

## TRADEMARKS

This prospectus contains references to our trademarks and service marks and to those belonging to other entities. Solely for convenience, trademarks and trade names referred to in this prospectus may appear without the ® or ™ symbols, but such references are not intended to indicate, in any way, that their respective owners will not assert, to the fullest extent under applicable law, their rights thereto. We do not intend our use or display of other companies' trade names, trademarks or service marks to imply a relationship with, or endorsement or sponsorship of us by, any other companies.

This prospectus contains references to certain data derived from external publications:

- A report prepared by Oxford Economics. The report is copyrighted by the Global Infrastructure Hub Ltd (the "GI Hub"), and is licensed from the GI Hub under a Creative Commons Attribution 3.0 Australia License. To the extent permitted by law, the GI Hub disclaims liability to any person or organization in respect of anything done, or omitted to be done, in reliance upon information contained in the publication. See the section titled "Market and Industry Data;"
- Market analyses prepared by the ARC Advisory Group. All information in the report is proprietary and copyrighted by ARC Advisory Group; and
- A research report commissioned by us entitled "Infrastructure Engineering Software: Potential World-Wide Market Size" prepared by Cambashi Limited ("Cambashi").

## PROSPECTUS SUMMARY

*This summary highlights selected information that is presented in greater detail elsewhere in this prospectus and does not contain all of the information that you should consider in making your investment decision. This summary does not contain all of the information you should consider before investing in our Class B common stock. You should read this entire prospectus carefully, including the sections titled “Risk Factors” and “Management’s Discussion and Analysis of Financial Condition and Results of Operations” and our consolidated financial statements and the related notes included elsewhere in this prospectus, before making an investment decision. Some of the statements in this prospectus constitute forward-looking statements. See the section titled “Cautionary Note Regarding Forward-Looking Statements.”*

### **Our Mission**

Bentley Systems’ mission is to provide innovative software to advance the design, construction, and operations of the world’s infrastructure — sustaining both the global economy and environment, for improved quality of life.

### **Bentley Systems: The Infrastructure Engineering Software Company**

We are a leading global provider of software for infrastructure engineering, enabling the work of civil, structural, geotechnical, and plant engineering practitioners, their project delivery enterprises, and owner-operators of infrastructure assets. We were founded in 1984 by the Bentley brothers. Our enduring commitment is to develop and support the most comprehensive portfolio of integrated software offerings across professional disciplines, project and asset lifecycles, infrastructure sectors, and geographies. Our software enables digital workflows across engineering disciplines, distributed project teams, from offices to the field, and across computing form factors, including desktops, on-premises servers, cloud-native services, mobile devices, and web browsers. We deliver our solutions via on-premise, cloud, and hybrid environments. Our users engineer, construct, and operate projects and assets across the following infrastructure sectors:

- *public works* (including roads, rail, airports, ports, and water and wastewater networks) / *utilities* (including electric, gas, water, and communications). We estimate that this sector represents 52% of the net infrastructure asset value of the global top 500 infrastructure owners based on the 2019 edition of the *Bentley Infrastructure 500 Top Owners*, our annual compilation of the world’s largest infrastructure owners ranked by net depreciated value of their tangible fixed assets;
- *industrial* (including discrete and process manufacturing, power generation, and water treatment plants) / *resources* (including oil and gas, mining, and offshore). We estimate that this sector represents 38% of the global top 500 infrastructure owners’ net infrastructure asset value; and
- *commercial/facilities* (including office buildings, hospitals, and campuses). We estimate that this sector represents 10% of the global top 500 infrastructure owners’ net infrastructure asset value.

Infrastructure assets are among the world’s largest and longest-lived investments, vital to both economic prosperity and environmental health. The quality of a region’s infrastructure directly affects the region’s capacity to meet constituents’ essential needs for water, sanitation, energy, transport, and productive industries. Moreover, infrastructure considerations can affect the rate of global climate change and communities’ vulnerability and resilience to negative climate change outcomes.

Infrastructure is complex due both to its physical scale and to its need for information connectedness at and between every stage of its lifecycle. Infrastructure design requires the structured collaboration of many engineering disciplines, often requiring globally dispersed teams. Infrastructure construction requires a distributed supply chain to reach an often remote location to realize a unique design. Infrastructure operations are mission critical, and require maintaining performance throughput and fitness-for-purpose for multiple generations. The design, construction, and operations of infrastructure require comprehensive solutions that can support and integrate rigorous workflows across professional disciplines in concert over the infrastructure lifecycle.

Our business, comprised of more than 4,000 colleagues, includes a “success force” of more than 900 colleagues with experience and credentials in infrastructure engineering. Our success force, coupled with

36 years of singular focus, has enabled us to create what we believe to be the most comprehensive infrastructure engineering software portfolio available today. Our comprehensiveness creates a formidable competitive advantage by providing our users integrated solutions for infrastructure projects and assets of nearly any type, scale, and complexity.

We address both the project and asset lifecycle phases of infrastructure, each with applications and enterprise information systems. Our Project Lifecycle solutions encompass conception, planning, surveying, design, engineering, simulation, and construction, as well as the collaboration offerings required to coordinate and share the work of interdisciplinary and/or distributed project teams. Our Asset Lifecycle solutions span the operating life of commissioned infrastructure assets, allowing our accounts to manage engineering changes for safety and compliance and to model performance and reliability to support operating and maintenance decisions.

Our revenues are balanced and diversified between engineering and construction contracting firms who work together to deliver the design and construction of capital projects (representing 55% of our 2019 revenues), and their clients, public and private infrastructure asset owners and operators (representing 45% of our 2019 revenues). While engineering and construction contracting firms typically use our Project Lifecycle solutions, owner-operators are often involved in engineering and management for many of their own projects, and so can be users of our Project Lifecycle as well as our Asset Lifecycle solutions.

Our company's "Advancing Infrastructure" tagline reflects our enduring track record in successfully leveraging new technologies to improve and integrate the design, construction, and operations of infrastructure, leading to our infrastructure digital twins. An infrastructure digital twin is a cloud-native 4D digital representation of a physical project and resulting asset, incorporating its underlying engineering information, that is applied to model, simulate, analyze, chronicle, and predict its performance over time. By adding digital twin services to our existing solutions, our users can more fully extend digital workflows across project delivery and asset performance, increasing the value of infrastructure engineers' work.

We are the only infrastructure engineering software vendor to lead in market share in categories related to both the project and the asset lifecycle phases in the most recent rankings by The ARC Advisory Group ("ARC"). In August 2019, for *Engineering Design Tools for Plants, Infrastructure, and BIM* (building information modeling), ARC ranked us #2 overall, as well as #1 in each of Electric Transmission & Distribution and Communications and Water/Wastewater Distribution. In August 2019, ARC ranked us #1 in its inaugural market share study for Collaborative BIM. In December 2019, for *Asset Reliability Software & Services*, ARC ranked us #1 overall for software, as well as #1 in each of Transportation, Oil and Gas, and Electric Power Transmission and Distribution.

During the last two years, Microsoft recognized us as its 2019 "CityNext Partner of the Year" (citing our Azure-hosted *ProjectWise* for the Mumbai Trans Harbour Sea Link in India), its 2018 "CityNext Partner of the Year" (citing our Azure-hosted *ProjectWise* and *AssetWise* for the Klang Valley MRT in Kuala Lumpur, Malaysia), and a Finalist for the 2019 "Mixed Reality Partner of the Year Award" (citing our SYNCHRO XR 4D construction modeling application for the new HoloLens 2 device). Also, according to Microsoft, in 2019 we were one of the top 25 companies in terms of Azure usage globally.

We have spent decades cultivating trusted relationships with the largest global infrastructure engineering organizations. Our accounts include 90% of the top 250 of the *ENR 2019 Top 500 Design Firms* and 64% of the 2019 *Bentley Infrastructure 500 Top Owners*. The *ENR 2019 Top 500 Design Firms* is authored by Engineering News-Record ("ENR") and the *Bentley Infrastructure 500 Top Owners* is authored by us. These rankings consist of substantially distinct account lists (with the exception of a *de minimis* number of overlapping accounts), and such accounts collectively represented 42% of our total revenues for the year ended December 31, 2019. Our solutions are, in general, mission critical both for our accounts and for our professional users and foster a high degree of loyalty, with 80% of our 2018 and 2019 total revenues coming from accounts of more than ten years' standing, and 87% of our 2018 and 2019 total revenues coming from accounts of more than five years' standing.

## Revenues by Account Type and Size

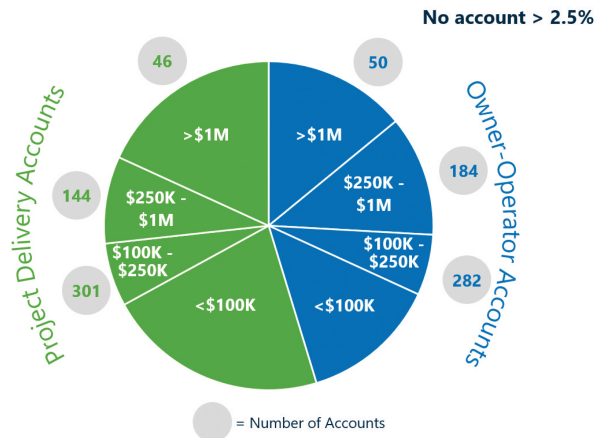

\* All figures as of December 31, 2019. All figures calculated using ASC 606. Chart segment sizing corresponds to underlying % of 2019 revenue.

We are a significant software vendor to major infrastructure engineering organizations. In 2018 and 2019, 88 and 96 accounts, respectively, each contributed over \$1 million to our revenues, representing 31% and 32% of our revenues, respectively. 50% of our 2018 revenues and 53% of our 2019 revenues came from 376 accounts and 424 accounts, respectively, each contributing over \$250,000 to our revenues. During 2018 and 2019, we served 36,718 and 34,127 accounts, respectively, and for the six months ended June 30, 2019 and 2020, we served 31,130 and 31,745 accounts, respectively. We determine “accounts” based on distinct contractual and billing relationships with us. Affiliated entities of a single parent company may each have an independent account with us. We have historically offered, and have in recent years enhanced, volume discount programs to incentivize such affiliated entities to consolidate their contractual relationships with us, resulting in a reduction to the number of distinct accounts so defined. No single account or group of affiliated accounts provided more than 2.5% of our 2018 or 2019 revenues.

Our business is comprehensively global. In 2019 the majority of our revenues were generated across 171 countries outside the United States, with 32.1% from EMEA and 19.5% from APAC. We have purposefully invested and are fully established in developing international markets where rapid infrastructure growth will continue to present compelling opportunities for us to scale efficiently. In particular, Greater China, which we define as the Peoples’ Republic of China, Hong Kong and Taiwan, and where we now have over 200 colleagues, has become one of our largest (among our top five) and fastest growing regions as measured by revenue, contributing just over 5% of our 2019 revenues.

In 2019, we generated subscription revenues of \$608 million, total revenues of \$737 million, net income of \$103 million and Adjusted EBITDA of \$188 million, and for the six months ended June 30, 2020, we generated subscription revenues of \$328 million, total revenues of \$379 million, net income of \$69 million and Adjusted EBITDA of \$116 million. Our business is cash-efficient, with approximately 70% of our revenues billed in advance, and a global tax rate of under 20%. For additional information on our financial results, key metrics, and non-GAAP financial metrics, see the section titled “Management’s Discussion and Analysis of Financial Condition and Results of Operations — Key Business Metrics.”

### **Our Solutions**

We offer solutions for enterprises and professionals across the infrastructure lifecycle. Our Project Delivery and Asset and Network Performance solutions are systems provided via cloud and hybrid environments, developed respectively to extend enterprise collaboration during project delivery, and to manage and leverage engineering information during operations and maintenance. Our Design Integration and Digital Cities solutions are primarily desktop applications and cloud-provisioned solutions for

professional practitioners and workgroups. Our cloud-native Digital Twins solutions introduce digital workflows, which can span our Project Lifecycle and Asset Lifecycle solutions.

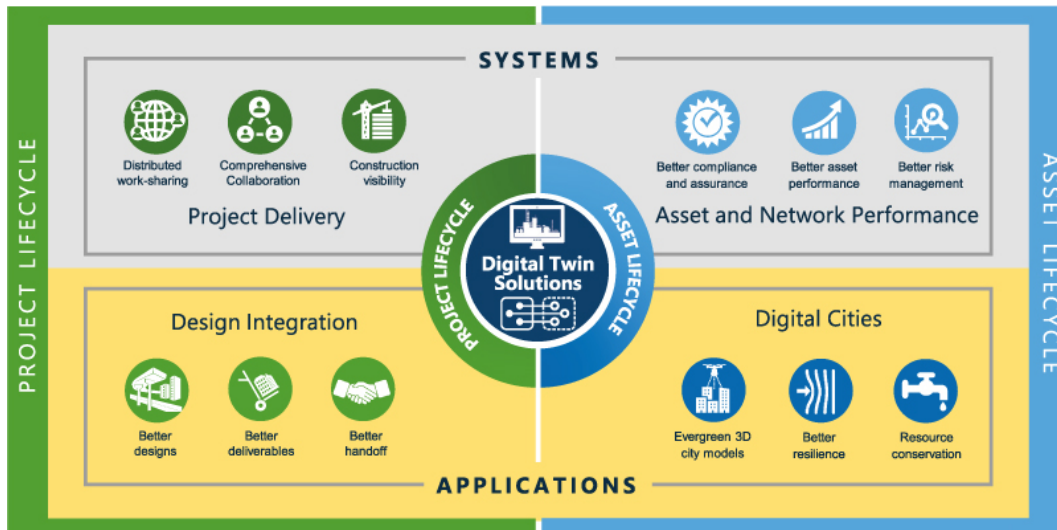

**Project Lifecycle Solutions.** Our Project Lifecycle solutions span conception, planning, surveying, design, simulation, and construction, as well as the collaboration software services required to coordinate and share the work of interdisciplinary and/or distributed project teams.

**Design Integration.** Our Design Integration solutions consist of modeling and simulation applications. Our modeling applications are domain-specific authoring tools used by professionals for the 3D design and documentation of infrastructure assets. Our simulation applications enable engineers to analyze the functional performance of the designs created with our modeling applications (or those of competitive vendors), preferably in iterative digital workflows, to improve engineering outcomes and to ensure compliance with design codes.

Benefits of our Design Integration applications to infrastructure engineers include:

- **Better designs.** Our modeling and simulation applications work together to improve infrastructure engineering quality, for instance to eliminate “clashes” across respective disciplines’ work. Each application is for a specific purpose (asset-type or discipline; for example, OpenRoads for roadway design) and supports corresponding asset-specific engineering workflows (for example, the workflow a civil engineer would use in designing a road);
- **Better deliverables.** Our applications share a common modeling environment to enable streamlined coordination and production of multi-discipline documentation; and
- **Better handoff.** Our comprehensive modeling environment and our supplemental cloud services enable projects to enrich information sharing (and to minimize problematic translations) across project delivery processes.

**Project Delivery.** Our Project Delivery solutions support information and document management, engineering-specific collaboration and work-sharing for distributed project teams and enterprises, and construction planning, modeling and execution. The scope of these solutions is not limited to users of only our own design applications.

Our 4D construction modeling software spatially and temporally integrates a project’s 3D engineering models into its construction schedules to assess sequencing strategies and to visualize and understand planned and actual progress over the project timeline. Our solutions also enable project delivery teams to optimally define and manage discrete engineering, construction, and installation work packages, including the construction trades’ “workforce planning,” which considers crafts and materials by day and zone. For work



packages which increasingly take advantage of modular offsite fabrication and manufacturing, our software manages and enables 4D visualization of the necessary spatial and logistical interfaces.

Benefits of our Project Delivery solutions to project delivery enterprises include:

- *Distributed work-sharing:* Our solutions incorporate the rigorous workflow protocols required for structured coordination across engineering and construction supply chains, enabling global sourcing for integrated project delivery, while maximizing economics, quality, and safety;
- *Comprehensive collaboration:* Our software leverages cloud and hybrid environments to streamline the aggregation, distribution, and interaction for project deliverables, ensuring that the right project participants have the right information in the right format at the right time, including at the project site and on every device; and
- *Construction visibility:* Our solutions' broad span and continuous detail across design integration, construction modeling and work packaging, and mixed-reality 4D visualization, advances predictability, accountability, and safety throughout the construction process.

**Asset Lifecycle Solutions.** Our Asset Lifecycle solutions span the operating life of commissioned infrastructure assets, capturing and managing changes to engineering models and enterprise information for compliance and safety, and to model performance and reliability to support operating and maintenance decisions.

*Asset and Network Performance.* Our Asset and Network Performance solutions are used to manage engineering information and geospatial relationships for operating and provisioning infrastructure across all sectors, including linear networks for transportation and energy transmission and distribution. Our asset performance modeling provides the needed analytical context for “right-time” data, including from Internet of Things (“IoT”) sensor capabilities, to yield actionable insights.

Benefits of our Asset and Network Performance solutions for owner-operators include:

- *Better compliance and assurance:* Our systems intrinsically enforce the rigor appropriate for operating infrastructure assets in order to provide dependable visibility into the impact of changes;
- *Better asset performance:* Our solutions include operational dashboards that provide decision support insights to maintain and improve throughput and reliability; and
- *Better risk management:* Our solutions include predictive analytics that identify potential problems before they occur, and ensure the accessibility of best-available engineering information and models for mitigation and resilience.

*Digital Cities.* Our Digital Cities solutions incorporate reality modeling (leveraging drone and mobile mapping “survey” inputs) and geospatial context to continuously capture as-operated infrastructure conditions at city and regional scale. Our offerings support department-level applications for municipal engineering, such as simulation of pedestrian and vehicle traffic, and water and drainage systems.

Benefits of our Digital Cities solutions to cities, regions, and their constituents include:

- *Evergreen 3D city models:* Our reality modeling software maintains engineering-ready 3D models, incorporating incrementally updated surveys, and thus ensures that engineering departments can rely on up-to-date geospatial context for digital workflows;
- *Better resilience:* Our solutions can integrate geotechnical, structural/seismic, and hydrological engineering modeling with evergreen 3D city models to harden infrastructure from flood and other natural hazards, and to apply engineering simulations for mitigation and emergency response; and
- *Resource conservation:* Taking full advantage of our solutions can significantly increase efficiency and reduce waste. For instance, our water network modeling tools, applied to compare as-designed specifications to observed flows and pressures, can help to non-invasively locate subsurface water network leaks.

### *Infrastructure Digital Twins.*

Our digital twins offerings enable our users to create and curate cloud-native 4D digital representations of physical projects and resulting assets, incorporating underlying engineering information, and then to model, simulate, analyze, chronicle, and predict performance over time. Using digital twins, our users can more fully extend digital workflows across project delivery and asset performance, increasing the value of infrastructure engineers' work.

Benefits of our digital twins solutions to project delivery firms and owner-operators include:

- *Advanced insights.* For project delivery, digital twins can reveal insights beyond what would be visible with traditional workflows; for example, a digital twin can show 3D heat maps highlighting where changes in a design have been unusually pervasive, indicating possible design flaws. For asset performance, such insights from digital twins can be used to evaluate different strategies for optimizing operational efficiencies and throughput;
- *Predictive analytics.* For project delivery, digital twins and machine learning can compare the progress of a current project with similar projects that have been previously completed, and identify in advance potential bottlenecks, in time to take corrective action. For asset performance, a digital twin can track observations from various operational inputs against design intelligence to predict future failures and recommend maintenance actions to minimize downtime;
- *Continuous and comprehensive design reviews.* For project delivery, digital twins can aggregate and align design models and data from all sources “on the fly” (without interruptions for translations, and without specialized software) to present immersive 3D status visualization in a web browser for any authorized stakeholder to participate in ongoing interactive design reviews; and
- *Convergence of OT, IT, and now ET.* Infrastructure owner-operators are increasingly able to instrument their assets with IoT sensors, producing torrents of Operational Technology (“OT”) data that are difficult to interpret. Software advances in Information Technology (“IT”) can in turn make data from enterprise transaction systems, such as maintenance work order history, accessible for analytics. But even OT and IT together cannot inform decisions for improved asset performance as sufficiently as when combined with accessibility to comparable analytics from the assets' engineering models, which we refer to as the Engineering Technology (“ET”). Infrastructure digital twins notably enable the convergence of ET with OT and IT. With infrastructure digital twins, the design intent (the “digital DNA” captured in the digital twins' engineering models and simulations) can serve as a baseline for comparison to IoT-monitored “as-operated” performance, in light of the asset's operations and maintenance history stored in IT systems, to enable integrated analytics to provide timely insights and recommended actions to optimize safety and performance.

### **Comprehensiveness of Our Offerings**

Our offerings are comprehensive across professional disciplines, lifecycle stages, infrastructure sectors, and geographies, resulting in what we believe to be durable competitive advantages:

***Professional Disciplines.*** Each infrastructure project requires seamless and deep collaboration among professional disciplines, which can include civil, structural, geotechnical, and process engineers, architects, geospatial professionals, city and regional planners, contractors, fabricators, and operations and maintenance engineers. Our open modeling and open simulation applications facilitate iterative interactions between disciplines and coordination across project participants. Additionally, we believe our collaboration systems lead the market in managing infrastructure engineering firms' preferred work-in-progress workflows.

***Lifecycle Stages.*** Both project delivery enterprises and owner-operators benefit from our solutions which enable digital workflows to extend between project and asset lifecycles, from design to construction and ultimately asset management. This capability allows our users' digital engineering models to be leveraged as the context for real-time condition monitoring to achieve better and safer operations and maintenance.

***Infrastructure Sectors.*** Most major engineering and project delivery firms pursue an ever-changing mix of projects across the public works/utilities, industrial/resources, and commercial/facilities sectors and for flexibility tend to favor an infrastructure engineering software vendor whose portfolio correspondingly

spans their full breadth. This comprehensiveness provides diversification for our own business, as an incidental advantage. For example, when there have been cyclical downturns in the primarily privately-financed industrial/resources and commercial/facilities sectors, we have historically witnessed offsetting counter-cyclical government investment in public works/utilities.

**Geographies.** While design codes may vary by country, infrastructure purposes and engineering practices are fundamentally the same throughout the world, which makes it possible for our infrastructure modeling applications to be used globally. Our offerings are available in most major languages, supporting country-specific standards and conventions. Our development teams are also globally dispersed, due in part to acquisitions made in various countries, but also to provide any needed last mile localization of our applications. Our global comprehensiveness enables our project delivery accounts to compete more efficiently across geographic markets, thus also providing global supply-chain sourcing choices for owners.

### **Our Opportunity**

We believe we are successful and well-established in enterprise-level relationships with the world's largest infrastructure engineering organizations, including both project-delivery contracting firms and owner-operators. Today, we address a significant market opportunity, which we refer to as our serviceable addressable market ("SAM"). We estimate 66% of our SAM is in our existing accounts. We further estimate our global SAM is approximately \$9.5 billion, \$6.1 billion of which is attributable to project delivery firms and \$3.4 billion of which is attributable to owner-operators. Further, of our \$9.5 billion SAM, approximately \$1.6 billion is in Greater China.

We also view our market opportunity in terms of the total addressable market ("TAM"), which we believe we can address over the long term. We believe that digital progress in the engineering of constructed infrastructure has to date lagged behind other substantial economic domains, and in particular has lagged behind digital progress — as reflected in spending on engineering software — in the engineering of manufactured products. Cambashi estimates that if engineering software spending would become as intensive in infrastructure engineering as in product engineering, global infrastructure engineering software spending, or our TAM, would be \$29.2 billion. We believe that over time our current SAM of \$9.5 billion will approach our estimated TAM of \$29.2 billion. We also believe that both our SAM and our TAM will further expand over time with the growth of infrastructure spending. See the section titled "Business — Our Opportunity."

### **Our Growth Strategies**

We employ the following growth strategies to address the infrastructure engineering software market opportunities:

- **Accretion within existing accounts.** We believe we can further penetrate our existing accounts by broadening their use of our portfolio. There are three primary mechanisms for this expansion:
  - *New commercial formulations.* We continually innovate with new commercial formulations to align the use of our software to the needs of our users. We believe the flexibility in our commercial models and deployment options will allow our accounts to grow usage continuously;
  - *Automating user engagement.* We employ various technologies to drive user engagement. We will continue to leverage these interactive technologies to virtually assist our users and drive engagement across our software offerings; and
  - *Adding new offerings.* We have a history of building and maintaining leadership in infrastructure software engineering comprehensiveness and intend to continue to innovate and develop our software offerings. We intend to continue to develop and integrate new products and capabilities over time;
- **Focusing on Asia.** We believe Asia represents a large market opportunity and will continue to do so over the foreseeable future. We intend to continue investing in strategies to enhance our market position in Asia;

- **Increasing inside sales.** We will continue to expand our global inside sales resources and to multiply their reach and effectiveness with superior digital tools to convert leads and to provide the self-service administration that engineering practitioners prefer; and
- **Digital co-ventures.** We have forged substantial alliances with other major participants in the infrastructure engineering supply chain (for example, Topcon, Siemens, and Microsoft), primarily to jointly develop and offer digital twin cloud services that extend the scope of our software.
- **Investing in digital integrator businesses.** We intend to invest in and grow a portfolio of businesses operating outside of our core software business with the objective of cultivating an ecosystem of relatively service-intensive, yet profitable, digital integrator businesses that stimulate pull-through demand for our solutions.

### **Recent Developments**

#### ***Impact of COVID-19***

In March 2020, the World Health Organization declared a global pandemic related to the rapidly growing outbreak of the disease COVID-19, caused by a novel strain of coronavirus, SARS-CoV-2. The COVID-19 outbreak and certain preventative or protective actions that governments, businesses and individuals have taken in respect of COVID-19 have resulted in global business disruptions.

In response to the COVID-19 pandemic, we implemented a number of initiatives to ensure the safety of our colleagues and enable them to move to a work from home environment seamlessly and continue working effectively. These initiatives included providing our colleagues with necessary equipment, making certain that all colleagues had means of video and audio communications online, and guaranteeing that our network bandwidth was sufficient. Our business model is such that we had minimal disruption to our ability to deliver our solutions to accounts, and we did not have any loss of productivity during this transition. Almost all of our colleagues have been working from home since March 16, 2020, with a minority of our colleagues working in our office environments on a voluntary basis and abiding by appropriate distancing and sanitary regulations for their region. We communicated regularly and provided on-demand learning and support to our colleagues throughout the transition period. Based on a May 2020 internal survey, a majority of our colleagues are confident in the decisions that Bentley leadership is making regarding employee well-being and safety during this pandemic, and a majority of our colleagues believe that Bentley's response to and communication regarding COVID-19 has been timely and helpful.

The impact of the pandemic on our financial performance has been modest; our revenues have continued to grow given the mission critical nature of our solutions. For the months of March and April, our accounts' usage of our applications was down approximately 3-5% when compared to levels from the same periods in 2019; however, these metrics returned to pre-COVID-19 levels in June 2020. The modest and temporary dip in usage had limited impact on our recurring revenues, which are comprised primarily of longer term contracts. The growth of our revenues from perpetual licenses and professional services has been impacted as selected accounts have shifted spend to subscription solutions or delayed new projects.

Moreover, we were quick to find ways to support our accounts and users, including the launch of a "Bentley Has Your Back" campaign to help our accounts take full advantage of their Bentley software. This campaign included producing over 50 self-help documents, 20 webinars, and several messages guiding users on various topics including how Bentley's solutions should be configured when working with limited bandwidth, how to use a SmartTV as a monitor, and how to leverage specific offerings such as ProjectWise to facilitate collaboration in their own businesses in remote working environments. This guidance and assistance was well received by accounts and we believe helped maximize usage during the observed trough in March and April.

We have also taken measures to reduce selected operating expenses, including various costs associated with travel and facilities. Much of those resulting savings have been or will be re-invested in a portfolio of businesses outside of our core software business, with the objective of cultivating an ecosystem of digital integrator businesses.

Our business benefits from a resilient business model backed by industry tailwinds and a strong financial profile. We believe that significant public and private investment will continue to drive spend for infrastructure globally, which will continue to drive demand for our solutions. Additionally, we do not have any material account concentration; no single account or group of affiliated accounts, represented more than 2.5% of our revenues for the year ended December 31, 2019. As of June 30, 2020, we had \$126 million of cash and cash equivalents, and \$293 million was available under the Credit Facility (as defined below).

***Relationship with Siemens AG (“Siemens”)***

As discussed in the section titled “Certain Relationships and Related Party Transactions — Our Relationship with Siemens AG — Common Stock Purchase Agreement,” we, and the Bentley family members party to the Common Stock Purchase Agreement, entered into the Common Stock Purchase Agreement with Siemens in September 2016, pursuant to which we and they have granted Siemens a right of first refusal with respect to certain deemed liquidation events, offers, sales or certain issuances of our capital stock, and with respect to certain transfers of our capital stock by the Bentley family members party thereto. Pursuant to the terms of the Common Stock Purchase Agreement, Siemens’ right of first refusal expires upon the effectiveness of a registration statement in connection with an underwritten initial public offering. Siemens contends that this right of first refusal applies to sales of common stock in an initial public offering by the Company or the Bentley family members party to the Common Stock Purchase Agreement. While we disagree with Siemens’ contention, our initial public offering of Class B common stock will be exclusively by existing holders whose transfers of capital stock are not subject to Siemens’ right of first refusal, and we have not included any shares to be issued by the Company or any shares held by the Bentley family members party to the Common Stock Purchase Agreement in the offering pursuant to this prospectus.

Additional information regarding our relationship with Siemens is discussed in the section titled “Certain Relationships and Related Party Transactions — Our Relationship with Siemens AG.”

***Potential for Post-IPO Follow-On Offering***

Following the effectiveness of the registration statement of which this prospectus forms a part, Siemens’ right of first refusal will terminate. Following the completion of this offering, we intend to evaluate opportunities to then undertake a primary offering of our Class B common stock by the Company, subject to the lock-up agreement entered into with the underwriters in this offering, prevailing market conditions and applicable securities laws. We have not engaged in any formal discussions regarding any such offering and we have not undertaken any steps to pursue such an offering. The Company lock-up contained in the underwriting agreement entered into by us with the underwriters in this offering will permit us and selling stockholders to sell shares of Class B common stock in an aggregate amount equal to up to 20% of our total Class B common stock outstanding at such time beginning on December 1, 2020, and such lock-up agreement expires 180 days following the date of this prospectus. See the section titled “Underwriting” for additional information regarding our lock-up agreement with the underwriters.

***New Term Loan and Payment of Special Dividend***

On September 2, 2020, we entered into an amendment (“First Amendment”) to the Amended and Restated Credit Agreement, dated as of December 19, 2017, by and among Bentley Systems, PNC Bank National Association, as administrative agent, and the lenders party thereto (the “Credit Facility”). The First Amendment provided for a \$125.0 million senior secured term loan with a maturity of December 18, 2022 (the “New Term Loan”) and included certain other amendments, including the addition of a mandatory prepayment provision requiring us to prepay borrowings under the Credit Facility in an aggregate amount equal to the net proceeds from any underwritten public offering by the Company, which prepayment shall be applied, first, to the New Term Loan and, second, to any borrowings outstanding under the revolving facility under the Credit Facility without reducing the revolving commitments thereof.

On August 28, 2020, our Board of Directors declared a special dividend of \$1.50 per share of our common stock (approximately \$390 million in the aggregate) (the “Special Dividend”) and a regular quarterly dividend of \$0.03 per share of our common stock. The record date for each of the Special Dividend and the regular quarterly dividend was August 31, 2020 and the Special Dividend and the regular quarterly dividend were payable on September 2, 2020 and September 3, 2020, respectively, subject, in the case of the

Special Dividend, to the entry into the First Amendment. We used borrowings under the New Term Loan and under the revolving facility under the Credit Facility to pay such dividends.

### **Risk Factor Summary**

Investing in our Class B common stock involves a high degree of risk. You should carefully consider all information in this prospectus prior to investing in our Class B common stock. These risks are discussed more fully in the section titled “Risk Factors.” These risks and uncertainties include, but are not limited to, the following:

- Demand for our software solutions is subject to volatility in our accounts’ underlying businesses, which includes infrastructure projects that typically have long timelines;
- The majority of our revenues and an increasing percentage of our operations are attributable to operations outside the United States, and our results of operations therefore may be materially affected by the legal, regulatory, social, political, economic and other risks of foreign operations;
- Recent and potential tariffs imposed by the U.S. government or a global trade war could increase the cost of our products and services and the cost of conducting our business, which could harm our business, financial condition and results of operations;
- Global economic conditions may negatively impact our business, financial results and financial condition;
- Decreased investment by APAC, including China, may have a negative effect on our business;
- The ongoing global coronavirus outbreak could materially and adversely affect our business;
- The sales cycle for some of our solutions can be long and unpredictable and requires considerable time and expense, which may cause our results of operations to fluctuate;
- If we do not keep pace with technological changes, and effectively market our new product solutions, our solutions may become less competitive and our business may suffer;
- Interruptions in the availability of server systems or communications with Internet, third-party hosting facilities or cloud-based services, or failure to maintain the security, confidentiality, accessibility or integrity of data stored on such systems, could harm our business or impair the delivery of our managed services;
- If our security measures or those of our third-party cloud data hosts, cloud computing platform providers, or third-party service partners, are breached, and unauthorized access is obtained to an account’s data, our data or our IT systems, our services may be perceived as not being secure, accounts may curtail or stop using our services, and we may incur significant legal and financial exposure and liabilities;
- We face intense competition;
- We may not be able to increase the number of new subscription-based accounts or cause existing accounts to renew their subscriptions, which could have a negative impact on our future revenues and results of operations;
- Our revenue recognition policy and other factors may create volatility in our financial results in any given period and make them difficult to predict;
- Failure to protect our intellectual property rights could impair our ability to protect our proprietary technology and our brand;
- We depend on our senior management team and other key personnel, and we could be subject to substantial risk of loss if any of them terminate their relationship with us;
- Our share price may be volatile, and you may be unable to sell your shares at or above the offering price, if at all. Market volatility may affect the value of an investment in our Class B common stock and could subject us to litigation;

- There has been no public market for our Class B common stock prior to this offering, and you may not be able to resell our shares at or above the price you paid, or at all. In addition, the limited public float of our Class B common stock following this offering could adversely impact the trading price of our Class B common stock; and
- The dual class structure of our common stock has the effect of concentrating voting control with the Bentley Control Group.

### **Channels for Disclosure of Information**

Investors, the media, and others should note that, following the effectiveness of the registration statement of which this prospectus forms a part, we intend to announce material information to the public through filings with the SEC, the investor relations page on our website, press releases, public conference calls and webcasts.

The information disclosed by the foregoing channels could be deemed to be material information. As such, we encourage investors, the media, and others to follow the channels listed above and to review the information disclosed through such channels.

Any updates to the list of disclosure channels through which we will announce information will be posted on the investor relations page on our website.

### **Corporate Information**

Bentley Systems, Incorporated was incorporated in Delaware in 1987. We were originally incorporated in California in 1984 upon our founding. Our principal offices are located at 685 Stockton Drive, Exton, PA 19341, and our telephone number is (610) 458-5000. Our website address is [www.bentley.com](http://www.bentley.com). Information contained on, or that can be accessed through, our website does not constitute part of this prospectus and the inclusion of our website address in this prospectus is an inactive textual reference only.

### **Emerging Growth Company**

The Jumpstart Our Business Startups Act (the “JOBS Act”) was enacted in April 2012 with the intention of encouraging capital formation in the United States and reducing the regulatory burden on newly-public companies that qualify as “emerging growth companies.” We are an “emerging growth company” within the meaning of the JOBS Act. As an “emerging growth company,” we intend to take advantage of certain exemptions from various public reporting requirements, including the requirement that our internal control over financial reporting be audited by our independent registered public accounting firm pursuant to Section 404 of the Sarbanes-Oxley Act of 2002 (the “Sarbanes-Oxley Act”), certain requirements related to the disclosure of executive compensation in this prospectus and in our periodic reports and proxy statements, and the requirement that we hold a non-binding advisory vote on executive compensation and any golden parachute payments. Additionally, as an “emerging growth company” we are required to have only two years of audited financial statements and only two years of related selected financial data and Management’s Discussion and Analysis of Financial Condition and Results of Operations disclosure. We may take advantage of these exemptions until we are no longer an “emerging growth company.”

In addition, under the JOBS Act, “emerging growth companies” can delay adopting new or revised accounting standards until such time as those standards apply to private companies. We intend to avail ourselves of this exemption from new or revised accounting standards. Accordingly, we will not be subject to the same new or revised accounting standards as other public companies that are not “emerging growth companies.”

We will remain an “emerging growth company” until the earliest to occur of: (i) the last day of the fiscal year in which we have more than \$1.07 billion in annual revenue; (ii) the date we qualify as a “large accelerated filer,” with at least \$700 million of equity securities held by non-affiliates; (iii) the date on which we have issued, in any three-year period, more than \$1.0 billion in non-convertible debt securities; and (iv) the last day of the fiscal year ending after the fifth anniversary of the completion of this offering.

For certain risks related to our status as an “emerging growth company,” see the section titled “Risk Factors — Risks Related to Our Business and Industry — We are an ‘emerging growth company,’ and the

reduced disclosure requirements applicable to ‘emerging growth companies’ may make our Class B common stock less attractive to investors.”

### **Controlled Company Status**

We will be a “controlled company” within the meaning of the Nasdaq Listing Rules and its corporate governance requirements. Under these rules, a company for which more than 50% of the voting power for the election of directors is held by an individual, group, or another company is a “controlled company” and may elect not to comply with certain of the Nasdaq Listing Rules’ corporate governance requirements, including: (i) the requirement that a majority of our board of directors consist of “independent directors” as defined under the Nasdaq Listing Rules; (ii) the requirement that we have a compensation committee that is composed entirely of independent directors; and (iii) the requirement that we have a nominating and corporate governance committee that is composed entirely of independent directors. We intend to use these exemptions upon our listing. As a result, we will not have a majority of independent directors on our board of directors. Additionally, upon completion of this offering, we do not intend to have a compensation committee, nor do we intend to have a nominating and corporate governance committee or an independent nominating function. Instead, our full board of directors will be directly responsible for reviewing and approving compensation and benefit arrangements for our executive officers and directors, as well as for nominating members of our board. Accordingly, in the future our stockholders may not have the same protections afforded to stockholders of companies that are subject to all of the Nasdaq Listing Rules’ corporate governance requirements.

The following table presents the economic interests and combined voting power in Bentley Systems held by (i) the Bentleys and certain of their family members, trusts or other permitted transferees, as well as all other holders of our Class A common stock in respect of such shares of Class A common stock, who collectively are acting as a group (the “Bentley Control Group”), (ii) the Bentleys, certain other family members and trusts and other entities controlled by or primarily for the benefit of the Bentleys and their families (the “Bentley Family”), (iii) colleagues and other existing stockholders, and (iv) public stockholders, each upon the completion of this offering:

	Shares of Class A Common Stock	Shares of Class B Common Stock	Total Economic Interests		Combined Voting Power	
			Shares	%	Votes	%
Bentley Control Group	11,601,757	58,831,619	70,433,376	26.9%	395,282,572	67.4%
Bentley Family	11,263,492	163,415,356	174,678,848	66.8%	490,056,624	83.6%
Colleagues and other existing stockholders <sup>(1)</sup>	—	75,679,426	75,679,426	28.9%	75,679,426	12.9%
Public stockholders	—	10,750,000	10,750,000	4.1%	10,750,000	1.8%

(1) Excludes any shares that vote with the Bentley Control Group.

Upon the completion of this offering, the holders of our Class A common stock will be entitled to 29 votes per share, provided, however, that at any such time, and thereafter, as none of Barry J. Bentley, Gregory S. Bentley, Keith A. Bentley or Raymond B. Bentley is an executive officer or director of the Company, the holders of our Class A common stock will be entitled to 11 votes per share. All of our Class A common stock also will automatically convert into shares of our Class B common stock upon the affirmative vote of at least 90% of the then outstanding shares of Class A common stock or such time that the Bentley Family, collectively, directly or indirectly, own less than 20% of our issued and outstanding Class B common stock on a fully diluted basis (assuming the conversion of all issued and outstanding Class A common stock). Upon the completion of this offering, holders of our Class B common stock, which is the class of common stock that the selling stockholders are selling pursuant to this prospectus and is the only class that will be publicly traded and listed, will be entitled to one vote per share. See the section titled “Description of Capital Stock — Common Stock — Voting Rights” for additional information.



<b>THE OFFERING</b>	
Issuer	Bentley Systems, Incorporated
Class B common stock offered by the selling stockholders	10,750,000 shares (12,360,991 shares in the event the underwriters exercise their option to purchase additional shares in full)
Common stock to be outstanding after this offering:	
Class A common stock	11,601,757 shares
Class B common stock	249,632,970 shares
Total shares of common stock to be outstanding after this offering	261,234,727 shares
Voting rights	<p>Each share of our Class A common stock will be entitled to 29 votes per share and is convertible into one share of our Class B common stock at any time at a holder's option and automatically upon certain transfers, provided, however, that at any such time, and thereafter, as none of Barry J. Bentley, Gregory S. Bentley, Keith A. Bentley or Raymond B. Bentley is an executive officer or director of the Company, the holders of our Class A common stock will be entitled to 11 votes per share. All of our Class A common stock also will automatically convert into shares of our Class B common stock upon the affirmative vote of at least 90% of the then outstanding shares of Class A common stock or such time that the Bentley Family, collectively, directly or indirectly, own less than 20% of our issued and outstanding Class B common stock on a fully-diluted basis (assuming the conversion of all issued and outstanding Class A common stock). Each share of our Class B common stock will be entitled to one vote per share and is not convertible into any other shares of our capital stock. Holders of our Class A common stock and Class B common stock will generally vote together as a single class, unless otherwise required by our amended and restated certificate of incorporation or law.</p> <p>The shares of our Class A common stock outstanding after this offering will represent approximately 4.4% of the total number of shares of our Class A and Class B common stock outstanding after this offering and 57.4% of the combined voting power of our Class A and Class B common stock, and the Bentley Control Group and the Bentley Family will hold or have the ability to control approximately 67.4% and 83.6%, respectively, of the voting power of our outstanding capital stock. The Bentley Control Group will have the ability to control the outcome of matters submitted to our stockholders for approval, including the election of our directors and the approval of any change in control transactions. See the sections titled "Principal and Selling Stockholders" and "Description of Capital Stock" for additional information.</p> <p>See the section titled "— Controlled Company Status" above for information regarding ownership interests and voting power of our common stock.</p>

Use of proceeds	The selling stockholders will receive all of the proceeds from the sale of shares of our Class B common stock in this offering. We will not receive any proceeds from the sale of shares by the selling stockholders. The selling stockholders will not be responsible for any offering expenses.
Indication of interest	One or more funds affiliated with Capital Research Global Investors have indicated an interest in purchasing up to an aggregate of \$40 million in shares of our Class B common stock being offered by the selling stockholders in this offering at the initial public offering price. As this indication of interest is not a binding agreement or commitment to purchase, one or more funds affiliated with Capital Research Global Investors may determine to purchase more, fewer or no shares in this offering or the underwriters may determine to sell more, fewer or no shares to one or more funds affiliated with Capital Research Global Investors. The underwriters will receive the same discount from any shares of Class B common stock purchased by one or more funds affiliated with Capital Research Global Investors as they will from any other shares of Class B common stock sold to the public in this offering.
Risk factors	Investing in our Class B common stock involves risk. See the section titled “Risk Factors” in this prospectus for a discussion of the factors you should carefully consider before deciding to invest in our Class B common stock.
NASDAQ symbol	“BSY”
<p>The number of shares of our Class A and Class B common stock to be outstanding after this offering is based upon 11,601,757 shares of Class A common stock and 247,607,598 shares of Class B common stock outstanding as of June 30, 2020, plus:</p>	
<ul style="list-style-type: none"> <li>• 994,912 total shares of restricted Class B common stock and restricted stock units issued in July 2020 that will vest automatically upon the consummation of this offering, reduced by 32,238 of such restricted stock units that will be settled in cash;</li> <li>• 1,025,461 shares of Class B common stock being sold in this offering following the exercise of stock options for such shares at a weighted average exercise price of \$4.46 per share of Class B common stock, after giving effect to a \$1.50 reduction of the exercise price of all outstanding options as a result of the Special Dividend; and</li> <li>• 37,237 vested shares of restricted Class B common stock and restricted stock units issued in July 2020.</li> </ul>	
<p>The number of shares of our Class A and Class B common stock to be outstanding after this offering excludes:</p>	
<ul style="list-style-type: none"> <li>• 13,604,723 shares of Class B common stock issuable upon exercise of stock options outstanding as of the date of this prospectus that are not being sold in this offering, at a weighted average exercise price of \$4.85 per share of Class B common stock after giving effect to a \$1.50 reduction of the exercise price of all outstanding options as a result of the Special Dividend;</li> <li>• 45,151 shares of Class B common stock issuable upon the settlement of fully-vested restricted stock units outstanding as of June 30, 2020;</li> <li>• 900,000 shares of Class B common stock issuable upon exercise of stock options outstanding as of the date of this prospectus that are not being sold in this offering and were granted in connection with an acquisition, with an exercise price of \$6.81 per share and a maximum intrinsic value of \$8.88 per share;</li> </ul>	

- 1,311,447 shares of unvested restricted Class B common stock and restricted stock units outstanding as of the date of this prospectus that will not vest upon consummation of this offering;
- 27,941,520 shares of Class B common stock held by colleagues and directors as phantom shares under our nonqualified deferred compensation plans as of June 30, 2020, increased by 2,764,048 shares of Class B common stock as a result of the reinvestment of dividends since such date in accordance with such plans;
- 25,000,000 shares of Class B common stock reserved for issuance under our 2020 Incentive Award Plan (as defined herein); and
- 25,000,000 shares of Class B common stock reserved for issuance under our Global ESPP (as defined herein).

Except as otherwise indicated, all information in this prospectus assumes:

- no exercise of the underwriters' option to purchase additional shares; and
- the filing of our amended and restated certificate of incorporation and the effectiveness of our amended and restated by-laws, each of which will occur immediately prior to the completion of this offering, which we refer to in this prospectus as the "Charter Amendments."

### SUMMARY CONSOLIDATED FINANCIAL DATA

The following tables set forth summary consolidated financial data. The summary consolidated statement of operations data for the years ended December 31, 2018 and 2019 have been derived from our audited consolidated financial statements included elsewhere in this prospectus. The summary consolidated statement of operations data for the year ended December 31, 2017 has been derived from our audited consolidated financial statements not included in this prospectus, which were audited in accordance with the auditing standards of the American Institute of Certified Public Accountants rather than the auditing standards of the Public Company Accounting Oversight Board. The consolidated statements of operations data for the six months ended June 30, 2019 and 2020 and the consolidated balance sheet data as of June 30, 2020 have been derived from our unaudited consolidated financial statements included elsewhere in this prospectus. The unaudited consolidated financial statements include all adjustments, consisting of normal recurring accruals, that we consider necessary for a fair presentation of the financial position and the results of operations for these periods. You should read this summary consolidated financial data in conjunction with the sections titled “Selected Consolidated Financial Data” and “Management’s Discussion and Analysis of Financial Condition and Results of Operations” and our consolidated financial statements and related notes included elsewhere in this prospectus. Our historical results are not necessarily indicative of the results to be expected in the future, and our results of operations for the six months ended June 30, 2020 are not necessarily indicative of the results that may be expected for the entire year ending December 31, 2020 or any other period.

All amounts presented in this summary consolidated financial data, except share and per share amounts, are presented in thousands. Additionally, many of the amounts and percentages have been rounded for convenience of presentation.

#### Consolidated Statements of Operations Data:

	Year Ended December 31,				Six Months Ended June 30,	
	2017	2018	2019		2019	2020
	Topic 605		Topic 605 <sup>(1)</sup>	Topic 606	Topic 606	Topic 606
<b>Revenues:</b>						
Subscriptions	\$ 501,098	\$ 557,421	\$ 613,925	\$ 608,300	\$ 290,147	\$ 327,837
Perpetual licenses	61,661	61,065	52,519	59,693	24,468	23,193
Subscriptions and licenses	562,759	618,486	666,444	667,993	314,615	351,030
Services	66,164	73,224	68,405	68,661	32,529	27,950
Total revenues	628,923	691,710	734,849	736,654	347,144	378,980
<b>Cost of revenues:</b>						
Cost of subscriptions and licenses	53,662	55,113	71,439	71,578	30,831	43,128
Cost of services	66,928	76,211	72,572	72,572	38,367	30,836
Total cost of revenues	120,590	131,324	144,011	144,150	69,198	73,964
Gross profit	508,333	560,386	590,838	592,504	277,946	305,016
<b>Operating expenses:</b>						
Research and development	151,194	175,032	183,552	183,552	91,861	89,353
Selling and marketing	139,259	160,635	155,274	155,294	75,168	65,727
General and administrative	87,467	89,328	97,580	97,580	46,307	52,269
Amortization of purchased intangibles	9,014	14,000	14,213	14,213	6,852	7,115
Total operating expenses	386,934	438,995	450,619	450,639	220,188	214,464
Income from operations	121,399	121,391	140,219	141,865	57,758	90,552
Interest expense, net	(10,320)	(8,765)	(8,199)	(8,199)	(4,474)	(2,516)
Other income (expense), net	(5,773)	236	(5,557)	(5,557)	(1,747)	(6,985)
Income before income taxes	105,306	112,862	126,463	128,109	51,537	81,051
Provision for income taxes	46,141	(29,250)	21,762	23,738	5,119	11,440

	Year Ended December 31,			Six Months Ended June 30,		
	2017	2018	2019		2019	2020
	Topic 605	Topic 605 <sup>(1)</sup>	Topic 606	Topic 606	Topic 606	
Equity in loss of joint venture, net of tax	—	—	1,275	1,275	—	866
Net income	\$59,165	142,112	103,426	103,096	46,418	68,745
Less: Net income attributable to participating securities		(4)	(8)	(8)	(12)	—
Net income per share attributable to Class A and Class B common shares	\$ 142,108	\$ 103,418	\$ 103,088	\$ 46,406	\$ 68,745	
Net income per share:						
Basic	\$ 0.50	\$ 0.36	\$ 0.36	\$ 0.16	\$ 0.24	
Diluted	\$ 0.49	\$ 0.35	\$ 0.35	\$ 0.16	\$ 0.23	
Weighted average shares outstanding, basic	285,805,096	284,625,642	284,625,642	285,529,476	286,068,766	
Weighted average shares outstanding, diluted	292,624,496	293,796,707	293,796,707	293,633,255	295,595,234	

- (1) The Topic 605 amounts presented for the year ended December 31, 2019 give effect to revenue adjustments as if the adoption of Topic 606 had not occurred on January 1, 2019. For a reconciliation of the impact of adopting Topic 606 on our audited consolidated financial statements for the year ended December 31, 2019, see Note 2 to our consolidated financial statements included elsewhere in this prospectus.

#### Revenue Comparison — Topic 605 versus Topic 606:

On January 1, 2019, we adopted ASU No. 2014-09, *Revenue from Contracts with Customers*, and related amendments (“Topic 606”), which supersedes substantially all existing revenue recognition guidance under accounting principles generally accepted in the United States (“U.S. GAAP”). We adopted Topic 606 using the modified retrospective method, under which the cumulative effect of initially applying Topic 606 was recorded as a reduction to the opening balance of *Accumulated deficit* of \$125,464 (\$101,489, net of tax) as of January 1, 2019. We applied the standard only to contracts that were not completed as of the date of initial application. The comparative information in our consolidated financial statements included elsewhere in this prospectus continues to be reported in accordance with the guidance provided by Accounting Standards Codification (“ASC”) 985-605, *Software-Revenue Recognition* and Topic 605-25, *Revenue Recognition, Multiple-Element Arrangements*. We refer to ASC 985-605 and Topic 605-25 collectively as “Topic 605.”

The below table presents a comparison of our revenues as recognized under Topic 605 and Topic 606. We believe that an understanding of the impact of the revenue recognition guidance under Topic 606 on our revenues and revenue trends is useful in evaluating our operating performance.

	Year Ended December 31,		
	2017	2018	2019
Topic 605: <sup>(1)</sup>			
Subscriptions	\$501,098	\$557,421	\$613,925
Perpetual licenses	61,661	61,065	52,519
Services	66,164	73,224	68,405
Total revenues	\$628,923	\$691,710	\$734,849
Topic 606: <sup>(2)</sup>			
Subscriptions	\$505,720	\$560,485	\$608,300
Perpetual licenses	49,983	57,353	59,693
Services	66,164	73,224	68,661
Total revenues	\$621,867	\$691,062	\$736,654

- (1) The Topic 605 amounts presented for the year ended December 31, 2019 give effect to revenue adjustments as if the adoption of Topic 606 had not occurred on January 1, 2019. For a reconciliation of the impact of adopting Topic 606 on our audited consolidated financial statements for the year ended December 31, 2019, see Note 2 to our consolidated financial statements included elsewhere in this prospectus.
- (2) The Topic 606 unaudited amounts presented for the years ended December 31, 2017 and 2018 give effect to revenue adjustments as if the adoption of Topic 606 had occurred as of January 1, 2017 rather than January 1, 2019. For a reconciliation of the impact of adopting Topic 606 as if it had occurred as of January 1, 2017 on our audited consolidated statements of operations data for the years ended December 31, 2017 and 2018, see the section titled “Selected Consolidated Financial Data — Non-GAAP Financial Measures.”

**Key Business Metrics:**

We regularly review the following key metrics to evaluate our business, measure our performance, identify trends in our business, prepare financial projections, and make strategic decisions.

	Year Ended December 31,			Twelve Months Ended June 30,	
	2017	2018	2019	2019	2020
Last twelve-months recurring revenues (Topic 606)	\$521,923	\$586,466	\$631,097	\$606,411	\$665,659
Last twelve-months recurring revenues (Topic 605)	\$523,502	\$582,402	\$636,899	\$604,043	\$670,825
<b>Constant Currency:</b>					
Annualized recurring revenues (“ARR”) growth rate	9%	10%	12%	11%	11%
Account retention rate	98%	98%	98%	98%	98%
Recurring revenues dollar-based net retention rate	105%	107%	108%	106%	110%

**Last twelve-months recurring revenues.** Last twelve-months recurring revenues is calculated as recurring revenues recognized over the preceding twelve-month period. We define recurring revenues as subscriptions revenues that recur monthly, quarterly, or annually with specific or automatic renewal clauses and professional services revenues in which the underlying contract is based on a fixed fee and contains automatic annual renewal provisions.

Last twelve-months recurring revenues is presented using revenues recognized pursuant to Topic 606 as well as Topic 605 for all periods in order to enhance comparability during our transition to Topic 606. The Topic 606 unaudited amounts presented for the years ended December 31, 2017 and 2018 give effect to revenue adjustments as if the adoption of Topic 606 had occurred as of January 1, 2017 rather than January 1, 2019. For a reconciliation of the impact of adopting Topic 606 as if it had occurred as of January 1, 2017 on our audited consolidated statements of operations data for the years ended December 31, 2017 and 2018, see the section titled “Selected Consolidated Financial Data — Non-GAAP Financial Measures.”

On an annual and trailing twelve-month basis, we expect our recurring revenues recognized under Topic 606 to be comparable to such revenues recognized under Topic 605. This expectation is attributable to the annual, recurring nature of our subscription agreements. However, the conversion of our existing subscription users to consumption-based offerings with consumption measurement durations of less than one year, such as our E365 program, as well as the term start date of new annual term license subscriptions, will introduce some volatility between annual and trailing twelve-month periods and impact period over period comparability. Specifically, in 2019, the conversion of existing ELS subscriptions to consumption-based E365 subscriptions resulted in a reduction of Topic 606 Enterprise subscriptions revenues of \$11,248 when compared to Topic 605. This impact was partly offset by higher annual term license subscriptions

revenues under Topic 606 of \$5,714 due to the upfront recognition of license revenues of new subscriptions. See the section titled “Management’s Discussion and Analysis of Financial Condition and Results of Operations — Key Factors Impacting Comparability and Performance.”

We believe that last twelve-months recurring revenues is an important indicator of our performance during the immediately preceding twelve-month time period. We believe that we will continue to experience favorable growth in recurring revenues due to our strong account retention and recurring revenues dollar-based net retention rates as well as the addition of new accounts with recurring revenues. The last twelve-months recurring revenues under Topic 606 for the periods ended December 31, 2018, December 31, 2019, and June 30, 2020 compared to the last twelve-months of the preceding twelve-month period increased by \$64,543 (or \$59,900 under Topic 605), \$44,631 (or \$53,497 under Topic 605), and \$59,248 (or \$66,782 under Topic 605), respectively. These increases were primarily due to growth in ARR during the prior and current periods, which is primarily the result of consistent performance in our account retention rate and in our recurring revenues dollar-based net retention rate, as well as additional recurring revenues resulting from new accounts and acquisitions. For the twelve months ended December 31, 2019, 86% of our total revenues under Topic 606 (or 87% under Topic 605) were recurring revenues. For the twelve months ended June 30, 2020, 87% of our revenues were recurring revenues. Prospectively, we expect that this percentage is likely to remain consistent or modestly increase as we continue to target shifting episodic professional services revenues to subscriptions classified as recurring revenues.

**Constant currency metrics.** In reporting period-over-period results, we calculate the effects of foreign currency fluctuations and constant currency information by translating current period results using prior period average foreign currency exchange rates. Our definition of constant currency may differ from other companies reporting similarly named measures, and these constant currency performance measures should be viewed in addition to, and not as a substitute for, our operating performance measures calculated in accordance with U.S. GAAP.

**ARR growth rate.** Our ARR growth rate is the growth rate of our ARR, measured on a constant currency basis. Our ARR is defined as the sum of the annualized value of our portfolio of contracts that produce recurring revenue as of the last day of the reporting period, and the annualized value of the last three months of recognized revenues for our contractually recurring consumption-based software subscriptions with consumption measurement durations of less than one year. We believe that the last three months of recognized revenues, on an annualized basis, for our recurring software subscriptions with consumption measurement period durations of less than one year is a reasonable estimate of the annual revenues, given our consistently high retention rate and stability of usage under such subscriptions. ARR resulting from the annualization of recurring contracts with consumption measurement durations of less than one year, as a percentage of total ARR was 9%, 15%, and 25% as of December 31, 2017, 2018, and 2019, respectively, and 18% and 29% as of June 30, 2019 and 2020, respectively. Within our consumption-measured ARR, the successful uptake of our new E365 subscription offering has introduced daily consumption-measured ARR, representing 16% of total ARR as of June 30, 2020.

ARR is inclusive of the ARR of acquired companies as of the date they are acquired. We believe that ARR and ARR growth are important metrics indicating the scale and growth of our business. Furthermore, we believe ARR, considered in connection with our account retention rate and our recurring revenues dollar-based net retention rate, is a leading indicator of revenue growth. Our ARR as of June 30, 2020 was \$697,682, calculated using the spot foreign exchange rates as of June 30, 2020.

There was no impact to our ARR growth rate from acquisitions for the year ended December 31, 2017. Our ARR growth rate was favorably impacted from acquisitions by 3% and 1% for the years ended December 31, 2018 and 2019, respectively, and by 1% and 2% for the twelve months ended June 30, 2019 and 2020, respectively.

**Account retention rate.** Our account retention rate for any given twelve-month period is calculated using the average currency exchange rates for the prior period, as follows: the prior period recurring revenues from all accounts with recurring revenues in the current and prior period, divided by total recurring revenues from all accounts during the prior period. The account retention rate is calculated using revenues recognized pursuant to Topic 605 for all periods in order to enhance comparability during our transition to Topic 606 as we do not have all information available to us necessary to present account retention rate

pursuant to Topic 606 for any period prior to January 1, 2019. Our account retention rate is an important indicator that provides insight into the long-term value of our account relationships and our ability to retain our account base. We believe that our consistent and high account retention rates illustrate our ability to retain and cultivate long-term relationships with our accounts.

*Recurring revenues dollar-based net retention rate.* Our recurring revenues dollar-based net retention rate is calculated using the average exchange rates for the prior period, as follows: the recurring revenues for the current period, including any growth or reductions from accounts with recurring revenue in the prior period (“existing accounts”), but excluding recurring revenues from any new accounts added during the current period, divided by the total recurring revenues from all accounts during the prior period. A period is defined as any trailing twelve months. The recurring revenues dollar-based net retention rate is calculated using revenues recognized pursuant to Topic 605 for all periods in order to enhance comparability during our transition to Topic 606 as we do not have all information available to us necessary to present recurring revenues dollar-based net retention rate pursuant to Topic 606 for any period prior to January 1, 2019. We believe our recurring revenues dollar-based net retention rate is a key indicator of our success in growing our revenues within our existing accounts. Given that for the twelve months ended December 31, 2019 recurring revenues represented 86% of our total revenues under Topic 606, this metric helps explain our revenue performance as primarily growth into existing accounts. We believe that our consistent and high recurring revenues dollar-based net retention rate illustrates our ability to consistently retain accounts and grow them.

As discussed above, we expect annual and trailing twelve-month recurring revenues recognized under Topic 606 to be comparable to such revenues recognized under Topic 605 due to the annual, recurring nature of our subscription agreements. We, therefore, also expect that our account retention rate and our recurring revenue dollar-based net retention rate under Topic 606 will be comparable to such metrics under Topic 605. However, under Topic 606, the conversion of our existing subscription users to consumption-based offerings with consumption measurement durations of less than one year, such as our E365 program, as well as the term start date of new subscriptions, will introduce some volatility between annual, and trailing twelve-month periods and impact period over period comparability. See the section titled “Key Factors Impacting Comparability and Performance.”

Our calculation of these metrics may not be comparable to other companies with similarly-titled metrics.

For additional information about our key metrics, see the sections titled “Selected Consolidated Financial Data — Key Business Metrics” and “Management’s Discussion and Analysis of Financial Condition and Results of Operations — Key Business Metrics.”

#### **Non-GAAP Financial Measures:**

In addition to our results determined in accordance with U.S. GAAP, we believe the below non-GAAP measures are useful in evaluating our operating performance. We use the below non-GAAP financial information, collectively, to evaluate our ongoing operations and for internal planning and forecasting purposes.

	Year Ended December 31,		
	2017	2018	2019
Topic 605: <sup>(1)</sup>			
Adjusted EBITDA	\$160,886	\$171,768	\$186,598
Adjusted Net Income	\$115,389	\$132,246	\$135,471
Topic 606: <sup>(2)</sup>			
Adjusted EBITDA	\$153,830	\$171,120	\$188,129
Adjusted Net Income	\$109,398	\$131,697	\$135,049

(1) The Topic 605 amounts presented for the year ended December 31, 2019 give effect to revenue adjustments as if the adoption of Topic 606 had not occurred on January 1, 2019. For a reconciliation



of the impact of adopting Topic 606 on our audited consolidated financial statements for the year ended December 31, 2019, see Note 2 to our consolidated financial statements included elsewhere in this prospectus.

- (2) The Topic 606 unaudited amounts presented for the years ended December 31, 2017 and 2018 give effect to revenue adjustments as if the adoption of Topic 606 had occurred as of January 1, 2017 rather than January 1, 2019. For a reconciliation of the impact of adopting Topic 606 as if it had occurred as of January 1, 2017 on our audited consolidated statements of operations data for the years ended December 31, 2017 and 2018, see the section titled “Selected Consolidated Financial Data — Non-GAAP Financial Measures.”

	<u>Six Months Ended June 30,</u>	
	<u>2019</u>	<u>2020</u>
<b>Topic 606:</b>		
Adjusted EBITDA	\$79,384	\$115,506
Adjusted Net Income	\$59,978	\$ 89,203

For additional information, including the limitations of using non-GAAP financial measures, and reconciliations of the non-GAAP financial measures to the most directly comparable financial measures stated in accordance with U.S. GAAP, see the section titled “Selected Consolidated Financial Data — Non-GAAP Financial Measures.”

#### **Consolidated Balance Sheet Data:**

The following table presents summary consolidated balance sheet data as of June 30, 2020 on:

- an actual basis;
- a pro forma basis to give effect to (i) the payment of the Special Dividend and the funding of such Special Dividend with borrowings under the New Term Loan and under the revolving facility under the Credit Facility and (ii) the accrual of the Special Dividend on 2,204,572 shares of outstanding restricted stock and restricted stock units; and
- a pro forma as adjusted basis to give effect to the Special Dividend and the funding of such Special Dividend as described in the immediately preceding bullet and to further (i) give effect to (A) 994,912 total shares of restricted Class B common stock and restricted stock units issued in July 2020 that will vest automatically upon the consummation of this offering, reduced by 32,238 of such restricted stock units that will be settled in cash, (B) approximately \$11.7 million in additional stock-based compensation expense, net of tax, in connection with such July 2020 grant (excluding restricted stock units that will settle in cash), (C) 1,025,461 shares of Class B common stock to be sold in this offering following the exercise of stock options for such shares, at a weighted average exercise price of \$4.46 per share, after giving effect to a \$1.50 reduction of the exercise price of all outstanding options as a result of the Special Dividend, as if such exercise had occurred on June 30, 2020 and (D) approximately \$0.5 million in additional stock-based compensation expense, net of tax, in connection with 37,237 vested shares of restricted Class B common stock and restricted stock units issued in July 2020, (ii) reflect expenses of \$20.8 million, net of tax, in connection with this offering by the Company, including those paid on behalf of the selling stockholders and the underwriting discounts and commissions based on the initial public offering price of the Class B common stock of \$22.00 per share and (iii) reflect the payment in cash of the Special Dividend on 994,912 shares of outstanding restricted stock and restricted stock units that vest automatically upon the consummation of this offering, using additional borrowings under the revolving facility under the Credit Facility.

	June 30, 2020		
	Actual	Pro forma	Pro forma as adjusted
Cash and cash equivalents <sup>(1)</sup>	\$ 125,516	\$ 125,516	\$ 109,788
Working capital, excluding deferred revenues	104,275	102,831	89,931
<b>Total assets</b>	<b>1,059,169</b>	<b>1,059,169</b>	<b>1,042,600</b>
Deferred revenues, current and long-term	186,456	186,456	186,456
<b>Total debt</b>	<b>207,000</b>	<b>596,583</b>	<b>598,075</b>
Total stockholders' equity (deficit) <sup>(1)</sup>	379,744	(13,028)	(25,931)

(1) Pro forma as adjusted amount does not include \$709 of stock-based compensation expense for 32,238 restricted stock units that will vest automatically upon the consummation of this offering and be settled in cash at the initial public offering price of \$22.00 per share.

## RISK FACTORS

*Investing in our Class B common stock involves a high degree of risk. You should carefully consider the risks and uncertainties described below, together with all of the other information in this prospectus, including the consolidated financial statements and the related notes and the section titled “Management’s Discussion and Analysis of Financial Condition and Results of Operations,” before deciding whether to invest in shares of our Class B common stock. The risks and uncertainties described below are not the only ones we face. Additional risks and uncertainties that we are unaware of, or that we currently believe are not material, may also become important factors that adversely affect our business. If any of the following risks, or other risks and uncertainties that are not yet identified or that we currently think are immaterial, actually occur, our business, financial condition, results of operations and future prospects could be materially and adversely affected. In that event, the market price of our Class B common stock could decline, and you could lose part or all of your investment.*

### Risks Related to Our Business and Industry

***Demand for our software solutions is subject to volatility in our accounts’ underlying businesses, which includes infrastructure projects that typically have long timelines.***

Our sales are based significantly on accounts’ demand for software solutions in the following infrastructure sectors: (i) public works/utilities; (ii) industrial/resources; and (iii) commercial/facilities. Although these sectors are typically countercyclical to one another in nature, each periodically experiences economic declines and may be exacerbated by other economic factors. If participants in any of these sectors reduce spending or allocate future funding in a manner that results in fewer infrastructure improvement or expansion projects, then our accounts’ underlying business may be impacted and demand for our software solutions may decrease or our rate of contract renewals may decrease. A prolonged decrease in such spending may harm our results of operations. Our accounts may request discounts or extended payment terms on new arrangements or seek to extend payment terms on existing arrangements due to lower levels of infrastructure spending or for other reasons, all of which may reduce revenue. We may not be able to adjust our operating expenses to offset such discounts or other arrangements because a substantial portion of our operating expenses is related to personnel, facilities and marketing programs. The level of personnel and related expenses may not be able to be adjusted quickly and is based, in significant part, on our expectations for future revenues and demand.

Infrastructure projects typically have long timelines and we may invest in building capacity based on expected demand for our software solutions that takes longer to develop than we expect or fails to develop at all. Additionally, government spending on infrastructure may decrease, which could decrease the demand for our software solutions and have a negative impact on our results of operations. We may not be successful in forecasting future demand levels and could fail to win business at the expected rates. If we underestimate the demand for our software solutions, we may be unable to fulfill the increased demand in a timely fashion or at all. If we overestimate the demand for our software solutions, we may incur additional expenses for which we would not have corresponding revenues, negatively impacting our results of operations.

***The majority of our revenues and an increasing percentage of our operations are attributable to operations outside the United States, and our results of operations therefore may be materially affected by the legal, regulatory, social, political, economic and other risks of foreign operations.***

Approximately 60%, 58% and 58% of our total revenues were from outside the United States in the years ended December 31, 2018 and 2019, and six months ended June 30, 2020, respectively. We anticipate that revenues from accounts outside the United States will continue to comprise a majority of our total revenues for the foreseeable future.

Our international revenues, including from emerging economies, are subject to general economic and political conditions in foreign markets and our revenues are impacted by the relative geographical and country mix of our revenues over time. These factors could adversely impact our international revenues and, consequently, our business. Our dependency on international revenues also makes us more exposed to global economic and political trends, which can negatively impact our financial results. Further, our operations outside the United States are subject to certain legal, regulatory, social, political, economic and other risks inherent in international business operations, including, without limitation:

- local product preference and product requirements;
- different consumer demand dynamics, which may make the products and services we offer less successful compared to the United States;
- more stringent regulations relating to privacy and data security and access to, or use of, commercial and personal information, such as the European Union’s General Data Protection Regulation (the “GDPR”), and the Cybersecurity Law of the People’s Republic of China;
- data privacy laws that require that account data be stored and processed in a designated territory or that certain transfers of account data outside of the country be notified to or registered with regulatory authorities;
- competition from local incumbents that understand the local market and may operate more effectively;
- trade protection measures, sanctions, quotas, embargoes, import and export licensing requirements, duties, tariffs or surcharges;
- changes in foreign regulatory requirements and tax laws;
- unexpected changes in foreign regulatory requirements;
- difficulty in establishing, staffing and managing non-U.S. operations;
- differing labor regulations where labor laws may be more advantageous to colleagues as compared to the United States, as well as increased labor costs;
- political and economic instability;
- fluctuating currency exchange rates, currency controls and inflation, recession or interest rate fluctuations;
- longer-term receivables than are typical in the United States and greater difficulty of collecting receivables in certain foreign jurisdictions;
- alleged or actual violations of anti-bribery and anti-corruption laws, rules and regulations in the foreign jurisdictions in which we do business;
- restrictions on the export of critical technology, software and services;
- complex tax and cash management issues;
- potentially adverse tax consequences, including the complexities of foreign value added tax systems, restrictions on the repatriation of earnings and changes in tax rates;
- the burdens of complying with a wide variety of foreign laws and different legal standards;
- longer sales and accounts receivable payment cycles in some countries;
- increased financial accounting and reporting burdens and complexities;
- terrorist attacks and security concerns in general;
- natural disasters and pandemics, including the ongoing COVID-19 pandemic;
- less rigorous or varied protection for intellectual property rights in some countries; and
- providing our solutions to accounts from different cultures, which may require us to adapt to sales practices, modify our solutions or products, and provide features necessary to effectively serve the local market.

The occurrence of any one of these risks could negatively affect our international business and, consequently, our business, financial condition and results of operations. Additionally, operating in international markets requires significant management attention and financial resources. We cannot be certain that the investment and additional resources required to operate in other countries will produce desired levels of revenue or profitability.

***Recent and potential tariffs imposed by the U.S. government or a global trade war could increase the cost of our products and services and the cost of conducting our business, which could harm our business, financial condition and results of operations.***

Recent and potential tariffs imposed by the U.S. government or a global trade war could increase the cost of our products and services and the cost of conducting our business, which could harm our business, financial condition and results of operations. The U.S. government has threatened substantial changes to trade agreements and has raised the possibility of imposing significant increases on tariffs on goods imported into the United States, particularly from China. The imposition of additional tariffs by the United States could result in the adoption of tariffs by other countries, leading to a global trade war. In addition, certain of these risks may be heightened as a result of changing political climates, which may also be exacerbated as a result of the COVID-19 pandemic. For example, throughout 2018 and 2019, the United States and China have been levying tariffs on their respective imports. Such tariffs could have a significant impact on our business and the business of our accounts. While we may attempt to renegotiate prices with suppliers or diversify our supply chain in response to tariffs, such efforts may not yield immediate results or may be ineffective. We might also consider increasing prices to the end consumer; however, this could reduce the competitiveness of our products and services and adversely affect revenue. If we fail to manage these dynamics successfully, our gross margins and profitability could be adversely affected.

In addition, increases in the extent to which global trade is limited by tariffs or other trade barriers could negatively affect decisions to invest in infrastructure projects due to decreasing confidence in future profitability of such projects. Such resulting decreases in infrastructure spending could negatively affect demand for our software solutions, which could harm our business, financial condition, and results of operations.

***Global economic conditions may negatively impact our business, financial condition, and results of operations.***

Our operations and performance depend significantly on foreign and domestic economic conditions. Uncertainty regarding economic conditions may negatively impact us as accounts defer spending or postpone infrastructure projects in response to tighter credit, higher unemployment, financial market volatility, government austerity programs, negative financial news, escalations of hostilities or the threat of hostilities, pandemics, declining valuations of investments and other factors. In addition, certain of our accounts' budgets may be constrained and they may be unable to procure our solutions at the same level as in prior periods. Our accounts' ability to pay for our software solutions and services may also be impaired, which may lead to an increase in our allowance for doubtful accounts and write-offs of accounts receivable. Since we are exposed to the majority of major world markets, uncertainty in any significant market may negatively impact our performance and results, particularly with respect to our largest geographic accounts. Our accounts include government entities, including the U.S. government, and if spending cuts impede the ability of governments to purchase our products and services, our revenues could decline. In addition, a number of our accounts rely, directly and indirectly, on government spending. We are unable to predict economic conditions or the likelihood of additional economic uncertainty arising in any of our key markets. Changes in economic conditions could result in us not meeting our revenue growth objectives, and could harm our cash flows, business, financial condition and results of operations.

Geopolitical trends toward nationalism and protectionism and the weakening or dissolution of international trade pacts may increase the cost of, or otherwise interfere with, conducting our business. These trends have increased levels of political and economic unpredictability globally, and may increase the volatility of global financial markets; the impact of such developments on the global economy remains uncertain. Political instability or adverse political developments, including, without limitation, as a result of or in connection with the upcoming 2020 United States presidential election and trade relations between the United States in China, in any of the countries in which we do business could harm our business, financial condition and results of operations.

***Decreased investment by APAC, including China, may have a negative effect on our business.***

Approximately 19%, 20% and 19% of our revenues in the years ended December 31, 2018 and 2019 and six months ended June 30, 2020, respectively, relate to infrastructure projects in APAC, including China. We cannot assure you that spending in these countries on infrastructure projects will continue at

historical levels or increase in the future, or that demand for our software solutions in APAC in general will not be negatively affected by reductions in spending or other limitations.

***The ongoing global coronavirus outbreak could materially and adversely affect our business***

In March 2020, the World Health Organization declared a global pandemic related to the rapidly growing outbreak of the disease COVID-19, caused by a novel strain of coronavirus, SARS-CoV-2. The COVID-19 outbreak and certain preventative or protective actions that governments, businesses and individuals have taken in respect of COVID-19 have resulted in global business disruptions. The COVID-19 pandemic has adversely affected global economies, financial markets and the overall environment in which we do business, and the extent to which it may impact our future results of operations and overall financial performance remains uncertain. Our accounts' usage of our solutions slightly declined during the months of March and April when compared to levels from the same periods in 2019, and our revenue growth has also been modestly impacted, primarily due to lower growth of our non-recurring solutions including perpetual licenses and professional services engagements due to the COVID-19 pandemic. The duration and extent of the impact from the COVID-19 pandemic depends on future developments that cannot be accurately predicted at this time, such as the severity and transmission rate of the virus, the extent and effectiveness of containment actions and the impact of these and other factors on our colleagues, accounts, suppliers and partners. The COVID-19 pandemic may continue to materially affect the economies and financial markets in impacted countries and countries in which we operate, causing continued economic downturn that could decrease spending on infrastructure projects and adversely affect demand for our software solutions. Such impact on our business, operating results, cash flows and/or financial condition could be material. The COVID-19 pandemic may also have the effect of heightening other risks disclosed in these Risk Factors, such as, but not limited to, those related to supply chain interruptions and labor availability and cost.

***The sales cycle for some of our solutions can be long and unpredictable and requires considerable time and expense, which may cause our results of operations to fluctuate.***

The sales cycle for some of our solutions, from initial contact with a potential lead to contract execution and implementation, varies widely by brand and account, and can be lengthy. Some of our accounts undertake a significant evaluation process that frequently involves not only our solution, but also solutions of our competitors, which may result in extended sales cycles. Our sales efforts involve educating our accounts and prospective accounts about the use, technical capabilities and benefits of our solutions. We also put a significant amount of time into discussing with our accounts the value and importance of migrating to the latest versions of our software solutions. We have no assurance that the substantial time and money spent on our sales efforts will increase sales or cause existing accounts to migrate to the latest versions of our software solutions. Furthermore, our sales and marketing efforts in a given period may only result in sales in subsequent periods, or not at all. If we do not realize sales in the time period expected or at all, our business, financial condition, and results of operations could be adversely affected.

***If we do not keep pace with technological changes, and effectively market our new product solutions, our solutions may become less competitive and our business may suffer.***

We operate in an industry generally characterized by rapidly changing technology and frequent new software introductions, which can render existing software obsolete or unmarketable. A major factor in our future success will be our ability to anticipate technological changes and to develop and introduce, in a timely manner, enhancements to our existing software solutions, new software solutions and software solutions acquired in acquisitions to meet those changes. In particular, the software industry has undergone a transition from developing and selling perpetual licenses and on-premises products to cloud, mobile, and social applications. If we are unable to adapt our software solutions to the changing needs of our accounts and infrastructure engineers and to respond quickly to sector changes, our business, financial condition, results of operations, and cash flows could be harmed.

The introduction and marketing of new or enhanced software solutions require us to manage the transition from existing software to minimize disruption in account use and purchasing patterns. There can be no assurance that we will be successful in developing and marketing, on a timely basis, new software or enhancements, that our new software solutions will adequately address the changing needs of the marketplace

or that we will successfully manage the transition from existing software solutions. In addition, our future software solutions may require a higher level of sales and support expertise. Any inability of our sales team, including our channel partners, to obtain this expertise and to sell the new software offerings effectively could have an adverse impact on our sales in future periods. Any of these problems may result in the loss of or delay in account acceptance, decreased demand for or usage of our software solutions, damage to our reputation, or increased service and warranty costs, any of which could harm our business, financial condition, results of operations, and cash flows.

We must act quickly, continuously, and with vision, given the rapidly changing expectations and technology advancements inherent in the software industry, the extensive and complex efforts required to create useful and widely accepted products and the rapid evolution of cloud computing, mobile devices, new computing platforms, and other technologies. Although we have articulated a strategy that we believe will fulfill these challenges, if we fail to execute properly on that strategy or adapt that strategy as market conditions evolve, we may fail to meet our accounts' expectations, fail to compete with our competitors' products and technology, and lose the confidence of our channel partners and colleagues, which in turn could adversely affect our business and financial performance.

***Interruptions in the availability of server systems or communications with Internet, third-party hosting facilities or cloud-based services, or failure to maintain the security, confidentiality, accessibility, or integrity of data stored on such systems, could harm our business or impair the delivery of our managed services.***

A significant portion of our software development personnel, source code, and computer equipment is located at operating facilities outside the United States. We also depend on data maintained on servers running third-party enterprise resource planning, account relationship management, and other business operations systems. We further rely upon a variety of Internet service providers, third-party hosting facilities, and cloud computing platform providers, such as Microsoft Azure, as well as local service providers to support project teams and users in most regions and countries throughout the world, particularly with respect to our cloud service solutions. Failure to maintain the security, confidentiality, accessibility, or integrity of data stored on such systems could damage our reputation in the market and our relationships with our accounts, cause us to lose revenue or market share, increase our service costs, cause us to incur substantial costs, cause us to lose accounts, subject us to liability for damages and divert our resources from other tasks, any one of which could adversely affect our business, financial condition, results of operations, and prospects. Any damage to, or failure of, such systems, or communications to and between such systems, could result in interruptions in our operations, managed services and software development activities. Such interruptions may reduce our revenue, delay billing, cause us to issue credits or pay penalties, cause accounts to terminate their subscriptions or adversely affect our attrition rates and our ability to attract new accounts. Our business would also be harmed if our accounts and potential accounts believe our products or services are unreliable.

***If our security measures or those of our third-party cloud data hosts, cloud computing platform providers, or third-party service partners, are breached, and unauthorized access is obtained to an account's data, our data or our IT systems, our services may be perceived as not being secure, accounts may curtail or stop using our services, and we may incur significant legal and financial exposure and liabilities.***

As we digitize and use cloud and web-based technologies to leverage account data to deliver a more complete account experience, we are exposed to increased security risks and the potential for unauthorized access to, or improper use of, our and our accounts' information. Certain of our services involve the storage and transmission of accounts' proprietary information, and security breaches could expose us to a risk of loss of this information, litigation and possible liability. Although we devote resources to maintaining our security and integrity, we may not prevent security incidents.

The risk of a security breach or disruption, particularly through cyber attack or cyber intrusion, including by computer hackers, foreign governments and cyber terrorists, has increased as the number, intensity, and sophistication of attempted attacks and intrusions from around the world have increased. These threats include but are not limited to identity theft, unauthorized access, domain name system attacks, wireless network attacks, viruses and worms, advanced persistent threat, application centric attacks, peer-to-peer attacks, phishing, backdoor trojans, and distributed denial of service attacks. Any of the foregoing

could attack our accounts' data (including their employees' personal data), our data (including colleagues' personal data) or our IT systems. It is virtually impossible for us to entirely eliminate this risk. Like all software, our software is vulnerable to cyber attacks. The impact of cyber attacks could disrupt the proper functioning of our software solutions or services, cause errors in the output of our accounts' work, allow unauthorized access to sensitive, proprietary or confidential information of ours or our accounts, and other destructive outcomes.

Additionally, third parties may attempt to fraudulently induce colleagues or accounts into disclosing sensitive information such as user names, passwords or other information in order to gain access to our accounts' data, our data or our IT systems. Malicious third parties may also conduct attacks designed to temporarily deny accounts access to our services. Any security breach could result in a loss of confidence in the security of our products and services, damage our reputation, negatively impact our future sales, disrupt our business and lead to regulatory inquiry and legal liability.

***We are exposed to fluctuations in currency exchange rates that could negatively impact our financial results and cash flows.***

We sell our solutions in 172 countries, primarily through a direct sales force located throughout the world. Approximately 60%, 58% and 58% of our total revenues were from outside the United States in the years ended December 31, 2018 and 2019, and six months ended June 30, 2020, respectively. As we continue to expand our presence in international regions, the portion of our revenue, expenses, cash, accounts receivable and payment obligations denominated in foreign currencies continues to increase. Further, we anticipate that revenues from accounts outside of the United States will continue to comprise the majority of our total revenues for the foreseeable future.

Because of our international activities, we have revenue, expenses, cash, accounts receivable and payment obligations denominated in foreign currencies. In the years ended December 31, 2018 and 2019, and the six months ended June 30, 2020, 49%, 47% and 44%, respectively, of our total revenues were denominated in a currency other than the U.S. Dollar. As a result, we are subject to currency exchange risk. Our revenues and results of operations are adversely affected when the U.S. Dollar strengthens relative to other currencies and are positively affected when the U.S. Dollar weakens. As a result, changes in currency exchange rates will affect our financial position, results of operations and cash flows. In the event that there are economic declines in countries in which we conduct transactions, the resulting changes in currency exchange rates may affect our financial condition, results of operations, and cash flows. We are most impacted by movements in and among the Euro, British Pound, Australian Dollar, Canadian Dollar, and Chinese Yuan Renminbi. For example, the Chinese Yuan Renminbi has fluctuated against the U.S. Dollar, at times significantly and unpredictably, due to changes in foreign exchange for a wide variety of reasons, including actions instituted by China. Because of changes in trade between the United States and China and Renminbi internationalization, the China may in the future announce further changes to the exchange rate system, and we cannot assure you that the Renminbi will not appreciate or depreciate significantly in value against the U.S. Dollar in the future.

In addition, countries in which we operate may be classified as highly inflationary economies, requiring special accounting and financial reporting treatment for such operations, or such countries' currencies may be devalued, or both, which may harm our business, financial condition, and results of operations.

We cannot predict the impact of foreign currency fluctuations and we may not be successful in minimizing the risks of these fluctuations. In addition, the fluctuation and volatility of currencies, even when it increases our revenues or decreases our expenses, impacts our ability to accurately predict our future results and earnings.

***We face intense competition.***

We continue to experience competition across all markets for our software solutions and services. Our competitors include large, global, publicly-traded companies, small, specialty or geographically-focused firms and organizations who develop their own solutions internally. Some of our current and possible future competitors have greater financial, technical, sales, marketing and other resources than us, some specialize in developing niche software solutions and some have well-established relationships with our current and



potential accounts. There is no assurance that we will be able to continue to compete effectively. Parties among our current or future strategic alliances may diminish or sever technical, software development and marketing relationships with us for competitive purposes. These competitive pressures may result in decreased sales volumes, price reductions, and/or increased operating costs, and could result in lower revenues, margins, and net income.

***We may not be able to increase the number of new subscription-based accounts or cause existing accounts to renew their subscriptions, which could have a negative impact on our future revenues and results of operations.***

We may not be able to increase demand for our subscription-based services in line with our growth strategy. Our accounts are not obligated to renew their subscriptions for our offerings, and they may elect not to renew. We cannot assure renewal rates, or the mix of subscriptions renewals. Account renewal rates may decline or fluctuate due to a number of factors, including offering pricing, competitive offerings, account satisfaction, and reductions in account spending levels or account activity due to economic downturns or financial markets uncertainty. If our accounts do not renew their subscriptions or if they renew on less favorable terms, our revenues may decline, which could harm our business, financial condition, and results of operations.

***Our revenue recognition policy and other factors may create volatility in our financial results in any given period and make them difficult to predict.***

As described in Note 3 to our consolidated financial statements for the years ended December 31, 2018 and 2019 included elsewhere in this prospectus, we adopted ASC 606 effective January 1, 2019. The new revenue guidance significantly impacts our timing of subscriptions and perpetual licenses revenue. Under previous revenue guidance, we historically maintained stable recurring revenue from the sale of software subscriptions and perpetual licenses. Under ASC 606, perpetual licenses and the license component of applicable subscriptions are recognized up front. The maintenance portion of subscription contracts continues to be recognized over the contract term.

The adoption of the new revenue recognition guidance creates the likelihood for subscriptions and licenses revenue volatility to increase across quarterly periods, particularly as compared to our results under the previous revenue recognition standard. Annual and trailing twelve-months subscription revenues will be more consistent between periods, and as compared to our results under the previous revenue recognition standard, due to the annual, recurring nature of our subscription agreements. However, annual results are still subject to volatility due to the timing of renewals between periods, timing of new sales contracts, changes in contract term and length, changes in perpetual license sales, and conversion of existing subscription users to other commercial offerings, particularly consumption-based offerings with consumption measurement durations of less than one year.

***Our quarterly results of operations have fluctuated in the past and may fluctuate in the future, which could cause the price of our Class B common stock to decline or become volatile. These potential fluctuations can make our future results difficult to predict and cause our results of operations to fall below analyst or investor expectations.***

Our quarterly results of operations have fluctuated in the past and may fluctuate in the future as a result of a variety of factors, many of which are outside of our control. If our quarterly results of operations or guidance fall below the expectations of research analysts or investors, the price of our Class B common stock could decline substantially. The following factors, among others, could cause fluctuations in our quarterly results of operations:

- our success in selling our subscription and services offerings;
- our ability to attract new accounts and retain existing accounts, including in connection with consolidation activities among, or management changes at, our accounts;
- our ability to accurately forecast revenues and appropriately plan our expenses;
- our ability to introduce new features, including ensuring inter-operational ability with our existing solutions and with third-party software and devices;

- our receiving milestone payments in respect of the projects for which our software is providing solutions;
- the actions of our competitors, including consolidation within the industry, pricing changes or the introduction of new solutions;
- our ability to effectively manage our growth;
- our ability to successfully manage any future acquisitions of businesses, solutions or technologies;
- the timing and cost of developing or acquiring technologies or businesses;
- the timing, operating costs and capital expenditures related to the operation, maintenance and expansion of our business;
- service outages or security breaches and any related occurrences that could impact our reputation;
- the impact of worldwide economic, industry and market conditions, including disruptions in financial markets and the deterioration of the underlying economic conditions in some countries;
- trade protection measures, such as tariffs and duties, and import or export licensing requirements;
- fluctuations in currency exchange rates;
- changes in government regulation affecting our business; and
- costs associated with defending intellectual property infringement and other claims.

Our quarterly revenues and results of operations may vary in the future, and period-to-period comparisons of our results of operations may not be meaningful. Any one or more of the factors above may result in significant fluctuations in our quarterly results of operations. You should not rely on the results of one quarter as an indication of future performance.

The variability and unpredictability of our quarterly results of operations or other operating metrics could result in our failure to meet our expectations or those of analysts that cover us or investors with respect to revenues or other key metrics for a particular period. If we fail to meet or exceed such expectations for these or any other reasons, the market price of our Class B common stock could fall, and we could face costly lawsuits, including securities class action suits.

***Failure to protect our intellectual property rights could impair our ability to protect our proprietary technology and our brand.***

Our future success and competitive position depend in large part on our ability to protect our intellectual property and proprietary technologies. We rely on a combination of copyright, patent, trademark and trade secret laws, as well as confidentiality procedures and contractual restrictions, to secure and protect our intellectual property rights, all of which provide only limited protection and may not currently or in the future provide us with a competitive advantage. Patents or trademarks may not issue from any of our pending or future patent or trademark applications. Patents or trademarks that do issue from such applications may not give us the protection that we seek, and such patents or trademarks may be challenged, invalidated, or circumvented. Any patents or trademarks that may issue in the future from our pending or future patent and trademark applications may not provide sufficiently broad protection and may not be enforceable in actions against alleged infringers.

The steps we take may not be adequate to protect our technologies and intellectual property, our patent and trademark applications may not lead to issued patents or registered trademarks, others may develop or patent similar or superior technologies or solutions, and our patents, trademarks, and other intellectual property may be challenged, invalidated, designed around or circumvented by others. Furthermore, effective copyright, patent, trademark and trade secret protection may not be available in every country in which our solutions are available or where we do business.

The steps we have taken, and will take, may not prevent unauthorized use, reverse engineering, or misappropriation of our technologies and we may not be able to detect any of the foregoing. Others may independently develop technologies that infringe on our intellectual property rights. In addition, we cannot

control the use of our open source components, which could allow third parties to create products or solutions that compete with our offerings or that contain errors, defects or other performance problems that could hurt our reputation and reduce the adoption of our solutions in new and existing accounts. Defending and enforcing our intellectual property rights may result in litigation or other contentious actions, any such litigation may not be successful, and even if successful, such litigation can be costly and divert management attention and resources. Further, if we are unsuccessful in asserting our intellectual property rights, an adverse decision could place limitations on the scope of our rights. If our efforts to protect our technologies and intellectual property are inadequate, the value of these intangible assets may be diminished and competitors may be able to replicate our solutions and methods of operations. Any of these events could harm our business, financial condition, and results of operations.

Although copyright protection is available for works of authorship such as computer code, we primarily rely on trade secrets laws to protect our proprietary software code, and have chosen not to register copyrights for the code. Under the United States Copyright Act, copyrights must be registered before the copyright owner may bring an infringement suit in the United States, and if a copyright is not registered within three months of publication of the underlying work, there are limitations on the damages that the copyright owner may be awarded for infringement. Accordingly, because we have chosen not to register the copyrights in our software, the causes of action, remedies and damages available to us in an enforcement action may be limited.

***Consolidation among our accounts and other enterprises in the markets in which we operate may result in loss of business.***

It is likely that some of our existing accounts will consolidate, be acquired or experience a change in management, which could lead to a decrease in the size of our account base. We expect consolidation among our accounts as they attempt to strengthen or maintain their market positions. If two or more of our accounts consolidate, they may also wish to consolidate the software solutions and services that we provide to them. If an existing account is acquired by another company that uses the solutions of one of our competitors, we may lose business in that account to our competitor. In addition, if an account experiences a change in management, the new management team may be accustomed to the software of one of our competitors, and we could lose that account. Any such consolidation, acquisition or management change could lead to pricing pressure, erosion of our margins, loss of accounts and loss of market share, all of which could harm our business, financial condition, and results of operations.

***We have in the past and expect to continue in the future to seek to grow our business through acquisitions of or investments in new or complementary businesses, software solutions or technologies, and the failure to manage acquisitions or investments, or the failure to integrate them with our existing platform and business, could harm us.***

Since our founding, we have strategically acquired and integrated numerous software assets and businesses. We may, however, be unable to identify suitable acquisition candidates in the future or, if suitable candidates are identified, we may be unable to complete the business combination on commercially acceptable terms. The process of exploring and pursuing acquisition opportunities may result in devotion of significant management and financial resources.

Even if we are able to consummate acquisitions that we believe will be successful, these transactions present many risks including, among others:

- failing to achieve anticipated synergies and revenue increases;
- difficulty incorporating and integrating the acquired technologies or software solutions with our offerings, and existing applications;
- difficulties managing an acquired company's technologies or lines of business or entering new markets where we have limited prior experience or where competitors may have stronger market positions;
- maintaining the quality standards that are consistent with our brand and reputation;

- difficulty in coordinating, establishing or expanding sales, distribution and marketing functions, as necessary;
- disruption of our ongoing business and diversion of management’s attention to transition or integration issues;
- the potential that due diligence of the acquired business or product does not identify significant problems;
- exposure to litigation or other claims in connection with, or inheritance of claims or litigation risk as a result of, an acquisition, including but not limited to, claims from terminated colleagues, accounts, or other third parties;
- unanticipated and unknown liabilities, including for intellectual property infringement;
- increases in our interest expense, leverage and debt service requirements if we incur additional debt to pay for an acquisition;
- if we were to issue a significant amount of equity securities in connection with future acquisitions, dilution to existing stockholders and potential decreases in earnings per share;
- the loss of key colleagues, accounts and channel partners of ours or of the acquired company; and
- difficulties implementing and maintaining sufficient controls, policies and procedures over the systems, software and processes of the acquired company.

We may also incur unanticipated costs, expenses or other liabilities as a result of an acquisition target’s violation of applicable laws, such as the Foreign Corrupt Practices Act (“FCPA”) or similar worldwide anti-bribery and anti-corruption laws in foreign jurisdictions, as well as data security and privacy laws such as the GDPR. If we do not achieve the anticipated benefits of our acquisitions as rapidly or to the extent anticipated by management and financial or industry analysts, or if we are subject to unanticipated costs, expenses or other liabilities in connection with our acquisitions, there could be an adverse effect on our stock price, business, financial position, results of operations or cash flows.

We may not be successful in overcoming such risks, and such acquisitions may negatively impact our business. In addition, such acquisitions may contribute to potential fluctuations in our quarterly financial results. These fluctuations could arise from transaction-related costs and charges associated with eliminating redundant expenses or write-offs of impaired assets recorded in connection with acquisitions. These costs or charges could negatively impact our financial results for a given period, cause quarter to quarter variability in our financial results or negatively impact our financial results for several future periods.

***Increasingly stringent and growing data protection and privacy laws with respect to cloud computing, cross-border data transfer restrictions and other restrictions may apply to our business and non-compliance with such rules may limit the use and adoption of our services and adversely affect our business.***

As a global software and service provider, we collect and process personal data and other data from our users and prospective users. We use this information to provide solutions and applications to our accounts, to validate user identity, to fulfill contractual duties and administer billing and support, to expand and improve our business, and to communicate and recommend products and services through our marketing and advertising efforts. We may also share accounts’ personal data with certain third parties as described in the privacy policy provided to each account. As a result, we are required to comply with local laws and regulations, including data protection requirements in the countries where we do business.

Globally, new and evolving regulations regarding data protection and privacy and other standards governing the collection, processing, storage and use of personal data impose additional burdens for us due to increasing compliance standards that could restrict the use and adoption of our solutions and applications (in particular cloud services).

We have significant business operations in the European Union (“E.U.”) and European Economic Area (“EEA”), where the GDPR went into effect on May 25, 2018. The GDPR harmonized data protection regulations across the E.U. and EEA, implementing stringent requirements for the protection of E.U. and

EEA individuals' ("data subjects") personal data. These requirements include expanded requirements for our users as E.U. and EEA data subjects, new obligations on us as data controllers and processors, and mandatory breach notification to affected individuals and data protection supervisory authorities. Non-compliance with GDPR could result in fines and penalties up to the greater of €20 million or 4% of global turnover for the preceding financial year. Moreover, individuals can claim damages resulting from infringement of the GDPR. As a result of the GDPR, as a personal data processor for our business-to-business accounts we must commit to detailed contractual obligations, including to ensure we only process such data on our accounts' instructions, keep it secure, require our sub-processors to commit to similar commitments, delete data when the contract ends and let our accounts audit our compliance.

In addition, E.U. and EEA data protection rules regulate the transfers of E.U. and EEA individuals' personal data to other countries that have been deemed by the European Commission not to provide adequate protection to personal data. The United States is not deemed to have adequate laws to protect personal data. We had relied upon the E.U.-U.S. Privacy Shield program to legitimize certain transfers of personal data from the E.U. and EEA to the United States. However, on July 16, 2020, the European Court of Justice ("ECJ") invalidated the E.U.-U.S. Privacy Shield program that we (along with thousands of other companies) have used to transfer data from the E.U. and EEA to the United States in compliance with GDPR. As a result of this decision, companies like us that previously relied upon Privacy Shield will be required to use another GDPR-approved method to legitimize transfers of personal data to the U.S. and other third countries in compliance with the GDPR. Until the remaining legal uncertainties regarding how to legally continue these transfers are settled, we will continue to face uncertainty as to whether our efforts to comply with our obligations under European privacy laws will be sufficient. Our accounts may view alternative data transfer mechanisms as being too costly, too burdensome, too legally uncertain or otherwise objectionable and therefore decide not to do business with us. For example, some of our accounts or potential accounts in the E.U. may require their vendors to host all personal data within the E.U. and may decide to do business with one of our competitors who hosts personal data within the E.U. instead of doing business with us. This and other future developments regarding the flow of data across borders could increase the cost and complexity of delivering our products and services in some markets and may lead to governmental enforcement actions, litigation, fines and penalties or adverse publicity, which could have an adverse effect on our reputation and business.

Further, laws such as the E.U.'s Privacy and Electronic Communications Directive 2002 ("ePrivacy Directive"), national legislation across the E.U. implementing the ePrivacy Directive and the proposed ePrivacy Regulation are increasingly aimed at the use of personal data for marketing purposes, and the tracking of individuals' online activities. These existing or proposed laws and regulations are subject to differing interpretations and may be inconsistent among jurisdictions and member states. These and other requirements may have a negative effect on businesses, including ours, that collect and use online usage information for consumer acquisition and marketing. As the text of the ePrivacy Regulation is still under development, and as further guidance is issued and interpretation of both the ePrivacy Regulation and GDPR develop, we could incur costs to comply with these regulations.

In addition, despite the enactment of the UK Data Protection Act, which substantially implements the GDPR and became effective in May 2018, it remains unclear exactly how the withdrawal of the United Kingdom from the European Union will affect transborder data flows, regulators' jurisdiction over our business, and other matters related to how we do business and how we comply with applicable data protection laws. Accordingly, we cannot predict the additional expense, impact on revenue, or other business impact that may stem from the United Kingdom's withdrawal from the European Union at this time.

In the Asia-Pacific region, where we have significant business operations, changes in privacy and cybersecurity regulation, some of which is similar to changes effected by the GDPR, have come into effect in 2018 and 2019, and similar significant regulatory changes are expected across the Asia-Pacific region in the future. These changes introduce more stringent requirements, including that we register our data processing activities in certain jurisdictions, appoint local representatives in-country, restrict the cross-border transfer of personal, confidential and commercially sensitive information in some cases, provide expanded disclosures to tell our accounts about how we use their personal information, and obtain detailed consents from accounts to processing of personal information. There are also increased rights for accounts to access, control and delete their personal information. In addition, there are mandatory data breach notification

requirements that differ depending on the jurisdiction as well as increases to penalties and expanded enforcement powers for regulators.

We also expect that there will continue to be new proposed laws, regulations and industry standards concerning privacy, data protection and information security in the United States, the E.U., the EEA, and other jurisdictions, and we cannot yet determine the impact such future laws, regulations and standards may have on our business. For example, in June 2018 California enacted the California Consumer Privacy Act (the “CCPA”), which took effect on January 1, 2020. The CCPA broadly defines personal information, gives California residents expanded privacy rights and protections and provides for civil penalties for violations and a private right of action for data breaches. In addition to government activity, privacy advocacy groups and technology and other industries are considering various new, additional or different self-regulatory standards that may place additional burdens on us. Future laws, regulations, standards and other obligations, and changes in the interpretation of existing laws, regulations, standards and other obligations could impair our ability to collect, use or disclose personally identifiable information, increase our costs and impair our ability to maintain and grow our account base and increase our revenue. New laws, amendments to or re-interpretations of existing laws and regulations, industry standards, contractual obligations and other obligations may require us to incur additional costs and restrict our business operations. Such laws and regulations may require companies to implement privacy and security policies, permit users to access, correct and delete personal data stored or maintained by such companies, inform individuals of security breaches that affect their personal data, and, in some cases, obtain individuals’ consent to use personal data for certain purposes. If we, or the third parties on which we rely, fail to comply with federal, state and international data privacy laws and regulations, our ability to successfully operate our business and pursue our business goals could be harmed.

Our failure to comply with applicable laws and regulations, or to protect such data, could result in enforcement action against us, including fines and public censure, claims for damages by accounts and other affected individuals, damage to our reputation and loss of goodwill (both in relation to existing accounts and prospective accounts), any of which could harm our business, financial condition, and results of operations.

Around the world, there are numerous lawsuits in process against various technology companies that process personal data. If those lawsuits are successful, it could increase the likelihood that our company may be exposed to liability for our own policies and practices concerning the processing of personal data and could hurt our business.

In addition to government activity, privacy advocacy and other industry groups have established or may establish new self-regulatory standards that may place additional burdens on us. Our accounts expect us to meet voluntary certification or other standards established by third parties or imposed by the accounts themselves. If we are unable to maintain these certifications or meet these standards, it could adversely affect our ability to provide our solutions to certain accounts and could harm our business. Further, if we were to experience a breach of systems compromising our accounts’ sensitive data, our brand and reputation could be adversely affected, use of our software solutions and services could decrease, and we could be exposed to a risk of loss, litigation, and regulatory proceedings.

The costs of compliance with and other burdens imposed by laws, regulations and standards may limit the use and adoption of our services and reduce overall demand for it, or lead to significant fines, penalties or liabilities for any noncompliance.

Furthermore, concerns regarding data privacy may cause our accounts’ customers to resist providing the data necessary to allow our accounts to use our services effectively. Even the perception that the privacy of personal information is not satisfactorily protected or does not meet regulatory requirements could inhibit sales of our software solutions or services, and could limit adoption of our cloud-based solutions.

***We depend on our senior management team and other key personnel, and we could be subject to substantial risk of loss if any of them terminate their relationship with us.***

Our success depends upon the continued services of our key personnel, including Barry J. Bentley, Gregory S. Bentley, Keith A. Bentley and Raymond B. Bentley. These individuals and each of our other

executive officers, key technical personnel, and colleagues could terminate his or her relationship with us at any time. Failure to effectively implement our succession planning efforts and to ensure effective transfers of knowledge and smooth transitions involving key personnel could disrupt or adversely affect our business and results of operations. Additionally, Barry J. Bentley, Gregory S. Bentley, Keith A. Bentley and Raymond B. Bentley and most of our senior management team and other key personnel are not subject to employment or other agreements containing non-compete provisions. Accordingly, the adverse effect resulting from the loss of certain key personnel could be compounded by our inability to prevent them from competing with us. Further, we do not maintain key person insurance on any of our senior management team or other key personnel in the event of their death or extended incapacity. The loss of any of our senior executives might significantly delay or prevent the achievement of our business objectives and could harm our business and account relationships.

***If we are not successful in attracting, integrating and retaining highly qualified personnel, we may not be able to successfully implement our business strategy.***

Our ability to establish and maintain a position of technology leadership in the highly competitive software market depends in large part upon our ability to attract, integrate and retain highly skilled engineering and development personnel in the United States and internationally. The market for this talent is highly competitive, and our recruiting efforts are widespread and conducted in varying hiring climates throughout the world. Due to restrictive immigration laws in the United States, we are also sometimes limited in our ability to integrate our international colleagues to locations where their skills may be particularly well-suited. If we are not successful in recruiting and retaining key personnel or integrating our personnel effectively, our business, reputation and results of operations could be adversely affected.

***Quality problems, defects, errors, failures, or vulnerabilities in our software solutions or services could harm our reputation and adversely affect our business, financial condition, results of operations, and prospects.***

Our solutions are, in some cases, highly complex and incorporate advanced software technologies that we attempt to make interoperable with the products of other software providers. Despite testing prior to release, our software may contain undetected defects or errors. Further, the combined use of our software with those of other software providers may cause errors or failures, or it may expose undetected defects, errors or failures in our software. These defects, errors, or failures could affect software performance and damage the businesses of our accounts as well as delay the development or release of new software or new versions of software. Further, we cannot guarantee that all of our accounts are using the latest versions of our software solutions with enhanced security features, and may be more vulnerable to cyber attacks. Allegations of unsatisfactory performance in any of these situations could damage our reputation in the market and our relationships with our accounts, cause us to lose revenue or market share, increase our service costs, cause us to incur substantial costs in analyzing, correcting or redesigning the software, cause us to lose accounts, subject us to liability for damages and divert our resources from other tasks, any one of which could adversely affect our business, financial condition, results of operations, and prospects. We may also be required to provide full replacements or refunds for such defective software. We cannot assure you that such remediation would not harm our business, financial condition, results of operations, and prospects.

***Our business, financial condition, results of operations, and prospects may be harmed if we are unable to cross-sell our solutions.***

A significant component of our growth strategy is to increase the cross-selling of our solutions to current and future accounts, however, we may not be successful in doing so if our accounts find our additional solutions to be unnecessary or unattractive. We have invested, and intend to continue to invest, significant resources in developing and acquiring additional solutions, which resources may not be recovered if we are unable to successfully cross-sell these solutions to accounts using our existing solutions. Any failure to sell additional solutions to current and future accounts could harm our business, financial condition, results of operations, and prospects.

***We license third-party technologies for the development of certain of our software solutions, and, in some instances, we incorporate third-party technologies, including open source software, into our software solutions. If we fail to maintain these licenses or are unable to secure alternative licenses on reasonable terms, our business could be adversely affected.***

We license third-party technologies to develop certain of our products, and, in some cases, we incorporate third-party technologies into our own software solutions, including technologies owned by our

competitors. If we were to seek to expand the scope of this activity in the future, we could be required to obtain additional licenses and enter into long-term arrangements with third parties on whose technology we could become substantially dependent.

If we are unable to use or license these third-party technologies on reasonable terms, including commercially justifiable royalty rates, or if these technologies fail to operate properly or be appropriately supported, maintained or enhanced, we may not be able to secure alternatives in a timely manner and our ability to develop and commercialize our own software solutions could be adversely impacted. In addition, licensed technology may be subject to claims that it infringes others' intellectual property rights, and we may lose access to or have restrictions placed on our use of the licensed technology.

Furthermore, we are unable to predict whether future license agreements and arrangements with third parties can be obtained, and, if obtained, whether they can be renewed on acceptable terms, or at all. If we become substantially dependent upon any such third-party technology and we are unable to successfully license it, we may not be able to develop or commercialize our software solutions in a timely manner or at all. Any of the foregoing could adversely impact our business and results of operations.

We also incorporate open source software into our products. While we have attempted not to use open source code in a manner which could adversely impact our proprietary code, the terms of many open source licenses have not been interpreted by U.S. courts, and there is a risk that such licenses could be construed in a manner that could impose unanticipated conditions or restrictions on our ability to market or sell our products or to develop new products. In such event, we could be required to seek licenses from third-parties in order to continue offering our products, to disclose and offer royalty-free licenses to our own source code, to re-engineer our products, or to discontinue the sale of our products in the event re-engineering cannot be accomplished on a timely basis, any of which could adversely impact our business and results of operations.

***As a result of our strategy of strategic partnerships with other companies for product development, our product delivery schedules could be adversely affected if we experience difficulties with our product development partners.***

We have strategic partnerships with certain independent firms and contractors to perform some of our product development activities. We believe our strategic partnerships allow us to, among other things, achieve efficiencies in developing new products and maintaining and enhancing existing product offerings. Our strategic partnerships create a dependency on such independent developers. Independent developers, including those who currently develop solutions for us in the United States and throughout the world, may not be able or willing to provide development support to us in the future. In addition, use of development resources through consulting relationships, particularly in non-U.S. jurisdictions with developing legal systems, may be adversely impacted by, and expose us to risks relating to, evolving employment, export and intellectual property laws. These risks could, among other things, expose our intellectual property to misappropriation and result in disruptions to product delivery schedules, which in turn could harm our business, financial condition, and results of operations.

***The United Kingdom's withdrawal from the European Union may have a negative effect on global economic conditions, financial markets and our business.***

The United Kingdom's withdrawal from the European Union ("Brexit") has created political and economic uncertainty, particularly in the United Kingdom and the European Union, and this uncertainty may last for years. Demand for our software solutions or services could be affected by the impact of Brexit. For example, while we have invoiced our U.K.-based accounts and operated our business within the United Kingdom through our U.K.-based subsidiary since the fourth quarter of 2018 to manage risks posed to our business and operations by Brexit, Brexit may cause delays in purchasing decisions by our potential and current accounts affected by this transition and there is considerable uncertainty as to when the long-term nature of the United Kingdom's relationship with the European Union will be agreed and implemented and what the terms of that relationship will be. The final terms of this exit by the United Kingdom from the European Union may result in new regulatory and cost challenges to our U.K. and global operations. In addition, our business and our channel partners' businesses could be negatively affected by new trade agreements between the United Kingdom and other countries, including the United States



and by the possible imposition of trade or other regulatory barriers in the United Kingdom. The unresolved final terms of Brexit have also created uncertainty with regard to the regulation of data protection in the United Kingdom. For example, the UK Data Protection Act, which substantially implements the GDPR, became effective in May 2018. It remains unclear, however, how United Kingdom data protection laws or regulations will develop and be interpreted in the medium to longer term, how data transfers to and from the United Kingdom will be regulated, and how those regulations may differ from those in the European Union. Depending on the terms reached regarding any exit from the European Union, it is possible that there may be adverse practical or operational implications on our business. Further, the United Kingdom's exit from the European Union may create increased compliance costs and an uncertain regulatory landscape for offering equity-based incentives to our employees in the United Kingdom. If we are unable to maintain equity-based incentive programs for our employees in the United Kingdom due to the departure of the United Kingdom from the European Union, our business in the United Kingdom may suffer and we may face legal claims from employees in the United Kingdom to whom we previously offered equity-based incentive programs.

***There are significant costs and restrictions associated with the repatriation of cash from our non-U.S. operations.***

Our cash and cash equivalents balances are concentrated in a few locations around the world, with approximately 98% of those balances held outside of the United States as of December 31, 2019. Cash repatriation restrictions may limit our ability to repatriate cash held by our foreign subsidiaries. Additionally, the repatriation of cash held by our foreign subsidiaries may result in adverse tax consequences. Any repatriation of cash may be restricted or may result in our incurring substantial costs. As a result, we may be required to seek sources of cash to fund our operations, including through the issuance of equity securities, which may be dilutive to existing stockholders, or by incurring additional indebtedness. There can be no assurance that we will be able to secure sources of financing on terms favorable to us, or at all.

***Assertions by third parties of infringement or other violations by us of their intellectual property rights could result in significant costs and harm our business and results of operations.***

Vigorous protection and pursuit of intellectual property rights has resulted in protracted and expensive litigation for many companies in our industry. Although claims of this kind have not materially affected our business to date, there can be no assurance such claims will not arise in the future. Any claims or proceedings against us, regardless of whether meritorious, could be time consuming, result in costly litigation, require significant amounts of management time, result in the diversion of significant operational resources, or require us to enter into royalty or licensing agreements, any of which could harm our business, financial condition, and results of operations.

Intellectual property lawsuits are subject to inherent uncertainties due to the complexity of the technical issues involved, and we cannot be certain that we will be successful in defending ourselves against intellectual property claims. In addition, we may not be able to effectively use our intellectual property portfolio to assert defenses or counterclaims in response to copyright, patent and trademark infringement claims or litigation, as well as claims for trade secret misappropriation and unfair competition, brought against us by third parties. Further, litigation may involve patent holding companies or other adverse patent owners who have no relevant products and against whom our patent portfolio may provide little or no deterrence.

Many potential litigants have the capability to dedicate substantially greater resources to enforce their intellectual property rights and to defend claims that may be brought against them. Furthermore, a successful claimant could secure a judgment that requires us to pay substantial damages or prevents us from distributing certain solutions or performing certain services. We might also be required to seek a license and pay royalties for the use of such intellectual property, which may not be available on commercially acceptable terms or at all. Alternatively, we may be required to develop non-infringing technology, which could require significant effort and expense and may ultimately not be successful.

***If our solutions infringe on the intellectual property rights of others, we may be required to indemnify our accounts for any damages they suffer.***

We generally indemnify our accounts with respect to infringement by our products of the proprietary rights of third parties. Third parties may assert infringement claims against our accounts. These claims may

require us to initiate or defend protracted and costly litigation on behalf of our accounts, regardless of the merits of these claims. If any of these claims succeed, we may be forced to pay damages on behalf of our accounts or may be required to obtain licenses for the products they use. If we cannot obtain all necessary licenses on commercially reasonable terms, our accounts may stop using our products.

***Pricing pressure from our competitors and our accounts may impact our ability to sell our software solutions at prices necessary to support our current business strategies.***

The intense competition we face in the sales of our software solutions and services, and general economic and business conditions, can put pressure on us to lower our prices. If our competitors offer deep discounts on certain software solutions or services, or develop software solutions that the marketplace considers more valuable, we may need to lower prices or offer discounts or other favorable terms to compete successfully. Any such changes may reduce operating margins and could adversely affect results of operations. Any broad-based change to our prices and pricing policies could cause new software subscription and service revenues to decline or be delayed as our sales force implements and our accounts adjust to the new pricing policies.

***Our credit agreement contains restrictive covenants that may limit our operating flexibility, and certain changes in ownership of equity interests in us by the Bentley Family constitutes an event of default.***

The agreement governing the Credit Facility contains certain restrictive covenants that limit our ability to, among other things, incur indebtedness other than amounts under the Credit Facility and specified baskets, incur additional liens, merge or consolidate with other companies or consummate certain changes of control, enter into new lines of business, pay dividends to our stockholders, make investments in and acquire other businesses and transfer or dispose of assets. In certain circumstances, the agreement governing the Credit Facility may also limit our ability to transfer cash among our subsidiaries and between us and our subsidiaries, including our foreign subsidiaries. It also contains certain financial covenants, including a covenant requiring us not to permit the net leverage ratio to exceed 3.50 to 1.00 and a covenant requiring the fixed charge coverage ratio for any period of four consecutive fiscal quarters to not be less than 3.0 to 1.00, and financial reporting requirements. Borrowings under the Credit Facility are secured by a first priority security interest in substantially all of our U.S. assets and 65% of the stock our foreign subsidiaries owned by a party to the agreement governing the Credit Facility.

Further, if the Bentley Family ceases to collectively own equity interests in us representing at least a majority of the aggregate voting power of the Company, then such change in ownership will be an event of default under the agreement governing the Credit Facility and, among other things, the commitments under the Credit Facility may be terminated immediately and the outstanding loans and accrued interest may become due and payable immediately.

In addition, there is no guarantee that we will be able to generate sufficient cash flow or revenues to meet these financial covenants or pay the principal and interest on any debt. Furthermore, there is no guarantee that future working capital, borrowings or equity financing will be available to repay or refinance any debt. Any inability to make scheduled payments or meet the financial covenants in the agreement governing the Credit Facility would adversely affect our business.

***The phase-out of LIBOR could affect interest rates under our Credit Facility.***

On July 27, 2017, the United Kingdom's Financial Conduct Authority announced it intends to stop compelling banks to submit rates for the calculation of the London Interbank Offered Rate ("LIBOR") after 2021. It is unclear if LIBOR will cease to exist at that time, if a new method of calculating LIBOR will be established, or if an alternative reference rate will be established. The Federal Reserve Board and the Federal Reserve Bank of New York organized the Alternative Reference Rates Committee, which identified the Secured Overnight Financing Rate ("SOFR") as its preferred alternative to U.S. dollar LIBOR in derivatives and other financial contracts. We are not able to predict when LIBOR will cease to be available or if SOFR, or another alternative reference rate, attains market traction as a LIBOR replacement. LIBOR is used as the reference rate for Euro currency borrowings under our Credit Facility and as one of the alternatives for U.S. Dollar borrowings under our Credit Facility. If LIBOR ceases to exist, the administration agent under our Credit Facility has the authority to select a benchmark replacement index and adjustment

margins and, as such, the interest rate on Euro currency borrowings under our Credit Facility may change. The new rate may not be as favorable as those in effect prior to any LIBOR phase-out. Furthermore, the transition process may result in delays in funding, higher interest expense, additional expenses, and increased volatility in markets for instruments that currently rely on LIBOR, all of which could negatively impact our interest expense, results of operations, and cash flow.

***We may incur substantial additional debt, which could exacerbate the risks described above.***

We may incur additional debt in the future. Although the agreement governing the Credit Facility contains restrictions on our ability to incur indebtedness, those restrictions are subject to a number of exceptions which permit us and our subsidiaries to incur substantial debt. Adding new debt to current debt levels could intensify the related risks that we and our subsidiaries now face. See the section titled “Management’s Discussion and Analysis of Financial Condition and Results of Operations — Liquidity and Capital Resources.”

***We may need to raise additional capital, which may not be available to us.***

We may require substantial funds to operate our business and pursue our strategies. Our future liquidity and capital requirements are difficult to predict as they depend upon many factors, including the success of our solutions and competing technological and market developments. In the future, we may require additional capital to respond to business opportunities, challenges, acquisitions, a decline in the level of account prepayments or unforeseen circumstances and may determine to engage in equity or debt financings or enter into credit facilities for other reasons, and we may not be able to timely secure additional debt or equity financing on favorable terms, or at all. Any additional debt financing obtained by us in the future could involve restrictive covenants relating to our capital raising activities and other financial and operational matters, which may make it more difficult for us to obtain additional capital and to pursue business opportunities, including potential acquisitions. If we raise funds through issuances of equity, convertible debt securities or other securities convertible into equity, our existing stockholders could suffer significant dilution in their percentage ownership of our company. If we are unable to obtain adequate financing or financing on terms satisfactory to us when we require it, our ability to continue to grow or support our business and to respond to business challenges could be significantly limited.

***From time to time we realign or introduce new business initiatives, including reorganizing our sales and marketing, research and development and administrative functions; if we fail to successfully execute and manage these initiatives, our results of operations could be negatively impacted.***

We rely heavily on our direct sales force. From time to time, we reorganize and make adjustments to our sales leadership and/or our sales force in response to such factors as management changes, performance issues, market opportunities and other considerations. These changes may result in a temporary lack of sales production and may adversely impact revenues in future quarters. Market acceptance of any new business or sales initiative is dependent on our ability to match our accounts’ needs at the right time and price. There can be no assurance that we will not restructure our sales force in future periods or that the transition issues associated with such a restructuring will not occur. Similarly, reorganization of our research and development and administrative functions can disrupt our operations and negatively impact our results of operations if the execution is not managed properly. If any of our assumptions about expenses, revenues or revenue recognition principles from these initiatives proves incorrect, or our attempts to improve efficiency are not successful, our actual results may vary materially from those anticipated, and our financial results could be negatively impacted.

***We may have to invest more resources in research and development than anticipated, which could increase our operating expenses and negatively affect our results of operations.***

We devote substantial resources to research and development. New competitors, technological advances in the software industry or by competitors, our acquisitions, our entry into new markets, or other competitive factors may require us to invest significantly greater resources than we anticipate. If we are required to invest significantly greater resources than anticipated without a corresponding increase in

revenue, our results of operations could decline. Additionally, our periodic research and development expenses may be independent of our level of revenue, which could negatively impact our financial results.

Further, technology for which we spend a significant amount of time and resources on in our research and development, such as our digital twin technology, may prove to be less marketable than we expect. There can be no guarantee that our research and development investments will result in products that create additional revenue.

***A portion of our revenues are from sales by our channel partners, and we could be subject to loss or liability based on their actions.***

Sales through our global network of independent, regional channel partners accounted for 9% and 8% of our revenues for the years ended December 31, 2018 and 2019, respectively. These channel partners sell our software solutions to smaller accounts, in geographic regions where we do not have a meaningful presence, and in niche markets where they have specialized industry and technical knowledge. Where we rely on channel partners, we may have reduced contact with ultimate users that purchase through such channel partners, thereby making it more difficult to establish brand awareness, ensure proper installation, service ongoing requirements, estimate demand and respond to the evolving needs of an account. Any of our channel partners may choose to terminate its relationship with us at any time. As a result, our ability to service the ultimate users who were interfacing with that channel partner may take time to develop as we divert resources to service those users directly or find a suitable alternative channel partner to continue the relationship. Any disruption in service may damage our reputation and business. In addition, our channel partners may be unable to meet their payment obligations to us, which would have a negative impact on our results of operations and revenues. Our channel partners may also not have loyalty to our brand and therefore may not be particularly motivated to sell our software solutions or services.

The use of channel partners could also subject us to lawsuits, potential liability and reputational harm if, for example, any channel partners misrepresent the functionality of our software solutions or services to accounts, fail to comply with their contractual obligations or violate laws or our corporate policies. Such actions may impact our ability to distribute our software solutions into certain regions and markets, and may have an adverse effect on our results of operations and cash flows.

***Some of our solutions are complex, and accounts may experience difficulty in implementing, upgrading or otherwise achieving the benefits attributable to them.***

Due to the scope and complexity of some of the solutions that we provide, our implementation cycle for them can be lengthy and unpredictable. Some solutions require configuration and integration with existing computer systems and applications of our accounts and their trading partners, which can be time-consuming and expensive for our accounts and can result in implementation delays. As a result, some accounts may have difficulty implementing those solutions successfully or otherwise achieving their expected benefits. Delayed or ineffective implementation or upgrades may limit our future sales opportunities, negatively affect revenue, result in account dissatisfaction and harm our reputation.

***Determining our effective income tax rate is complex and subject to uncertainty.***

We make significant estimates in determining our worldwide income tax provision. These estimates involve complex tax laws and regulations in a number of jurisdictions across our global operations and are subject to many transactions and calculations in which the ultimate tax outcome is uncertain. The final outcome of tax matters could be different than the estimates reflected in the historical income tax provision and related accruals. These differences could have a material impact on income tax expense and net income in the periods in which such determinations are made.

The amount of income tax we pay is subject to ongoing audits by federal, state and foreign tax authorities. These audits can often result in additional assessments, including interest and penalties. Our estimate for liabilities associated with uncertain tax positions is highly judgmental and actual future outcomes may result in favorable or unfavorable adjustments to our estimated tax liabilities, including estimates for uncertain tax positions, in the period the assessments are made or resolved, audits are closed or when statutes

of limitation on potential assessments expire. As a result, our effective tax rate may fluctuate significantly on a quarterly or annual basis.

***The intended efficiency of our corporate structure depends on the application of the tax laws and regulations in the countries where we operate, and we may have exposure to additional tax liabilities or our effective tax rate could change, which could have a material impact on our financial condition and results of operations.***

As a company with international operations, we are subject to income taxes, as well as non-income based taxes, in both the United States and various foreign jurisdictions. Currently, the majority of our revenues is generated from accounts located outside the United States, and a large portion of our assets are located outside the United States. We have designed our corporate structure, the manner in which we develop and use our intellectual property, and our intercompany transactions between our subsidiaries in a way that is intended to enhance our operational and financial efficiency and increase our overall profitability. United States income taxes and foreign withholding taxes have not been provided on undistributed earnings of non-U.S. subsidiaries to the extent those earnings are considered to be indefinitely reinvested in the operations of those subsidiaries. The application of the tax laws and regulations of various countries in which we operate and to our global operations is subject to interpretation. We also must operate our business in a manner consistent with our corporate structure to realize such efficiencies. The tax authorities of the countries in which we operate may challenge our methodologies for valuing developed technology or for transfer pricing. If, for one or more of these reasons, tax authorities determine that the manner in which we operate results in our business not achieving the intended tax consequences, our effective tax rate could increase and harm our financial condition and results of operations.

A change in the tax law in the jurisdictions in which we do business, including an increase in tax rates, an adverse change in the treatment of an item of income or expense, a decrease in tax rates in a jurisdiction in which we have significant deferred tax assets, or a new or different interpretation of applicable tax law, could result in a material increase in tax expense. The United States government and other governments are considering and may adopt tax law changes that significantly increase our worldwide tax liabilities. The U.S. Congress and other government legislatures and agencies in countries where we and our subsidiaries operate have focused on issues related to the taxation of multinational corporations. For example, in Ireland, where one of our significant subsidiaries is domiciled, tax authorities recently announced changes to the treatment of non-resident Irish entities. The changes are expected to take effect for existing non-resident Irish entities, such as ours, in 2021. These changes, and other prospective changes in the United States and other countries in which we and our subsidiaries operate, could increase our effective tax rate, and harm our financial condition and results of operations.

***We are subject to legal proceedings and regulatory inquiries, and we may be named in additional legal proceedings or become involved in regulatory inquiries in the future, any of which may be costly, distracting to our core business and could result in an unfavorable outcome, or harm on our business, financial condition, results of operations, cash flows, or the trading price for our securities.***

We are subject to various investigations, claims and legal proceedings that arise in the ordinary course of business, including commercial disputes, labor and employment matters, tax audits, alleged infringement of intellectual property rights and other matters. As the global economy has changed, our industry has seen an increase in litigation activity and regulatory inquiries. Like many other high technology companies, on a regular and ongoing basis, we receive inquiries from U.S. and foreign regulatory agencies regarding our business and our business practices, and the business practices of others in our industry. In the event that we are involved in significant disputes or are the subject of a formal action by a regulatory agency, we could be exposed to costly and time consuming legal proceedings that could result in any number of outcomes. Any claims or regulatory actions initiated by or against us, whether successful or not, could result in expensive costs of defense, costly damage awards, injunctive relief, increased costs of business, fines or orders to change certain business practices, significant dedication of management time, diversion of significant operational resources, or otherwise harm our business. In any of these cases, our financial results could be negatively impacted.

***Failure to comply with the FCPA and similar anti-bribery and anti-corruption laws associated with our activities outside the United States could subject us to penalties and other adverse consequences.***

The majority of our revenues are from jurisdictions outside of the United States. We are subject to the FCPA, which generally prohibits U.S. companies and their intermediaries from making payments to foreign

officials for the purpose of directing, obtaining or keeping business, and requires companies to maintain reasonable books and records and a system of internal accounting controls. The FCPA applies to companies and individuals alike, including company directors, officers, employees and agents. Under the FCPA, U.S. companies may be held liable for corrupt actions taken by employees, strategic or local partners or other representatives. In addition, the government may seek to rely on a theory of successor liability and hold us responsible for FCPA violations committed by companies or associated with assets that we acquire.

In many foreign jurisdictions where we operate, particularly countries with developing economies, it may be a local custom for businesses to engage in practices that are prohibited by the FCPA or other similar laws and regulations. There can be no assurance that our colleagues, partners and agents, as well as those companies to which we outsource certain of our business operations, will not take actions in violation of the FCPA or our policies for which we may be ultimately held responsible. If we or our intermediaries fail to comply with the requirements of the FCPA or similar anti-bribery and anti-corruption legislation such as the United Kingdom Bribery Act and the China Unfair Competition law, governmental authorities in the United States and elsewhere could seek to impose civil and/or criminal fines and penalties, which could harm our business, financial conditions, and results of operations. We may also face collateral consequences such as debarment and the loss of our export privileges.

***We are subject to governmental export and import controls that could impair our ability to compete in international markets or subject us to liability if we violate the controls.***

Our offerings may be subject to U.S. export controls and economic sanctions laws and regulations that restrict the delivery of our solutions and services to certain locations, governments, and persons. While we have processes in place to prevent our offerings from being exported in violation of these laws, including obtaining authorizations as appropriate and screening against U.S. government lists of restricted and prohibited persons, we cannot guarantee that these processes will prevent all violations of export control and sanctions laws. We may also decide to acquire companies whose past activities could give rise to potential liability under export control and sanctions laws. Such acquisitions may require substantial time and resources to integrate the acquired company into our compliance processes, to correct potential compliance gaps, and to remediate past potential violations by the acquired company, including through our own internal actions, voluntary self-disclosures or other measures.

Further, if our channel partners fail to obtain appropriate import, export or re-export licenses or permits, we may also be adversely affected, for example, through reputational harm as well as other negative consequences including government investigations and penalties. Complying with export control and sanctions regulations for a particular sale may be time-consuming and may result in the delay or loss of sales opportunities.

Violations of U.S. sanctions or export control laws can result in fines, penalties, denial of export and trading privileges, and seizure of goods and assets. Other consequences include negative publicity and harm to business reputation, increased government scrutiny (including intrusive audits, and increased difficulty obtaining government licenses and approvals), and/or remedial compliance measures as a condition of settling government charges.

***Our business may be significantly disrupted upon the occurrence of a catastrophic event.***

Our business is highly automated and relies extensively on the availability of our network and data center infrastructure, our internal technology systems and our websites. We also rely on hosted computer services from third parties for services that we provide to our accounts and computer operations for our internal use. The failure of our systems or hosted computer services due to a catastrophic event, such as an earthquake, fire, flood, tsunami, weather event, pandemic, telecommunications failure, power failure, cyber attack, terrorism, or war, could adversely impact our business, financial condition, or results of operations. We have developed disaster recovery plans and maintain backup systems in order to reduce the potential impact of a catastrophic event, however there can be no assurance that these plans and systems would enable us to return to normal business operations. In addition, any such event could negatively impact a country or region in which we conduct business. This could in turn decrease that country's or region's demand for our products and services, thereby negatively impacting our financial results.

***We may face exposure to product or professional liability claims that could cause us to be liable for damages.***

The use of our software could lead to the filing of product liability claims against us were someone to allege that our software provided inaccurate or incomplete information at any stage of the infrastructure lifecycle or otherwise failed to perform according to specifications. In the event that accounts or third parties sustain property damage, injury, death or other loss in connection with their use of our software or infrastructure for which our software solutions and services were used to engineer, we, along with others, may be sued, and whether or not we are ultimately determined to be liable, we may incur significant legal expenses, management's attention could be diverted from operations and market acceptance of our software could decrease. Our risk of exposure to litigation in these situations could rise as our software solutions and services are used for increasingly complex and high-profile infrastructure projects. Litigation could also impair our ability to obtain professional liability or product liability insurance or increase the cost of such insurance. These claims may be brought by individuals seeking relief on their own behalf or purporting to represent a class. In addition, product liability claims may be asserted against us in the future based on events we are not aware of at the present time.

The limitations of our liability included in our contracts with accounts may not be enforceable or may not otherwise protect us from liability for damages. Additionally, we may be subject to claims that are not explicitly covered by contract, such as a claim directly by a third party. There is no assurance that our insurance coverage will be adequate to cover incurred liabilities or that we will be able to obtain acceptable product and professional liability coverage in the future.

***If the accounting estimates we make, and the assumptions on which we rely, in preparing our financial statements prove inaccurate, our actual results may be adversely affected.***

Our financial statements have been prepared in accordance with U.S. GAAP. The preparation of these financial statements requires us to make estimates and judgments about, among other things, taxes, revenue recognition, stock-based compensation costs, investments, contingent obligations, allowance for doubtful accounts and intangible assets. These estimates and judgments affect the reported amounts of our assets, liabilities, revenues and expenses, and related disclosure of contingent assets and liabilities. We base our estimates on historical experience and on various other assumptions that we believe to be reasonable under the circumstances and at the time they are made. If our estimates or the assumptions underlying them are not correct, actual results may differ materially from our estimates and we may need to, among other things, accrue additional charges that could adversely affect our results of operations, which in turn could adversely affect our stock price. In addition, new accounting pronouncements and interpretations of accounting pronouncements have occurred and may occur in the future that could adversely affect our reported financial results.

***Changes in existing financial accounting standards or practices may harm our results of operations.***

Changes in existing accounting rules or practices, new accounting pronouncements rules, or varying interpretations of current accounting pronouncements practice could have a significant, adverse effect on our results of operations or the manner in which we conduct our business. Further, such changes could potentially affect our reporting of transactions completed before such changes are effective.

U.S. GAAP is subject to interpretation by the Financial Accounting Standards Board ("FASB"), the SEC and various bodies formed to promulgate and interpret appropriate accounting principles. A change in these principles or interpretations could have a significant effect on our reported financial results, and could affect the reporting of transactions completed before the announcement of a change. In particular, in February 2016, the FASB issued ASC 842, *Leases*, which supersedes the lease accounting guidance in ASC 840, *Leases*. The core principle of ASC 842 requires lessees to apply a dual approach, classifying leases as either finance or operating leases based on the principle of whether or not the lease is effectively a financed purchase by the lessee. This classification will determine whether lease expense is recognized based on an effective interest method or on a straight-line basis over the term of the lease. A lessee is also required to record a right-of-use asset and a lease liability for all leases with a term of greater than 12 months regardless of their classification. As an "emerging growth company," we are allowed under the JOBS Act to delay adoption of new or revised accounting pronouncements applicable to public companies until such pronouncements are made applicable to private companies. We have elected to take advantage of this extended

transition period under the JOBS Act with respect to ASC 842, which resulted in ASC 842 becoming effective for us beginning on January 1, 2020. Any difficulties in implementing these pronouncements could cause us to fail to meet our financial reporting obligations, which could result in regulatory discipline and harm investors' confidence in us.

We are evaluating the impact of the adoption of ASC 842 and currently believe the most significant impact upon adoption will be the recognition of material right-of-use assets and lease liabilities on our consolidated balance sheets associated with operating leases. We do not believe this standard will have a material impact on our consolidated statements of operations data.

***We are an "emerging growth company," and the reduced disclosure requirements applicable to "emerging growth companies" may make our Class B common stock less attractive to investors.***

We are an "emerging growth company," as defined in the JOBS Act, and we intend to take advantage of certain exemptions from various reporting requirements that are applicable to other public companies that are not "emerging growth companies," including, but not limited to, not being required to comply with the auditor attestation requirements of Section 404 of the Sarbanes-Oxley Act, reduced disclosure obligations regarding executive compensation in our periodic reports and proxy statements, and exemptions from the requirements of holding a nonbinding advisory vote on executive compensation and stockholder approval of any golden parachute payments not previously approved. Additionally, as an "emerging growth company" we are required to have only two years of audited financial statements and only two years of related selected financial data and Management's Discussion and Analysis of Financial Condition and Results of Operations disclosure. We may take advantage of these exemptions until we are no longer an "emerging growth company," which could be as long as five full fiscal years following the listing of our Class B common stock on The Nasdaq Global Select Market. We cannot predict if investors will find our Class B common stock less attractive because we will rely on these exemptions. If some investors find our Class B common stock less attractive as a result, there may be a less active trading market for our Class B common stock and the price of our Class B common stock may be more volatile.

We will remain an "emerging growth company" until the earliest to occur of: (i) the last day of the fiscal year in which we have more than \$1.07 billion in annual revenue; (ii) the date we qualify as a "large accelerated filer," with at least \$700 million of equity securities held by non-affiliates; (iii) the date on which we have issued, in any three-year period, more than \$1.0 billion in non-convertible debt securities; and (iv) the last day of the fiscal year ending after the fifth anniversary of the completion of this offering.

***Because we have elected under Section 107 of the JOBS Act to use the extended transition period with respect to complying with new or revised accounting standards, our financial statements may not be comparable to companies that comply with public company effective dates, making it more difficult for an investor to compare our results with other public companies.***

Section 107 of the JOBS Act provides that an emerging growth company can use the extended transition period provided in Section 7(a)(2)(B) of the Securities Act of 1933, as amended (the "Securities Act") by Section 102(b)(1) of the JOBS Act, for complying with new or revised accounting standards. In other words, as an emerging growth company we can delay the adoption of new or revised accounting standards that have different effective dates for public and private companies until those standards would otherwise apply to private companies, which will result in less available information for our investors. We have elected to take advantage of the benefits of this extended transition period. As a result, our financial statements may not be comparable to those of companies that comply with public company effective dates.

#### **Risks Related to the Ownership of Our Class B Common Stock**

***The share price of our Class B common stock may be volatile, and you may be unable to sell your shares at or above the offering price, if at all. Market volatility may affect the value of an investment in our Class B common stock and could subject us to litigation.***

Technology stocks have historically experienced high levels of volatility. There has been no public market for our Class B common stock prior to this offering. The initial public offering price for the shares of our Class B common stock will be determined through negotiations between us and representatives of the



underwriters and may not be indicative of prices that will prevail in the trading market. The market price of our Class B common stock could be subject to wide fluctuations in response to the risk factors listed in this prospectus, and others beyond our control, including:

- the number of shares of our Class B common stock publicly owned and available for trading (our “public float”);
- limited “public float” in the hands of a small number of investors following this offering whose trading or lack of trading could result in a volatile market price for our Class B common stock, uncertain trading volume, negative pricing pressure on the price of our Class B common stock and an adverse impact on your ability to sell any Class B common stock that you may purchase;
- the high concentration of the ownership of our Class B common stock by a limited number of affiliated stockholders;
- overall performance of the equity markets and/or publicly-listed technology companies;
- actual or anticipated fluctuations in our financial condition and results of operations and other non-GAAP metrics;
- our actual or anticipated operating performance and the operating performance of our competitors;
- changes in the projected operational and financial results we provide to the public or our failure to meet those projections;
- addition or loss of significant accounts;
- changes in laws or regulations applicable to our software solutions or business;
- actual or anticipated changes in our growth rate relative to our competitors;
- announcements of technological innovations or new offerings by us or our competitors;
- announcements by us or our competitors of significant acquisitions, strategic partnerships, joint ventures or capital-raising activities or commitments;
- any major change in our board of directors, management, or key personnel, including Barry J. Bentley, Gregory S. Bentley, Keith A. Bentley or Raymond B. Bentley in particular;
- changes in our financial guidance or securities analysts’ estimates of our financial performance, or our failure to meet the estimates or the expectations of investors;
- rumors and market speculation involving us or other companies in our industry;
- discussion of us or our stock price by the financial press and in online investor communities;
- changes in accounting principles;
- announcements related to litigation;
- fluctuations in the valuation of companies perceived by investors to be comparable to us;
- sales or expected sales of our Class B common stock by us, and our officers, directors, and principal stockholders;
- share price and volume fluctuations attributable to inconsistent trading volume levels of our shares;
- the expiration of any contractual lock-up periods;
- general economic, political, industry and market conditions, including the impending presidential election in the United States in 2020;
- new laws or regulations or new interpretations of existing laws or regulations applicable to our business, including those related to data privacy and cyber security in the United States or globally; and
- other events or factors, including those resulting from war, incidents of terrorism, pandemics, or responses to these events.

Furthermore, the stock markets recently have experienced extreme price and volume fluctuations that have affected and continue to affect the market prices of equity securities of many companies, and technology companies in particular. These fluctuations often have been unrelated or disproportionate to the operating performance of those companies. These broad market and industry fluctuations, as well as general economic, political and market conditions such as recessions, interest rate changes or international currency fluctuations, may negatively impact the market price of our Class B common stock. If the market price of our Class B common stock after this offering does not exceed the initial public offering price, you may not realize any return on your investment in us and may lose some or all of your investment. In the past, companies that have experienced volatility in the market price of their stock have been subject to securities class action litigation. We may be the target of this type of litigation in the future. Securities litigation against us could result in substantial costs and divert our management's attention from other business concerns, which could harm our business.

***There has been no public market for our Class B common stock prior to this offering, and you may not be able to resell our shares at or above the price you paid, or at all. In addition, the limited public float of our Class B common stock following this offering could adversely impact the trading price of our Class B common stock.***

Prior to this offering, there has been no public market for our capital stock. Our Class B common stock has been approved for listing on The Nasdaq Global Select Market. However, we can give no assurances that The Nasdaq Global Select Market will grant our application for listing. If an active trading market for our Class B common stock does not develop after this offering, the market price and liquidity of our common stock will be materially and adversely affected. The initial public offering price for our Class B common stock will be determined by negotiations between us and the underwriters and may bear no relationship to the market price for our Class B common stock after this offering. The market price of our Class B common stock may decline below the initial public offering price.

In addition, the number of shares of our Class B common stock sold in this offering is relatively small compared to the total number of our outstanding shares of common stock, which will result in a limited number of shares of our Class B common stock publicly owned and available for trading, or a limited "public float." The limited "public float" of our Class B common stock following this offering could result in a limited number of shares that are available to be traded at any given time, thereby adversely impacting the liquidity, trading volume and trading price of our Class B common stock. These factors could have an adverse impact on your ability to sell any Class B common stock that you may purchase.

Further, one or more funds affiliated with Capital Research Global Investors have indicated an interest in purchasing up to an aggregate of \$40 million in shares of our Class B common stock being offered by the selling stockholders in this offering at the initial public offering price. As this indication of interest is not a binding agreement or commitment to purchase, one or more funds affiliated with Capital Research Global Investors may determine to purchase more, fewer or no shares in this offering or the underwriters may determine to sell more, fewer or no shares to one or more funds affiliated with Capital Research Global Investors. The underwriters will receive the same discount from any shares of Class B common stock purchased by one or more funds affiliated with Capital Research Global Investors as they will from any other shares of Class B common stock sold to the public in this offering. If one or more funds affiliated with Capital Research Global Investors are allocated all or a portion of the shares in which it has indicated an interest in this offering, and purchase any such shares, such purchase could further reduce the available "public float" of our Class B common stock if such entities hold these shares long term.

Following the completion of this offering, we intend to evaluate opportunities to undertake a primary offering of shares of our Class B common stock by the Company, subject to the lock-up agreement entered into with the underwriters in this offering, prevailing market conditions and applicable securities laws. We have not engaged in any formal discussions regarding any such offering and we have not undertaken any steps to pursue such an offering. There is no guarantee that we will undertake such an offering or that such an offering will be consummated within the anticipated timeframe. If we do not, or are otherwise unable to, complete such an offering, the continued limited public float for our Class B common stock could result in negative pricing pressure on, and increase volatility of, the trading price for our Class B common stock. In addition, if we issue shares of capital stock in a public offering following this offering, Siemens has the right to purchase, for the price per share used in such public offering, additional shares as are necessary so

that Siemens' percentage ownership on a fully diluted basis at the time of such public offering, is unchanged as a result of such public offering. See "Certain Relationships and Related Party Transactions — Our Relationship with Siemens AG — Common Stock Purchase Agreement — Rights in a Public Offering."

***If securities or industry analysts do not publish or cease publishing research or reports about us, our business or our market, or if they change their recommendations regarding our stock adversely, or if our actual results differ significantly from our guidance, our stock price and trading volume could decline.***

The trading market for our Class B common stock will depend in part on the research and reports that securities or industry analysts publish about us or our business. If few securities analysts commence coverage of us, or if industry analysts cease coverage of us, the trading price for our Class B common stock could be negatively affected. If one or more of the analysts who cover us downgrade our Class B common stock or publish inaccurate or unfavorable research about our business, the price of our Class B common stock would likely decline. If one or more of these analysts cease coverage of us or fail to publish reports on us regularly, demand for our Class B common stock could decrease, which might cause our Class B common stock price and trading volume to decline.

***Although we have paid dividends in periods preceding this offering, there can be no assurance that we will pay dividends on our Class B common stock in the future. As a result, any return on investment may be limited to the value of our Class B common stock.***

In 2019, we paid quarterly dividends of \$0.025 per share of common stock, and in the first two quarters of 2020, we paid quarterly dividends of \$0.03 per share of common stock. While we intend to continue paying quarterly dividends following the consummation of this offering, there can be no assurance that we will pay such dividends in the amounts described herein or at all in the future. Any determination to pay dividends in the future will be at the discretion of our board of directors. The payment of dividends on our Class B common stock is restricted by Delaware law and the agreement governing the Credit Facility, and will, in all cases, depend on our earnings, financial condition, and other business and economic factors as our board of directors may consider relevant. If we do not pay dividends in future periods, our Class B common stock may be less valuable to you as an investor and investors must rely on sales of their Class B common stock after price appreciation, which may never occur, as the only way to realize any future gains on their investments. See the section titled "Dividend Policy" for more information.

***Substantial blocks of our total outstanding shares may be sold into the market when the lock-up period ends. If there are substantial sales of shares of our Class B common stock, the price of our Class B common stock could decline.***

The price of our Class B common stock could decline if there are substantial sales of our Class B common stock, particularly sales by our directors, executive officers, the selling stockholders, and other significant stockholders, if there is a perception that sales might occur or if there is a large number of shares of our Class B common stock available for sale. After this offering and after giving effect to 994,912 total shares of restricted Class B common stock and restricted stock units issued in July 2020 that will vest automatically upon the consummation of this offering, reduced by 32,238 of such restricted stock units that will be settled in cash, 1,025,461 shares of Class B common stock to be sold in this offering following the exercise of stock options for such shares and 37,237 vested shares of restricted Class B common stock and restricted stock units issued in July 2020, we will have outstanding 249,632,970 shares of our Class B common stock and 11,601,757 shares of our Class A common stock based on shares outstanding as of June 30, 2020. All of the shares of Class B common stock sold in this offering will be freely tradeable without restrictions or further registration under the Securities Act, except for any shares held by our affiliates as defined in Rule 144 under the Securities Act. A substantial portion of our shares of Class B common stock and Class A common stock, other than shares of Class B common stock issued in this offering, are subject to restrictions on resale because our directors, officers, the selling stockholders, and certain other stockholders have entered into lock-up agreements with the representatives of the underwriters. These shares will become available to be sold 181 days after the date of this prospectus, with earlier sales permitted at the discretion of Goldman Sachs. The lock-up restrictions in the lock-up agreements are more fully described in the sections titled "Shares Eligible for Future Sale" and "Underwriting." Shares held by directors, executive officers, and other affiliates will be subject to volume limitations under Rule 144 under the Securities

Act. In addition, as of the date of this prospectus, we had options outstanding for 14,504,723 shares that are not being sold in this offering that, if fully exercised, would result in the issuance of shares of Class B common stock. The shares of Class B common stock subject to outstanding options under our equity incentive plans and the shares reserved for future issuance under our equity incentive plans may become eligible for sale to the public, subject to certain legal and contractual limitations. The market price of the shares of our Class B common stock could decline as a result of the sale of a substantial number of our shares of common stock in the public market or the perception in the market that the holders of a large number of shares intend to sell their shares.

***The dual class structure of our common stock has the effect of concentrating voting control with the Bentley Control Group.***

Upon the completion of this offering, our Class A common stock will have 29 votes per share, and our Class B common stock, which is the stock we are selling in this offering, will have one vote per share. The beneficial owners of our Class A common stock will together hold approximately 57.4% of the voting power of our outstanding capital stock following this offering. Moreover, as a result of the 29 to one voting ratio between our Class A and Class B common stock, the Bentley Control Group will control a majority of the combined voting power of our common stock and therefore be able to control all matters submitted to our stockholders for approval, subject to the occurrence of certain events that would reduce the voting power of our Class A common stock or cause the conversion thereof. See the section titled “Description of Capital Stock.” This concentrated control will limit or preclude your ability to influence corporate matters for the foreseeable future and may have the effect of delaying, deferring or preventing a change in control, impeding a merger, consolidation, takeover or other business combination involving us, or discouraging a potential acquirer from making a tender offer or otherwise attempting to obtain control of our business, even if such a transaction would benefit other stockholders. The Bentley Control Group may also have interests that differ from yours and may vote in a way with which you disagree and which may be adverse to your interests. Furthermore, upon the consummation of this offering, certain members of the Bentley Control Group will be subject to a stockholders agreement, whereby the parties thereto agree to vote all their shares in an agreed upon manner. See the section titled “Certain Relationships and Related Party Transactions — Stockholders Agreement.”

In addition, we expect to be a “controlled company” for the purposes of Nasdaq Listing Rules, which will provide us with exemptions from certain of the corporate governance standards imposed by the rules of The Nasdaq Global Select Market. These provisions will further allow the Bentley Control Group to exercise significant control over our corporate decisions and limit the ability of the public stockholders to influence our decision making. See “— We will be a ‘controlled company’ within the meaning of the Nasdaq Listing Rules and, as a result, will be exempt from certain corporate governance requirements.”

Future transfers by holders of Class A common stock will generally result in those shares converting to Class B common stock, subject to limited exceptions, including certain transfers to family members and transfers effected for estate planning purposes. The conversion of Class A common stock to Class B common stock will have the effect, over time, of increasing the relative voting power of those holders of Class A common stock who retain their shares in the long term. As directors and executive officers, Barry J. Bentley, Gregory S. Bentley, Keith A. Bentley and Raymond B. Bentley owe a fiduciary duty to our stockholders and must act in good faith in a manner they reasonably believe to be in the best interests of our stockholders. As stockholders, however, each of Barry J. Bentley, Gregory S. Bentley, Keith A. Bentley and Raymond B. Bentley is entitled to vote his shares in his own interests, which may not always be in the interests of our stockholders generally. For a description of the dual class structure, see the section titled “Description of Capital Stock.”

In addition, while we do not expect to issue any additional shares of Class A common stock following this offering, any future issuances of Class A common stock would be dilutive to holders of Class B common stock.

***We cannot guarantee that Siemens will not pursue contractual claims challenging the voting power of our Class A common stock.***

The Common Stock Purchase Agreement with Siemens provides that upon our initial public offering, our certificate of incorporation shall reflect a voting structure consistent with that described in a previously

contemplated offering, immediately prior to which we would have had 11,601,757 shares of Class A common stock, each with 15 votes, and 108,308,714 shares of Class B common stock, each with one vote. The Common Stock Purchase Agreement provides that we will not deviate from such structure in any manner adverse to Siemens in any material respect in its capacity as a holder of our Class B common stock without Siemens' prior written consent, which may not be unreasonably withheld, conditioned or delayed. On May 1, 2018, we paid a dividend to all stockholders that had the economic effect of a 2-for-1 stock split, in which one share of Class B common stock was issued in respect of each outstanding share of our Class A common stock and Class B common stock (the "Split"). The Split did not impact the number of outstanding shares of Class A common stock, but increased the number of outstanding shares of Class B common stock to two times the number of pre-Split Class B shares plus the number of outstanding shares of Class A common stock. As a result and in connection with this offering where the Class B shares will first obtain voting power, we determined it was necessary to make a corresponding adjustment to the voting power of Class A common stock to 29 votes per share in order to preserve the voting structure contemplated by the Common Stock Purchase Agreement and avoid dilution of the voting power of the Class A common stock. Siemens has asserted that the Class A common stock should have 15 votes per share, notwithstanding the impact of the Split on our capital structure and the fact that this would result in a significant decrease, solely as a result of the Split, in the voting power of the holders of our Class A common stock contemplated in the Common Stock Purchase Agreement. We believe the adjustment of the voting ratio is consistent with the terms of the Common Stock Purchase Agreement, and that Siemens' assertions are without merit; however, any claims or proceedings that Siemens may bring against us, regardless of whether meritorious, could be time consuming, may result in costly litigation, the outcome of which is uncertain, and could require significant amounts of management time, result in the diversion of significant resources, any of which could harm our business, financial condition, and results of operations

***We cannot predict the effect our dual class structure may have on the market price of our Class B common stock.***

We cannot predict whether our dual class structure will result in a lower or more volatile market price of our Class B common stock, in adverse publicity, or other adverse consequences. For example, certain index providers have announced restrictions on including companies with multiple-class share structures in certain of their indices. In July 2017, FTSE Russell (whose indices include the Russell 2000) announced that it plans to require new constituents of its indices to have greater than 5% of the company's voting rights in the hands of public stockholders, and S&P Dow Jones announced that it will no longer admit companies with multiple-class share structures to certain of its indices. Affected indices include the S&P 500, S&P MidCap 400, and S&P SmallCap 600, which together make up the S&P Composite 1500. Also in 2017, MSCI, a leading stock index provider, opened public consultations on their treatment of no-vote and multi-class structures and temporarily barred new multi-class listings from certain of its indices; however, in October 2018, MSCI announced its decision to include equity securities "with unequal voting structures" in its indices and to launch a new index that specifically includes voting rights in its eligibility criteria. Under such announced policies, the dual class structure of our common stock would make us ineligible for inclusion in certain indices and, as a result, mutual funds, exchange-traded funds, and other investment vehicles that attempt to passively track those indices would not invest in our Class B common stock. These policies are relatively new and it is unclear what effect, if any, they will have on the valuations of publicly-traded companies excluded from such indices, but it is possible that they may depress valuations, as compared to similar companies that are included. Because of the dual class structure of our common stock, we will likely be excluded from certain indices and we cannot assure you that other stock indices will not take similar actions. Given the sustained flow of investment funds into passive strategies that seek to track certain indices, exclusion from certain stock indices would likely preclude investment by many of these funds and could make our Class B common stock less attractive to other investors. As a result, the market price of our Class B common stock could be adversely affected.

***We will be a "controlled company" within the meaning of the Nasdaq Listing Rules and, as a result, will be exempt from certain corporate governance requirements.***

Upon the completion of this offering, the Bentley Control Group will hold capital stock representing a majority of our outstanding voting power. So long as the Bentley Control Group maintains holdings of more than 50% of the voting power of our capital stock for the election of directors, we will be a "controlled

company” within the meaning of the Nasdaq Listing Rules and Nasdaq corporate governance standards. Under these standards, a listed company of which more than 50% of the voting power is held by an individual, group or another company is a “controlled company” and may elect not to comply with certain Nasdaq corporate governance requirements, including:

- the requirement that a majority of our board of directors consist of “independent directors” as defined under Nasdaq rules;
- the requirement that we have a compensation committee that is composed entirely of independent directors with a written charter addressing the committee’s purpose and responsibilities; and
- the requirement that we have a nominating and corporate governance committee that is composed entirely of independent directors with a written charter addressing the committee’s purpose and responsibilities, or otherwise have director nominees selected by vote of a majority of the independent directors.

We intend to use these exemptions following this offering. As a result, we will not have a majority of independent directors on our board of directors. Additionally, following this offering, we do not intend to have a compensation committee, nor do we intend to have a nominating and corporate governance committee or an independent nominating function. Instead, our full board of directors will be directly responsible for reviewing and approving compensation and benefit arrangements for our executive officers and directors, as well as for nominating members of our board.

Even as a controlled company, we will remain subject to the rules of Sarbanes-Oxley as well as the rules of the Nasdaq Listing Rules that require us to have an audit committee composed entirely of independent directors, subject to permitted phase-in rules. Under these phase-in rules, we are required to have one independent audit committee member upon the listing date of our Class B common stock, a majority of independent audit committee members within 90 days from the listing date and all independent audit committee members within one year from the listing date. Upon our listing, we expect that our audit committee will be comprised of three members, two of whom will be independent.

If we are no longer eligible to rely on the “controlled company” exceptions, we will need to comply with all applicable Nasdaq corporate governance requirements, but we will be able to rely on phase-in periods for certain of these requirements in accordance with the Nasdaq Listing Rules. Accordingly, our stockholders may not have the same protections afforded to stockholders of companies that are subject to all Nasdaq corporate governance requirements.

***Anti-takeover provisions in our charter documents and under Delaware law could make an acquisition of us more difficult, limit attempts by our stockholders to replace or remove our current management and may negatively affect the market price of our Class B common stock.***

Provisions in our amended and restated certificate of incorporation and amended and restated by-laws may have the effect of delaying or preventing a change of control or changes in our management. Our amended and restated certificate of incorporation and amended and restated by-laws include provisions that:

- provide that vacancies on our board of directors may be filled by a majority of directors then in office, even though less than a quorum;
- require that after such time as the Bentley Family no longer possess a majority of our outstanding voting power, any action to be taken by our stockholders be effected at a duly called annual or special meeting and not by written consent;
- specify that special meetings of our stockholders can be called only by our board of directors, the chairman of our board of directors or our chief executive officer or president (in the absence of a chief executive officer);
- establish an advance notice procedure for stockholder proposals to be brought before an annual meeting, including proposed nominations of persons for election to our board of directors;
- authorize our board of directors to issue, without further action by the stockholders, shares of undesignated preferred stock; and

- authorize two classes of common stock, as discussed in the section titled “Description of Capital Stock.”

These provisions may frustrate or prevent any attempts by our stockholders to replace or remove our current management by making it more difficult for stockholders to replace members of our board of directors, which is responsible for appointing the members of our management. In addition, we intend to opt out of Section 203 of the Delaware General Corporation Law (the “DGCL”), which generally prohibits a Delaware corporation from engaging in any of a broad range of business combinations with a stockholder owning 15% or more of our outstanding voting stock, unless the stockholder has held the stock for a period of at least three years or, among other things, the board of directors has approved the transaction that resulted in the stockholder owning 15% or more of our outstanding voting stock. However, our amended and restated certificate of incorporation will provide that, subject to certain exceptions (including with respect to certain transactions with the Bentley Family), we will not be able to engage in a “business combination” with any “interested stockholder” for three years following the date that the person became an interested stockholder, unless the interested stockholder attained such status with the approval of our board of directors or unless the business combination is approved in prescribed manner. See the section titled “Description of Capital Stock — Anti-Takeover Provisions.”

***The choice of forum provision in our amended and restated certificate of incorporation could limit our stockholders’ ability to obtain a favorable judicial forum for disputes with us or our directors, officers or colleagues.***

Our amended and restated certificate of incorporation provides that, to the fullest extent permitted by law, the Court of Chancery of the State of Delaware is the sole and exclusive forum for any derivative action or proceeding brought on our behalf, any action asserting a claim of a breach of fiduciary duty owed by any of our directors or officers, any action asserting a claim against us arising pursuant to the DGCL, our amended and restated certificate of incorporation or amended and restated by laws, or any action seeking to interpret, apply, enforce or determine the validity of our amended and restated certificate of incorporation or amended and restated by-laws, and any action asserting a claim against us that is governed by the internal affairs doctrine. In addition, the choice of forum provision provides that, to the extent permitted by applicable law, claims brought under the Securities Act or the Exchange Act must be brought exclusively in the federal district court for the District of Delaware. Despite the choice of forum provision, investors cannot waive compliance with federal securities laws and rules and regulations thereunder. The choice of forum provision may limit a stockholder’s ability to bring a claim in a judicial forum that it finds favorable for disputes with us or our directors, officers or other colleagues, which may discourage such lawsuits against us and our directors, officers and other colleagues. Alternatively, if a court were to find the choice of forum provision contained in our amended and restated certificate of incorporation to be inapplicable or unenforceable in an action, we may incur additional costs associated with resolving such action in other jurisdictions, which could adversely affect our business and financial condition.

***Future sales and issuances of our capital stock or rights to purchase capital stock could result in dilution of the percentage ownership of our stockholders and could cause our stock price to decline.***

We may issue additional securities following the completion of this offering. Upon the completion of this offering, our amended and restated certificate of incorporation will authorize us to issue up to 1,800,000,000 shares of Class B common stock and up to 100,000,000 shares of preferred stock. Future sales and issuances of our capital stock or rights to purchase our capital stock could result in substantial dilution to our existing stockholders. We may sell Class B common stock, preferred stock, convertible securities, and other equity securities in one or more transactions at prices and in a manner as we may determine from time to time. If we sell any such securities in subsequent transactions, investors may be materially diluted and the per share value of our Class B common stock could decline. New investors in subsequent transactions could gain rights, preferences, and privileges senior to those of holders of our Class B common stock.

***We will incur significantly increased costs and devote substantial management time as a result of operating as a public company.***

As a public company, we will incur significant legal, accounting, and other expenses that we did not incur as a private company. For example, we will be subject to the reporting requirements of the Exchange

Act, and will be required to comply with the applicable requirements of the Sarbanes-Oxley Act and the Dodd-Frank Act, as well as rules and regulations subsequently implemented by the SEC and the Nasdaq, including the establishment and maintenance of effective disclosure and financial controls and changes in corporate governance practices. We expect that compliance with these requirements will increase our legal and financial compliance costs and will make some activities more time consuming and costly. The Exchange Act requires, among other things, that we file annual, quarterly and current reports with respect to our business and results of operations. We expect to incur significant expenses and devote substantial management effort toward ensuring compliance with the auditor attestation requirements of Section 404 of the Sarbanes-Oxley Act, which will increase when we are no longer an “emerging growth company,” as defined by the JOBS Act. We may need to hire additional accounting and financial staff with appropriate public company experience and technical accounting knowledge. We cannot predict or estimate the amount of additional costs we may incur as a result of becoming a public company or the timing of such costs. As a result, management’s attention may be diverted from other business concerns, which could adversely affect our business and results of operations.

In addition, changing laws, regulations and standards relating to corporate governance and public disclosure are creating uncertainty for public companies, increasing legal and financial compliance costs and making some activities more time consuming. These laws, regulations and standards are subject to varying interpretations, in many cases due to their lack of specificity, and as a result, their application in practice may evolve over time as regulatory and governing bodies provide new guidance. These factors could result in continuing uncertainty regarding compliance matters and higher costs necessitated by ongoing revisions to disclosure and governance practices. We will continue to invest resources to comply with evolving laws, regulations and standards, and this investment may result in increased general and administrative expenses and a diversion of management’s time and attention from revenue-generating activities to compliance activities. If our efforts to comply with new laws, regulations and standards differ from the activities intended by regulatory or governing bodies due to ambiguities related to their application and practice, regulatory authorities may initiate legal proceedings against us, and our business could be adversely affected.

As a result of disclosure of information as a public company, our business and financial condition have become more visible, which may result in threatened or actual litigation, including by competitors and other third parties. If the claims are successful, our business operations and financial results could be adversely affected, and even if the claims do not result in litigation or are resolved in our favor, these claims, and the time and resources necessary to resolve them, could divert the resources of our management and adversely affect our business operations and financial results. These factors could also make it more difficult for us to attract and retain qualified colleagues, executive officers and members of our board of directors.

We also expect that operating as a public company will make it more difficult and more expensive for us to obtain director and officer liability insurance on the terms that we would like. As a result, it may be more difficult for us to attract and retain qualified people to serve on our board of directors, our board committees or as executive officers.

***Our internal control over financial reporting does not currently meet the standards required by Section 404 of the Sarbanes-Oxley Act, and failure to achieve and maintain effective internal control over financial reporting in accordance with Section 404 of the Sarbanes-Oxley Act could harm our business and stock price.***

As a privately held company, we have not been required to maintain internal control over financial reporting in a manner that meets the standards of publicly traded companies as required by Section 404(a) of the Sarbanes-Oxley Act (“Section 404(a)"). As a public company, we will be required to provide an annual management report on the effectiveness of our internal control over financial reporting commencing with our second annual report on Form 10-K. Additionally, once we are no longer an “emerging growth company,” our independent registered public accounting firm will be required to attest to the effectiveness of our internal control over financial reporting on an annual basis. The rules governing the standards that must be met for our management to assess our internal control over financial reporting are complex and require significant documentation, testing and possible remediation.

Internal control over financial reporting is a process designed to provide reasonable assurance regarding the reliability of financial reporting and the preparation of financial statements in accordance with U.S. GAAP. We are currently in the process of reviewing, documenting and testing our internal control over



financial reporting, but we are not currently in compliance with, and we cannot be certain when we will be able to implement the requirements of, Section 404(a). We may encounter problems or delays in implementing any changes necessary to make a favorable assessment of our internal control over financial reporting. In addition, we may encounter problems or delays in completing the implementation of any requested improvements and receiving a favorable attestation in connection with the attestation provided by our independent registered public accounting firm. If we cannot favorably assess the effectiveness of our internal control over financial reporting, or if our independent registered public accounting firm is unable to provide an unqualified attestation report on our internal controls, investors could lose confidence in our financial information and the price of our Class B common stock could decline.

Our independent registered public accounting firm is not required to formally attest to the effectiveness of our internal control over financial reporting until after we are no longer an “emerging growth company” as defined in the JOBS Act. At such time, our independent registered public accounting firm may issue a report that is adverse in the event it is not satisfied with the level at which our internal control over financial reporting is documented, designed or operating. Any failure to maintain effective disclosure controls and internal control over financial reporting could harm our business, financial condition, and results of operations, and could cause a decline in the price of our Class B common stock.

### CAUTIONARY NOTE REGARDING FORWARD-LOOKING STATEMENTS

This prospectus includes forward-looking statements. All statements contained in this prospectus other than statements of historical facts, including statements regarding our future results of operations and financial position, our business strategy and plans and our objectives for future operations, are forward-looking statements. The words “believe,” “may,” “will,” “estimate,” “continue,” “anticipate,” “intend,” “expect” and similar expressions are intended to identify forward-looking statements. We have based these forward-looking statements largely on our current expectations, projections and assumptions about future events and financial trends that we believe may affect our financial condition, results of operations, business strategy, short-term and long-term business operations and objectives, and financial needs. These forward-looking statements are subject to a number of risks, uncertainties and assumptions, including those described in the section titled “Risk Factors.” Moreover, we operate in a very competitive and rapidly changing environment. New risks emerge from time to time. It is not possible for our management to predict all risks, nor can we assess the impact of all factors on our business or the extent to which any factor, or combination of factors, may cause actual results to differ materially from those contained in any forward-looking statements we may make. In light of these risks, uncertainties and assumptions, the future events and trends discussed in this prospectus may not occur and actual results could differ materially and adversely from those anticipated or implied in the forward-looking statements. The forward-looking statements, as well as our prospects as a whole, are subject to risks and uncertainties, including the following:

- general global market, political, economic and business conditions;
- impact of changes in our business model and revenue streams;
- our sensitivity to changes in foreign exchange rates and interest rates and the success of our foreign currency hedging program;
- plans for future software solutions and services and for enhancements of existing software solutions and services;
- our ability to protect our intellectual property;
- the possibility that we may fail to fully comply with data protection and privacy laws;
- the possibility that we may fail to accurately estimate future revenues and profitability;
- the possibility that we may fail to accurately estimate future expenses, including research and development, sales and marketing and general and administrative expenses;
- the ability of governments in jurisdictions where we do business to meet their financial and debt obligations and finance infrastructure projects;
- the impact of the recent global coronavirus outbreak;
- our use of net proceeds from this offering;
- the possibility that we may fail to accurately estimate our capital requirements and our needs for additional financing;
- attracting and retaining accounts and colleagues;
- delayed or ineffective implementation or upgrades;
- rapid technological changes in our industry and relevant markets;
- sources of revenues and anticipated revenues;
- the impact of sanctions and export control laws on our ability to operate in certain geographical locations;
- the impact of changes in existing tax laws;
- the impact of the phase-out of LIBOR;
- the impact of changes in accounting standards;
- our ability to complete future acquisitions and difficulties encountered in integrating acquisitions;

- competition in our market;
- the sufficiency of our cash, cash equivalents, and investments to meet our liquidity needs;
- the impact of a limited “public float” on the liquidity and price of our Class B common stock;
- our ability to successfully defend litigation brought against us; and
- the increased expenses associated with being a public company.

These statements are only current predictions and are subject to known and unknown risks, uncertainties and other factors that may cause our or our industry’s actual results, levels of activity, performance or achievements to be materially different from those anticipated by the forward-looking statements. We discuss many of these risks in this prospectus in greater detail in the section titled “Risk Factors” and elsewhere in this prospectus. You should not rely upon forward-looking statements as predictions of future events.

Although we believe that the expectations reflected in the forward-looking statements are reasonable, we cannot guarantee future results, levels of activity, performance, achievements, events, or circumstances reflected in the forward-looking statements will occur. Except as required by law, we undertake no obligation to update any of these forward-looking statements after the date of this prospectus to conform these statements to actual results or revised expectations.

**MARKET AND INDUSTRY DATA**

We obtained the industry, market and competitive position data contained throughout this prospectus from our own internal estimates and research as well as from industry publications and studies conducted by third parties. This information involves a number of assumptions and limitations, and you are cautioned not to give undue weight to these estimates. The industry publications and third-party studies generally state that the information that they contain has been obtained from sources believed to be reliable, although they do not guarantee the accuracy or completeness of such information. While we believe that these publications and third-party studies and our internal data are reliable as of their respective dates, the industry in which we operate is subject to a high degree of uncertainty and risk due to a variety of factors, including those described in the section titled “Risk Factors.” These and other factors could cause results to differ materially from those expressed in these publications.

The source of certain statistical data, estimates and forecasts contained in this prospectus are the following independent industry publications or reports:

- a report prepared by Oxford Economics;
- market analyses performed by ARC Advisory Group; and
- an independent market study conducted by Cambashi, which was commissioned by us. Cambashi has consented to the references to its study and the use of its name in this prospectus and publicly-available reports.

**USE OF PROCEEDS**

The selling stockholders will receive all of the proceeds from the sale of shares of our Class B common stock in this offering. We will not receive any proceeds from the sale of shares by the selling stockholders. The selling stockholders will not be responsible for any offering expenses.

**DIVIDEND POLICY**

The declaration and payment of dividends is within the discretion of our board of directors. We paid quarterly dividends of \$0.02 per share of common stock in 2018, quarterly dividends of \$0.025 per share of common stock in 2019, and quarterly dividends of \$0.03 per share of common stock in the first three quarters of 2020. In addition, we paid the Special Dividend of \$1.50 per share of common stock on September 2, 2020. While we intend to continue paying quarterly dividends, any future determination will be subject to the discretion of our board of directors and will be dependent on a number of factors, including our results of operations, capital requirements, restrictions under Delaware law, and overall financial condition, as well as any other factors our board of directors considers relevant. In addition, the terms of the agreement governing the Credit Facility limit the amount of dividends we can pay. See the section titled “Management’s Discussion and Analysis of Financial Conditions and Results of Operations — Liquidity and Capital Resources” for a summary of the material terms of the agreement governing the Credit Facility.

## CAPITALIZATION

The following table sets forth our cash and cash equivalents and capitalization as of June 30, 2020 on:

- an actual basis;
- a pro forma basis to give effect to (i) the payment of the Special Dividend and the funding of such Special Dividend with borrowings under the New Term Loan and under the revolving facility under the Credit Facility and (ii) the accrual of the Special Dividend on 2,204,572 shares of outstanding restricted stock and restricted stock units; and
- a pro forma as adjusted basis to give effect to the Special Dividend and the funding of such Special Dividend as described in the immediately preceding bullet and to further (i) give effect to (A) 994,912 total shares of restricted Class B common stock and restricted stock units issued in July 2020 that will vest automatically upon the consummation of this offering, reduced by 32,238 of such restricted stock units that will be settled in cash, (B) approximately \$11.7 million in additional stock-based compensation expense, net of tax, in connection with such July 2020 grant (excluding restricted stock units that will settle in cash), (C) 1,025,461 shares of Class B common stock being sold in this offering following the exercise of stock options for such shares, at a weighted average exercise price of \$4.46, after giving effect to a \$1.50 reduction of the exercise price of all outstanding options as a result of the Special Dividend, as if such exercise had occurred on June 30, 2020 and (D) approximately \$0.5 million in additional stock-based compensation expense, net of tax, in connection with 37,237 vested shares of restricted Class B common stock and restricted stock units issued in July 2020, (ii) reflect expenses of \$20.8 million, net of tax, in connection with this offering by the Company, including those paid on behalf of the selling stockholders and the underwriting discounts and commissions based on the initial public offering price of the Class B common stock of \$22.00 per share, and (iii) reflect the payment in cash of the Special Dividend on 994,912 shares of outstanding restricted stock and restricted stock units that vest automatically upon the consummation of this offering, using additional borrowings under the revolving facility under the Credit Facility.

You should read this table together with the section titled “Management’s Discussion and Analysis of Financial Condition and Results of Operations” and our consolidated financial statements and related notes included elsewhere in this prospectus.

Except as otherwise indicated, all information in this prospectus assumes the filing and effectiveness of our Charter Amendments.

(in thousands, except share and per share data)	As of June 30, 2020		
	Actual	Pro forma	Pro forma as adjusted
Cash and cash equivalents <sup>(1)</sup>	\$125,516	\$ 125,516	\$ 109,788
Long-term debt	\$207,000	\$ 596,583	\$ 598,075
Stockholders’ equity (deficit):			
Class A common stock, \$0.01 par value per share; 320,000,000 shares authorized, 11,601,757 shares issued and outstanding, actual and pro forma; 100,000,000 shares authorized, 11,601,757 shares issued and outstanding, pro forma as adjusted	116	116	116
Class B common stock, \$0.01 par value per share; 600,000,000 shares authorized, 247,607,598 shares issued and outstanding, actual and pro forma; 1,800,000,000 shares authorized, 249,632,970 shares issued and outstanding, pro forma as adjusted	2,476	2,476	2,496
Additional paid-in capital	415,883	415,883	435,914
Accumulated other comprehensive loss	(28,404)	(28,404)	(28,404)
Accumulated deficit <sup>(1)</sup>	(10,327)	(403,099)	(436,053)
<b>Total stockholders’ equity (deficit)</b>	<u>379,744</u>	<u>(13,028)</u>	<u>(25,931)</u>
<b>Total capitalization</b>	<u>\$586,744</u>	<u>\$ 583,555</u>	<u>\$ 572,144</u>

- 
- (1) Pro forma as adjusted amount does not include \$709 of stock-based compensation expense for 32,238 restricted stock units that will vest automatically upon the consummation of this offering and be settled in cash at the initial public offering price of \$22.00 per share.

Except as otherwise indicated, the number of outstanding shares of Class B common stock on a pro forma as adjusted basis excludes, as of June 30, 2020: (i) 13,604,723 shares of Class B common stock issuable upon exercise of stock options outstanding as of the date of this prospectus that are not being sold in this offering, at a weighted average exercise price of \$4.85 per share of Class B common stock, after giving effect to a \$1.50 reduction of the exercise price of all outstanding options as a result of the Special Dividend; (ii) 45,151 shares of Class B common stock issuable upon the settlement of fully-vested restricted stock units outstanding as of June 30, 2020; (iii) 900,000 shares of Class B common stock issuable upon exercise of stock options outstanding as of the date of this prospectus that are not being sold in this offering and were granted in connection, with an acquisition with an exercise price of \$6.81 per share and a maximum intrinsic value of \$8.88 per share; (iv) 1,311,447 shares of unvested restricted Class B common stock and restricted stock units outstanding as of the date of this prospectus that will not vest upon consummation of this offering; (v) 27,941,520 shares of Class B common stock held by colleagues and directors as phantom shares under our nonqualified deferred compensation plans as of June 30, 2020, increased by 2,764,048 shares of Class B common stock as a result of the reinvestment of dividends since such date in accordance with such plans; (vi) 25,000,000 shares reserved for issuance under our 2020 Incentive Award Plan; and (vii) 25,000,000 shares reserved for issuance under our Global ESPP.

Except as otherwise indicated, all information in this prospectus assumes:

- no exercise of the underwriters' option to purchase additional shares; and
- the filing and effectiveness of our Charter Amendments.



**SELECTED CONSOLIDATED FINANCIAL DATA**

The following tables set forth selected consolidated financial data. The selected consolidated statement of operations data for the years ended December 31, 2018 and 2019 and the consolidated balance sheet data as of December 31, 2018 and 2019 have been derived from our audited consolidated financial statements included elsewhere in this prospectus. The selected consolidated statement of operations data for the year ended December 31, 2017 has been derived from our audited consolidated financial statements not included in this prospectus, which were audited in accordance with the auditing standards of the American Institute of Certified Public Accountants rather than the auditing standards of the Public Company Accounting Oversight Board. The consolidated statements of operations data for the six months ended June 30, 2019 and 2020 and the consolidated balance sheet data as of June 30, 2020 have been derived from our unaudited consolidated financial statements included elsewhere in this prospectus. The unaudited consolidated financial statements include all adjustments, consisting of normal recurring accruals, that we consider necessary for a fair presentation of the financial position and the results of operations for these periods. You should read this selected consolidated financial data in conjunction with the section titled “Management’s Discussion and Analysis of Financial Condition and Results of Operations” and our consolidated financial statements and related notes included elsewhere in this prospectus. Our historical results are not necessarily indicative of the results to be expected in the future, and our results of operations for the six months ended June 30, 2020 are not necessarily indicative of the results that may be expected for the entire year ending December 31, 2020 or any other period.

All amounts presented in this selected consolidated financial data, except share and per share amounts, are presented in thousands. Additionally, many of the amounts and percentages have been rounded for convenience of presentation.

**Consolidated Statements of Operations Data:**

	Year Ended December 31,				Six Months Ended June 30,	
	2017	2018	2019		2019	2020
	Topic 605		Topic 605 <sup>(1)</sup>	Topic 606	Topic 606	Topic 606
<b>Revenues:</b>						
Subscriptions	\$501,098	\$ 557,421	\$ 613,925	\$ 608,300	\$ 290,147	\$ 327,837
Perpetual licenses	61,661	61,065	52,519	59,693	24,468	23,193
Subscriptions and licenses	562,759	618,486	666,444	667,993	314,615	351,030
Services	66,164	73,224	68,405	68,661	32,529	27,950
Total revenues	628,923	691,710	734,849	736,654	347,144	378,980
<b>Cost of revenues:</b>						
Cost of subscriptions and licenses	53,662	55,113	71,439	71,578	30,831	43,128
Cost of services	66,928	76,211	72,572	72,572	38,367	30,836
Total cost of revenues	120,590	131,324	144,011	144,150	69,198	73,964
Gross profit	508,333	560,386	590,838	592,504	277,946	305,016
<b>Operating expenses:</b>						
Research and development	151,194	175,032	183,552	183,552	91,861	89,353
Selling and marketing	139,259	160,635	155,274	155,294	75,168	65,727
General and administrative	87,467	89,328	97,580	97,580	46,307	52,269
Amortization of purchased intangibles	9,014	14,000	14,213	14,213	6,852	7,115
Total operating expenses	386,934	438,995	450,619	450,639	220,188	214,464
Income from operations	121,399	121,391	140,219	141,865	57,758	90,552
Interest expense, net	(10,320)	(8,765)	(8,199)	(8,199)	(4,474)	(2,516)
Other income (expense), net	(5,773)	236	(5,557)	(5,557)	(1,747)	(6,985)
Income before income taxes	105,306	112,862	126,463	128,109	51,537	81,051
Provision for income taxes	46,141	(29,250)	21,762	23,738	5,119	11,440
Equity in loss of joint venture, net of tax	—	—	1,275	1,275	—	866
Net income	\$ 59,165	142,112	103,426	103,096	46,418	68,745
Less: Net income attributable to participating securities		(4)	(8)	(8)	(12)	—
Net income per share attributable to Class A and Class B common shares		\$ 142,108	\$ 103,418	\$ 103,088	\$ 46,406	\$ 68,745
<b>Net income per share:</b>						
Basic	\$ 0.50	\$ 0.36	\$ 0.36	\$ 0.36	\$ 0.16	\$ 0.24
Diluted	\$ 0.49	\$ 0.35	\$ 0.35	\$ 0.35	\$ 0.16	\$ 0.23
Weighted average shares outstanding, basic	285,805,096	284,625,642	284,625,642	285,529,476	286,068,766	
Weighted average shares outstanding, diluted	292,624,496	293,796,707	293,796,707	293,633,255	295,595,234	

- (1) The Topic 605 amounts presented for the year ended December 31, 2019 give effect to revenue adjustments as if the adoption of Topic 606 had not occurred on January 1, 2019. For a reconciliation of the impact of adopting Topic 606 on our audited consolidated financial statements for the year ended December 31, 2019, see Note 2 to our consolidated financial statements included elsewhere in this prospectus.

**Revenue Comparison — Topic 605 versus Topic 606:**

On January 1, 2019, we adopted Topic 606, which supersedes substantially all existing revenue recognition guidance under U.S. GAAP. We adopted Topic 606 using the modified retrospective method, under which the cumulative effect of initially applying Topic 606 was recorded as a reduction to the opening balance of *Accumulated deficit* of \$125,464 (\$101,489, net of tax) as of January 1, 2019. We applied the standard only to contracts that were not completed as of the date of initial application. The comparative information in our consolidated financial statements included elsewhere in this prospectus has not been adjusted and continues to be reported under Topic 605.

The below table presents a comparison of our revenues as recognized under Topic 605 and Topic 606. We believe that an understanding of the impact of the revenue recognition guidance under Topic 606 on our revenues and revenue trends is useful in evaluating our operating performance.

	Year Ended December 31,		
	2017	2018	2019
<b>Topic 605:<sup>(1)</sup></b>			
Subscriptions	\$501,098	\$557,421	\$613,925
Perpetual licenses	61,661	61,065	52,519
Services	66,164	73,224	68,405
<b>Total Revenues</b>	<b><u>\$628,923</u></b>	<b><u>\$691,710</u></b>	<b><u>\$734,849</u></b>
<b>Topic 606:<sup>(2)</sup></b>			
Subscriptions	\$505,720	\$560,485	\$608,300
Perpetual licenses	49,983	57,353	59,693
Services	66,164	73,224	68,661
<b>Total Revenues</b>	<b><u>\$621,867</u></b>	<b><u>\$691,062</u></b>	<b><u>\$736,654</u></b>

- (1) The Topic 605 amounts presented for the year ended December 31, 2019 give effect to revenue adjustments as if the adoption of Topic 606 had not occurred on January 1, 2019. For a reconciliation of the impact of adopting Topic 606 on our audited consolidated financial statements for the year ended December 31, 2019, see Note 2 to our consolidated financial statements included elsewhere in this prospectus.
- (2) The Topic 606 unaudited amounts presented for the years ended December 31, 2017 and 2018 give effect to revenue adjustments as if the adoption of Topic 606 had occurred as of January 1, 2017 rather than January 1, 2019. For a reconciliation of the impact of adopting Topic 606 as if it had occurred as of January 1, 2017 on our audited consolidated statements of operations data for the years ended December 31, 2017 and 2018, see the section titled “— Non-GAAP Financial Measures” below.

**Key Business Metrics:**

We regularly review the following key metrics to evaluate our business, measure our performance, identify trends in our business, prepare financial projections, and make strategic decisions.

	Year Ended December 31,			Twelve Months Ended June 30,	
	2017	2018	2019	2019	2020
Last twelve-months recurring revenues (Topic 606)	\$521,923	\$586,466	\$631,097	\$606,411	\$665,659
Last twelve-months recurring revenues (Topic 605)	\$523,502	\$583,402	\$636,899	\$604,043	\$670,825
Constant Currency:					
ARR growth rate	9%	10%	12%	11%	11%
Account retention rate	98%	98%	98%	98%	98%
Recurring revenues dollar-based net retention rate	105%	107%	108%	106%	110%

**Last twelve-months recurring revenues.** Last twelve-months recurring revenues is calculated as recurring revenues recognized over the preceding twelve-month period. We define recurring revenues as subscriptions revenues that recur monthly, quarterly, or annually with specific or automatic renewal clauses and professional services revenues in which the underlying contract is based on a fixed fee and contains automatic annual renewal provisions.

Last twelve-months recurring revenues is presented using revenues recognized pursuant to Topic 606 as well as Topic 605 for all periods in order to enhance comparability during our transition to Topic 606. The Topic 606 unaudited amounts presented for the years ended December 31, 2017 and 2018 give effect to revenue adjustments as if the adoption of Topic 606 had occurred as of January 1, 2017 rather than January 1, 2019. For a reconciliation of the impact of adopting Topic 606 as if it had occurred as of January 1, 2017 on our audited consolidated statements of operations data for the years ended December 31, 2017 and 2018, see the section titled “— Non-GAAP Financial Measures.”

On an annual and trailing twelve-month basis, we expect our recurring revenues recognized under Topic 606 to be comparable to such revenues recognized under Topic 605. This expectation is attributable to the annual, recurring nature of our subscription agreements. However, the conversion of our existing subscription users to consumption-based offerings with consumption measurement durations of less than one year, such as our E365 program, as well as the term start date of new annual term license subscriptions, will introduce some volatility between annual and trailing twelve-month periods and impact period over period comparability. Specifically, in 2019, the conversion of existing ELS subscriptions to consumption-based E365 subscriptions resulted in a reduction of Topic 606 Enterprise subscriptions revenues of \$11,248 when compared to Topic 605. This impact was partly offset by higher annual term license subscriptions revenues under Topic 606 of \$5,714 due to the upfront recognition of license revenues of new subscriptions. See the section titled “Management’s Discussion and Analysis of Financial Condition and Results of Operations — Key Factors Impacting Comparability and Performance.”

We believe that last twelve-months recurring revenues is an important indicator of our performance during the immediately preceding twelve-month time period. We believe that we will continue to experience favorable growth in recurring revenues due to our strong account retention and recurring revenues dollar-based net retention rates as well as the addition of new accounts with recurring revenues. The last twelve-months recurring revenues under Topic 606 for the periods ended December 31, 2018, December 31, 2019, and June 30, 2020 compared to the last twelve-months of the preceding twelve-month period increased by \$64,543 (or \$59,900 under Topic 605), \$44,631 (or \$53,497 under Topic 605), and \$59,248 (or \$66,782 under Topic 605), respectively. These increases were primarily due to growth in ARR during the prior and current periods, which is primarily the result of consistent performance in our account retention rate and in our recurring revenues dollar-based net retention rate, as well as additional recurring revenues resulting from new accounts and acquisitions. For the twelve months ended December 31, 2019, 86% of our total

revenues under Topic 606 (or 87% under Topic 605) were recurring revenues. For the twelve months ended June 30, 2020, 87% of our revenues were recurring revenues. Prospectively, we expect that this percentage is likely to remain consistent or modestly increase as we continue to target shifting episodic professional services revenues to subscriptions classified as recurring revenues.

**Constant currency metrics.** In reporting period-over-period results, we calculate the effects of foreign currency fluctuations and constant currency information by translating current period results using prior period average foreign currency exchange rates. Our definition of constant currency may differ from other companies reporting similarly named measures, and these constant currency performance measures should be viewed in addition to, and not as a substitute for, our operating performance measures calculated in accordance with U.S. GAAP.

**ARR growth rate.** Our ARR growth rate is the growth rate of our ARR, measured on a constant currency basis. Our ARR is defined as the sum of the annualized value of our portfolio of contracts that produce recurring revenue as of the last day of the reporting period, and the annualized value of the last three months of recognized revenues for our contractually recurring consumption-based software subscriptions with consumption measurement durations of less than one year. We believe that the last three months of recognized revenues, on an annualized basis, for our recurring software subscriptions with consumption measurement period durations of less than one year is a reasonable estimate of the annual revenues, given our consistently high retention rate and stability of usage under such subscriptions. ARR resulting from the annualization of recurring contracts with consumption measurement durations of less than one year, as a percentage of total ARR was 9%, 15%, and 25% as of December 31, 2017, 2018, and 2019, respectively, and 18% and 29% as of June 30, 2019 and 2020, respectively. Within our consumption-measured ARR, the successful uptake of our new E365 subscription offering has introduced daily consumption-measured ARR, representing 16% of total ARR as of June 30, 2020.

ARR is inclusive of the ARR of acquired companies as of the date they are acquired. We believe that ARR and ARR growth are important metrics indicating the scale and growth of our business. Furthermore, we believe ARR, considered in connection with our account retention rate and our recurring revenues dollar-based net retention rate, is a leading indicator of revenue growth. Our ARR as of June 30, 2020 was \$697,682, calculated using the spot foreign exchange rates as of June 30, 2020.

There was no impact to our ARR growth rate from acquisitions for the year ended December 31, 2017. Our ARR growth rate was favorably impacted from acquisitions by 3% and 1% for the years ended December 31, 2018 and 2019, respectively, and by 1% and 2% for the twelve months ended June 30, 2019 and 2020, respectively.

**Account retention rate.** Our account retention rate for any given twelve-month period is calculated using the average currency exchange rates for the prior period, as follows: the prior period recurring revenues from all accounts with recurring revenues in the current and prior period, divided by total recurring revenues from all accounts during the prior period. The account retention rate is calculated using revenues recognized pursuant to Topic 605 for all periods in order to enhance comparability during our transition to Topic 606 as we do not have all information available to us necessary to present account retention rate pursuant to Topic 606 for any period prior to January 1, 2019. Our account retention rate is an important indicator that provides insight into the long-term value of our account relationships and our ability to retain our account base. We believe that our consistent and high account retention rates illustrate our ability to retain and cultivate long-term relationships with our accounts.

**Recurring revenues dollar-based net retention rate.** Our recurring revenues dollar-based net retention rate is calculated using the average exchange rates for the prior period, as follows: the recurring revenues for the current period, including any growth or reductions from existing accounts, but excluding recurring revenues from any new accounts added during the current period, divided by the total recurring revenues from all accounts during the prior period. A period is defined as any trailing twelve months. The recurring revenues dollar-based net retention rate is calculated using revenues recognized pursuant to Topic 605 for all periods in order to enhance comparability during our transition to Topic 606 as we do not have all information available to us necessary to present recurring revenues dollar-based net retention rate pursuant to Topic 606 for any period prior to January 1, 2019. We believe our recurring revenues dollar-based net retention rate is a key indicator of our success in growing our revenues within our existing accounts. Given

that for the twelve months ended December 31, 2019 recurring revenues represented 86% of our total revenues under Topic 606, this metric helps explain our revenue performance as primarily growth into existing accounts. We believe that our consistent and high recurring revenues dollar-based net retention rate illustrates our ability to consistently retain accounts and grow them.

As discussed above, we expect annual and trailing twelve-month recurring revenues recognized under Topic 606 to be comparable to such revenues recognized under Topic 605 due to the annual, recurring nature of our subscription agreements. We, therefore, also expect that our account retention rate and our recurring revenue dollar-based net retention rate under Topic 606 will be comparable to such metrics under Topic 605. However, under Topic 606, the conversion of our existing subscription users to consumption-based offerings with consumption measurement durations of less than one year, such as our E365 program, as well as the term start date of new subscriptions, will introduce some volatility between annual, and trailing twelve-month periods and impact period over period comparability. See the section titled “Key Factors Impacting Comparability and Performance.”

Our calculation of these metrics may not be comparable to other companies with similarly-titled metrics.

For additional information about our key metrics, see the section titled “Management’s Discussion and Analysis of Financial Condition and Results of Operations — Key Business Metrics.”

#### Non-GAAP Financial Measures:

In addition to our results determined in accordance with U.S. GAAP, we believe the below non-GAAP measures are useful in evaluating our operating performance. We use the below non-GAAP financial information, collectively, to evaluate our ongoing operations and for internal planning and forecasting purposes.

	Year Ended December 31,		
	2017	2018	2019
Topic 605: <sup>(1)</sup>			
Adjusted EBITDA	\$160,886	\$171,768	\$186,598
Adjusted Net Income	\$115,389	\$132,246	\$135,471
Topic 606: <sup>(2)</sup>			
Adjusted EBITDA	\$153,830	\$171,120	\$188,129
Adjusted Net Income	\$109,398	\$131,697	\$135,049

- (1) The Topic 605 amounts presented for the year ended December 31, 2019 give effect to revenue adjustments as if the adoption of Topic 606 had not occurred on January 1, 2019. For a reconciliation of the impact of adopting Topic 606 on our audited consolidated financial statements for the year ended December 31, 2019, see Note 2 to our consolidated financial statements included elsewhere in this prospectus.
- (2) The Topic 606 unaudited amounts presented for the years ended December 31, 2017 and 2018 give effect to revenue adjustments as if the adoption of Topic 606 had occurred as of January 1, 2017 rather than January 1, 2019.

	Six Months Ended June 30,	
	2019	2020
Topic 606:		
Adjusted EBITDA	\$79,384	\$115,506
Adjusted Net Income	\$59,978	\$ 89,203

*Adjusted EBITDA.* We define Adjusted EBITDA as net income adjusted for interest expense, net, provision for income taxes, depreciation and amortization, equity-based compensation, acquisition expenses, realignment expenses, other non-operating income and expense, net, and equity in loss of joint venture, net of tax.

*Adjusted Net Income.* We define Adjusted Net Income as net income adjusted for the following: amortization of purchased intangibles and developed technologies, equity-based compensation, acquisition expenses, realignment expenses, other non-operating income and expense, net, the tax effect of the above adjustments to net income, non-recurring income tax expense and benefit, and equity in loss of joint venture, net of tax. The tax effect of adjustments to net income is based on the estimated marginal effective tax rates in the jurisdictions impacted by such adjustments.

Adjusted EBITDA and Adjusted Net Income are not presentations made in accordance with U.S. GAAP, and our use of the terms Adjusted EBITDA and Adjusted Net Income may vary from the use of similarly titled measures by others in our industry due to the potential inconsistencies in the method of calculation and differences due to items subject to interpretation. We believe the presentation of Adjusted EBITDA and Adjusted Net Income provides useful information to management and investors regarding financial and business trends related to our results of operations and that when non-GAAP financial information is viewed with U.S. GAAP financial information, investors are provided with a more meaningful understanding of our ongoing operating performance. We also use Adjusted EBITDA and Adjusted Net Income to compare our results to those of our competitors and to consistently measure our performance from period to period.

Adjusted EBITDA and Adjusted Net Income should not be considered as alternatives to net income, operating income, or any other performance measures derived in accordance with U.S. GAAP as measures of operating performance. Adjusted EBITDA and Adjusted Net Income have important limitations as analytical tools and should not be considered in isolation or as a substitute for analysis of our results as reported under U.S. GAAP.

Reconciliation of net income to Adjusted EBITDA (Topic 605):

	<b>Year Ended December 31,</b>		
	<b>2017</b>	<b>2018</b>	<b>2019</b>
Net income <sup>(1)</sup>	\$ 59,165	\$ 142,112	\$ 103,426
Interest expense, net	10,320	8,765	8,199
Provision (benefit) for income taxes	46,141	(29,250)	21,762
Depreciation and amortization <sup>(3)(a)</sup>	26,544	29,200	32,160
Equity-based compensation <sup>(3)(c)</sup>	4,985	7,989	8,091
Acquisition expenses <sup>(3)(d)</sup>	3,020	6,410	6,712
Realignment expenses <sup>(3)(e)</sup>	4,938	6,778	(584)
Other (income) expense, net <sup>(3)(f)</sup>	5,773	(236)	5,557
Equity in loss of joint venture, net of tax	—	—	1,275
Adjusted EBITDA	<u>\$160,886</u>	<u>\$171,768</u>	<u>\$186,598</u>

## Reconciliation of net income to Adjusted Net Income (Topic 605):

	Year Ended December 31,		
	2017	2018	2019
Net income <sup>(1)</sup>	\$ 59,165	\$ 142,112	\$ 103,426
Non-GAAP adjustments, prior to income taxes:			
Amortization of purchased intangibles and developed technologies <sup>(3)(b)</sup>	13,879	17,215	18,731
Equity-based compensation <sup>(3)(c)</sup>	4,985	7,989	8,091
Acquisition expenses <sup>(3)(d)</sup>	3,020	6,410	6,712
Realignment expenses <sup>(3)(e)</sup>	4,938	6,778	(584)
Other (income) expense, net <sup>(3)(f)</sup>	5,773	(236)	5,557
Total non-GAAP adjustments, prior to income taxes	32,595	38,156	38,507
Income tax effect of non-GAAP adjustments	(6,644)	(5,971)	(7,737)
Non-recurring income tax expense related to Tax Cuts and Jobs Act <sup>(3)(g)</sup>	30,273	4,318	—
Non-recurring income tax benefit related to intercompany transactions <sup>(3)(h)</sup>	—	(46,369)	—
Equity in loss of joint venture, net of tax	—	—	1,275
Adjusted Net Income	<u>\$115,389</u>	<u>\$132,246</u>	<u>\$135,471</u>

## Reconciliation of net income to Adjusted EBITDA (Topic 606):

	Year Ended December 31,			Six Months Ended June 30,	
	2017	2018	2019	2019	2020
Net income <sup>(2)</sup>	\$ 53,174	\$ 141,563	\$ 103,096	\$ 46,418	\$ 68,745
Interest expense, net	10,320	8,765	8,199	4,474	2,516
Provision (benefit) for income taxes	45,076	(29,349)	23,738	5,119	11,440
Depreciation and amortization <sup>(3)(a)</sup>	26,544	29,200	32,160	15,366	16,664
Equity-based compensation <sup>(3)(c)</sup>	4,985	7,989	8,091	4,025	3,212
Acquisition expenses <sup>(3)(d)</sup>	3,020	6,410	6,597	2,678	5,009
Realignment expenses <sup>(3)(e)</sup>	4,938	6,778	(584)	(443)	69
Other (income) expense, net <sup>(3)(f)</sup>	5,773	(236)	5,557	1,747	6,985
Equity in loss of joint venture, net of tax	—	—	1,275	—	866
Adjusted EBITDA	<u>\$153,830</u>	<u>\$171,120</u>	<u>\$188,129</u>	<u>\$79,384</u>	<u>\$115,506</u>



## Reconciliation of net income to Adjusted Net Income (Topic 606):

	Year Ended December 31,			Six Months Ended June 30,	
	2017	2018	2019	2019	2020
Net income <sup>(2)</sup>	\$ 53,174	\$ 141,563	\$ 103,096	\$ 46,418	\$ 68,745
Non-GAAP adjustments, prior to income taxes:					
Amortization of purchased intangibles and developed technologies <sup>(3)(b)</sup>	13,879	17,215	18,731	9,061	9,458
Equity-based compensation <sup>(3)(c)</sup>	4,985	7,989	8,091	4,025	3,212
Acquisition expenses <sup>(3)(d)</sup>	3,020	6,410	6,597	2,678	5,009
Realignment expenses <sup>(3)(e)</sup>	4,938	6,778	(584)	(443)	69
Other (income) expense, net <sup>(3)(f)</sup>	5,773	(236)	5,557	1,747	6,985
Total non-GAAP adjustments, prior to income taxes	32,595	38,156	38,392	17,068	24,733
Income tax effect of non-GAAP adjustments	(6,644)	(5,971)	(7,714)	(3,508)	(5,141)
Non-recurring income tax expense related to Tax Cuts and Jobs Act <sup>(3)(g)</sup>	30,273	4,318	—	—	—
Non-recurring income tax benefit related to intercompany transactions <sup>(3)(h)</sup>	—	(46,369)	—	—	—
Equity in loss of joint venture, net of tax	—	—	1,275	—	866
Adjusted Net Income	\$ 109,398	\$ 131,697	\$ 135,049	\$ 59,978	\$ 89,203

- (1) The Topic 605 amounts presented for the year ended December 31, 2019 give effect to revenue adjustments as if the adoption of Topic 606 had not occurred on January 1, 2019. For a reconciliation of the impact of adopting Topic 606 on our audited consolidated financial statements for the year ended December 31, 2019, see Note 2 to our consolidated financial statements included elsewhere in this prospectus.
- (2) The Topic 606 unaudited amounts presented for the years ended December 31, 2017 and 2018 give effect to revenue and income tax adjustments as if the adoption of Topic 606 had occurred as of January 1, 2017 rather than January 1, 2019. The most significant impact from the adoption of Topic 606 relates to timing of revenue recognition for perpetual licenses and the accounting for certain of our subscription arrangements that include term-based software licenses bundled with support. Under prior guidance, revenue for perpetual licenses was recognized over a three-year period, while revenue attributable to the term-based software licenses was recognized ratably over the term. Under Topic 606, both perpetual license and prepaid term-based software license revenue will be recognized upfront upon delivery of the software license. Our revenue recognition for services, as well as our accounting for costs to obtain a contract with a customer, remained substantially unchanged and were not adjusted. See Note 2 to our consolidated financial statements included elsewhere in this prospectus for additional information regarding the adoption of Topic 606.

## Reconciliation of Topic 605 to Topic 606:

	Year Ended December 31, 2017		
	As reported Topic 605	Adjustments	Topic 606
Subscriptions	\$ 501,098	\$ 4,622	\$ 505,720
Perpetual licenses	61,661	(11,678)	49,983
Provision for income taxes	46,141	(1,065)	45,076
Net income	59,165	\$ (5,991)	53,174

	Year Ended December 31, 2018		
	As reported Topic 605	Adjustments	Topic 606
Subscriptions	\$ 557,421	\$ 3,064	\$560,485
Perpetual licenses	61,065	(3,712)	57,353
Provision for income taxes	(29,250)	(99)	(29,349)
Net income	142,112	<u>\$ (549)</u>	141,563

- (3) Further explanation of certain of our adjustments in arriving at Adjusted EBITDA and Adjusted Net Income are as follows:
- (a) *Depreciation and amortization.* Depreciation and amortization includes amortization of \$1,617, \$2,052, and \$3,516 for the years ended December 31, 2017, 2018, and 2019, respectively, and \$1,448 and \$2,022 for the six months ended June 30, 2019 and 2020, respectively, related to certain projects under our Accelerated Commercial Development Program (“ACDP”).
  - (b) *Amortization of purchased intangibles and developed technologies.* Amortization of purchased intangibles varies in amount and frequency and is significantly impacted by the timing and size of our acquisitions. For the years ended December 31, 2017, 2018, and 2019 and the six months ended June 30, 2019 and 2020, amortization of acquisition related developed technologies under our ACDP was \$359, \$375, \$723, \$363, and \$182, respectively. Management finds it useful to exclude these variable charges from our operating expenses to assist in budgeting, planning and forecasting future periods. The use of intangible assets and developed technologies contributed to our revenues earned during the periods presented and will also contribute to our revenues in future periods. Amortization of purchased intangible assets and developed technologies will recur in future periods.
  - (c) *Equity-based compensation.* We exclude equity-based compensation expenses from our non-GAAP measures primarily because they are non-cash expenses and management finds it useful to exclude certain non-cash charges to assess the appropriate level of various operating expenses to assist in budgeting, planning and forecasting future periods. Moreover, because of varying available valuation methodologies, subjective assumptions and the variety of award types that companies can use under ASC 718, *Compensation — Stock Compensation*, we believe excluding equity-based compensation expenses allows investors to make meaningful comparisons between our recurring core business results of operations and those of other companies.
  - (d) *Acquisition expenses.* We incur expenses for professional services rendered in connection with business combinations, which are included in our U.S. GAAP presentation of general and administrative expense. Also included in our acquisition expenses are retention incentives paid to executives of the acquired companies as well as adjustments related to deferred revenue from acquired companies. We exclude these acquisition expenses when we evaluate our continuing operational performance as we would not have otherwise incurred these expenses in the periods presented as part of our continuing operations. Acquired deferred revenue is recorded on the opening balance sheet at an amount that typically is lower than historical carrying value. The adjustment to acquired deferred revenue has no impact on our business or cash flow, but it does reduce reported U.S. GAAP revenue in the periods following an acquisition.
  - (e) *Realignment expenses.* These expenses are associated with realigning our business strategies to better serve our accounts and to better align resources with the evolving needs of the business. In connection with these actions, we recognize costs related to termination benefits for former colleagues whose positions were eliminated. We exclude these charges because they are not reflective of our ongoing business and results of operation. We believe it is useful for investors to understand the effects of these items on our total operating expenses. In the ordinary course of operating our business, we incur severance expenses that are not included in this adjustment.
  - (f) *Other (income) expense, net.* Primarily consists of foreign currency translation losses of \$6,294, \$418, and \$5,591 for the years ended December 31, 2017, 2018, and 2019, respectively, and \$1,588 and \$4,263 for the six months ended June 30, 2019 and 2020, respectively. The foreign currency translation losses derive primarily from U.S. Dollar denominated intercompany balances, cash and

cash equivalents, and accounts receivable held by foreign subsidiaries with non-U.S. Dollar functional currencies. In October 2018, we had intercompany sales of certain intangible operating assets between our foreign subsidiaries, which resulted in significant U.S. Dollar denominated intercompany liabilities at foreign subsidiaries with a non-U.S. Dollar functional currency (mainly Euro). These U.S. Dollar denominated balances are being translated into their functional currencies at the rates in effect at the balance sheet date and are fully eliminated in consolidation. The gains and losses from such translations are included in Other income (expense), net. For the year ended December 31, 2019 and the six months ended June 30, 2019 and 2020, intercompany loan balances resulted in unrealized foreign currency translation losses of \$5,270, \$1,680, and \$1,765, respectively. Foreign currency translation gain and losses are driven by the volume of foreign currency transactions and the foreign currency exchange rates for the year. A significant amount of such gains and losses is derived from the translation of intercompany balances which eliminate in consolidation and are unrealized. Other (income) expense, net also includes the loss from the change in fair value of our interest rate swap of \$4,174 for the six months ended June 30, 2020. We exclude these charges because they are not reflective of ongoing business and results of operation. We believe it is useful for investors to understand the effects of these items on our total operating expenses.

- (g) *Non-recurring income tax expense related to Tax Cuts and Jobs Act.* The U.S. Tax Cuts and Jobs Act was enacted on December 22, 2017 and resulted in a provisional tax expense of \$30,273 in 2017 primarily due to the one-time transition tax on accumulated foreign subsidiary earnings and deferred tax impacts. For the year ended December 31, 2018, we recorded a \$4,318 increase to tax expense related to provisional amounts recorded in 2017.
- (h) *Non-recurring income tax benefit related to intercompany transactions.* For the year ended December 31, 2018, we had intercompany sales of certain intangible operating assets between our foreign subsidiaries, which resulted in a non-recurring net tax benefit of \$46,369.

#### Consolidated Balance Sheet Data:

The following table presents summary consolidated balance sheet data as of December 31, 2018 and 2019 and June 30, 2020:

	December 31, 2018	December 31, 2019	June 30, 2020
Cash and cash equivalents	\$ 81,183	\$ 121,101	\$ 125,516
Working capital, excluding deferred revenues	135,163	166,136	104,275
Total assets	923,596	994,599	1,059,169
Deferred revenues, current and long-term	337,451	213,145	186,456
Total debt	258,750	233,750	207,000
Total stockholders' equity	147,431	334,619	379,744

## MANAGEMENT'S DISCUSSION AND ANALYSIS OF FINANCIAL CONDITION AND RESULTS OF OPERATIONS

*The following discussion should be read in conjunction with the section titled "Selected Consolidated Financial Data" and our consolidated financial statements and related notes thereto included elsewhere in this prospectus. In addition to historical information, this discussion contains forward-looking statements that involve risks, uncertainties and assumptions that could cause actual results to differ materially from management's expectations. Factors that could cause such differences are discussed in the sections titled "Cautionary Note Regarding Forward-Looking Statements" and "Risk Factors."*

All amounts presented in this Management's Discussion and Analysis of Financial Condition and Results of Operations, except share and per share amounts, are presented in thousands. Additionally, many of the amounts and percentages have been rounded for convenience of presentation.

### Overview:

We are a leading global provider of software for infrastructure engineering, enabling the work of civil, structural, geotechnical, and plant engineering practitioners, their project delivery enterprises, and owner-operators of infrastructure assets. We were founded in 1984 by the Bentley brothers. Our enduring commitment is to develop and support the most comprehensive portfolio of integrated software offerings across professional disciplines, project and asset lifecycles, infrastructure sectors, and geographies. Our software enables digital workflows across engineering disciplines, distributed project teams, from offices to the field, and across computing form factors, including desktops, on-premises servers, cloud-native services, mobile devices, and web browsers. We deliver our solutions via on-premise, cloud, and hybrid environments. Our users engineer, construct, and operate projects and assets across the following infrastructure sectors:

- *public works* (including roads, rail, airports, ports, and water and wastewater networks) / *utilities* (including electric, gas, water, and communications). We estimate that this sector represents 52% of the net infrastructure asset value of the global top 500 infrastructure owners (the "global top 500 infrastructure owners") based on the 2019 edition of the *Bentley Infrastructure 500 Top Owners*, our annual compilation of the world's largest infrastructure owners ranked by net depreciated value of their tangible fixed assets;
- *industrial* (including discrete and process manufacturing, power generation, and water treatment plants) / *resources* (including oil and gas, mining, and offshore). We estimate that this sector represents 38% of the global top 500 infrastructure owners' net infrastructure asset value; and
- *commercial/facilities* (including office buildings, hospitals, and campuses). We estimate that this sector represents 10% of the global top 500 infrastructure owners' net infrastructure asset value.

We offer solutions for enterprises and professionals across the infrastructure lifecycle. Our Project Delivery and Asset and Network Performance solutions are systems provided via cloud and hybrid environments, developed respectively to extend enterprise collaboration during project delivery, and to manage and leverage engineering information during operations and maintenance. Our Design Integration and Digital Cities solutions are primarily desktop applications and cloud-provisioned solutions for professional practitioners and workgroups.

We continue to make substantial investments in research and development because we believe the infrastructure engineering software market presents compelling opportunities for the application of new technologies that advance our current solutions. Our research and development roadmap balances technology advances and new offerings with continuous enhancements to existing offerings. Our allocation of research and development resources is guided by management-established priorities, input from product managers, and user and sales force feedback.

We bring our offerings to market primarily through direct sales channels that generated approximately 92% of our 2019 revenues.

Since its founding, Bentley Systems has remained focused on our mission to provide software in support of the professional needs of those responsible for creating and managing the world's infrastructure.

We have methodically grown through periods of global expansion, periods of expansion in our portfolio of solutions, and periods of rapid technological change. The following provides key corporate milestones over our 35-year history:

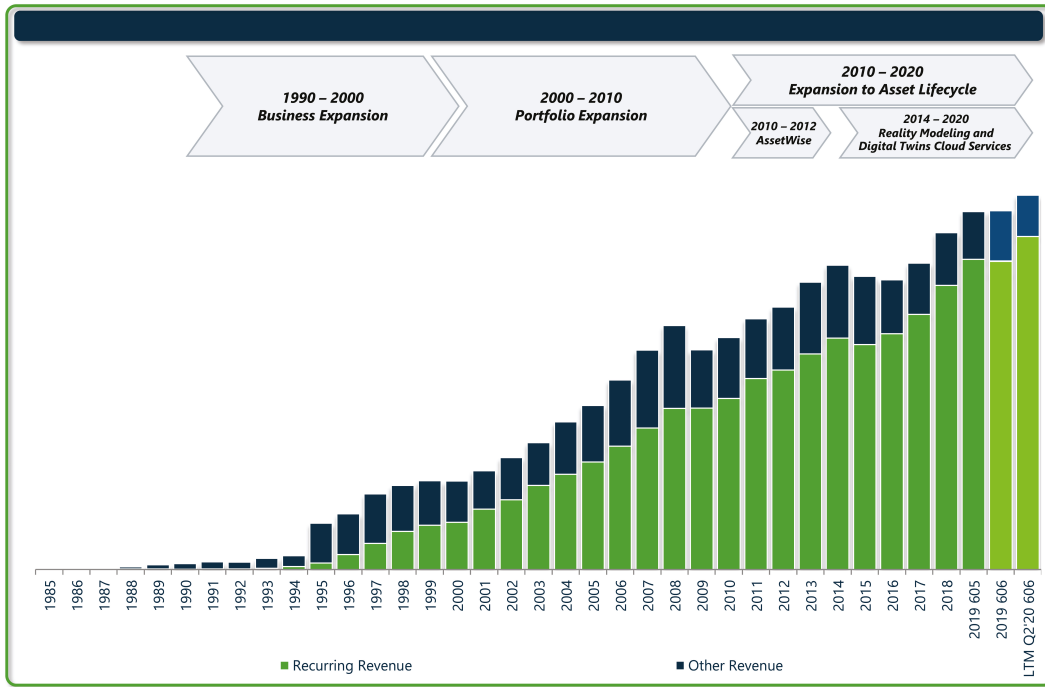

Our sources of revenue growth, in order of magnitude, come from the recurrence of existing subscription revenues, additional revenue and growth from existing accounts using the same products, additional revenue and growth from existing accounts using new products, and growth from new accounts. For the year ended December 31, 2019, under Topic 606, subscriptions represented 83% of our revenues, and together with certain professional services revenues that are recurring in nature and represented 3% of our revenues, bring the proportion of our recurring revenues to 86% of total revenues. The remaining 14% of our revenues were generated from the sale of perpetual licenses and the delivery of non-recurring professional services. We have a highly-diversified account base, with our largest account representing no more than 2.5% of total revenues in 2019. Our 2019 revenues were also diversified by account type, size, and geography. Additionally, we believe that we have a loyal account base, with 80% of our 2019 revenues from organizations that have been our accounts for over ten years. Between 2000 and 2019, our revenues had an approximately 8% compound annual growth rate.

## Our Commercial Offerings:

Our solutions are made available to our accounts in a broad range of commercial offerings designed to accommodate the diverse preferences of our accounts, which range from owned versus subscribed, short-term subscriptions versus longer term annual subscriptions, and fee-certain arrangements versus variable or consumption-based arrangements with consumption measurement durations of less than one year. We contract our commercial offerings under a single form of standard contract, which includes liability and other risk protections in our favor, and appropriate standard addendums to the primary contract, which specifically address the commercial offerings provided. Our standard commercial offerings are summarized in the below table, with further descriptions following the table:

	Subscription Offerings			Term License Subscriptions	Perpetual Licenses	Professional Services
	SELECT Subscriptions	Enterprise Subscriptions				
		E365	ELS			
<b>Overview</b>	<ul style="list-style-type: none"> <li>Prepaid annual recurring subscription based on owned perpetual licenses</li> </ul>	<ul style="list-style-type: none"> <li>Complete and unlimited global access to our comprehensive portfolio of solutions</li> <li>Includes benefits of SELECT subscriptions</li> </ul>		<ul style="list-style-type: none"> <li>Consumption-based growth and expansion</li> </ul>	<ul style="list-style-type: none"> <li>Available for accounts that prefer to own software licenses</li> </ul>	<ul style="list-style-type: none"> <li>Offered alongside all subscription and license offerings</li> </ul>
<b>Topic 606 Revenue Recognition</b>	<ul style="list-style-type: none"> <li>Substantially ratable</li> </ul>	<ul style="list-style-type: none"> <li>Quarterly</li> </ul>	<ul style="list-style-type: none"> <li>Substantially upfront</li> </ul>	<ul style="list-style-type: none"> <li>Usage based, or substantially upfront if prepaid</li> </ul>	<ul style="list-style-type: none"> <li>Upfront</li> </ul>	<ul style="list-style-type: none"> <li>As delivered</li> </ul>
<b>Key Features</b>	<ul style="list-style-type: none"> <li>Software upgrades</li> <li>Technical support</li> <li>License pooling</li> <li>CONNECTservices</li> <li>Open Access</li> <li>Portfolio Balancing</li> </ul>	<ul style="list-style-type: none"> <li>Unlimited portfolio access and users</li> <li>Global pricing</li> <li>Success Plan services included</li> </ul>	<ul style="list-style-type: none"> <li>Unlimited portfolio access; unlimited users</li> <li>License pooling</li> </ul>	<ul style="list-style-type: none"> <li>For <i>Applications</i>: unlimited portfolio access; unlimited users</li> <li>For <i>ProjectWise</i> and <i>AssetWise</i>: term access via Passports and Visas or Annual Subscriptions</li> </ul>	<ul style="list-style-type: none"> <li>License ownership for select accounts</li> </ul>	<ul style="list-style-type: none"> <li>Training</li> <li>Implementation</li> <li>Configuration</li> <li>Customization</li> <li>Strategic consulting</li> </ul>

**SELECT Subscriptions.** Our SELECT subscription is a prepaid annual recurring subscription that accompanies a new or previously purchased perpetual license. We believe that the SELECT benefits summarized below support our favorable rates of account retention and growth:

- Software upgrades;
- Comprehensive technical support;
- License pooling providing accounts with efficiency advantages;
- Portfolio balancing providing accounts the opportunity to exchange unused or under used licenses with other of our license offerings;
- Learning benefits, Azure-based cloud collaboration services, and mobility advantages; and
- Access to our entire application portfolio with usage of licenses not previously purchased monetized quarterly in arrears based on consumption. See the section titled “— Term License Subscriptions” below.

**Enterprise Subscriptions.** Our Enterprise subscription offerings provide our largest accounts with complete and unlimited global access to our comprehensive portfolio of solutions.

- **Enterprise License Subscriptions (“ELS”).** Our ELS offering provides access to our comprehensive portfolio of solutions for a fixed annual fee. Subsequent annual renewals are based on the account’s usage of software in the preceding year, effectively an annual consumption-based arrangement. The majority of our ELS subscribers were historically SELECT subscribers that have grown into a position to take full advantage of our ELS offering.
- **Enterprise 365 (“E365 Subscriptions”).** Under our E365 subscription, participating accounts have unrestricted access to our comprehensive software portfolio, similar to ELS, however they are charged based upon daily usage, effectively a daily consumption-based arrangement. The daily usage fee also includes maintenance and Success Plan services, which are designed to achieve business outcomes through more efficient and effective use of our software. The E365 subscription offering was introduced in 2018. Prospectively, we plan to prioritize efforts to transition ELS subscribers to E365

subscriptions, primarily to simplify pricing, more closely align consumption to monetization, and to establish Success Plan services as recurring to ensure better business outcomes for our users. To the extent we succeed in transitioning subscribers to E365, under Topic 606 we would recognize a greater proportion of our revenues on a quarterly basis rather than substantially upfront. See the section titled “— Key Factors Impacting Comparability and Performance.”

#### *Term License Subscriptions*

*Annual Term Licenses (“ATL”) Subscription.* Annual term licenses are generally prepaid annually for named user access to specific products and include our newly introduced Practitioner Licenses. Annual term licenses are also used to monetize site or enterprise wide access for certain of our AssetWise solutions within given usage bands.

*Quarterly Term License (“QTL”) Subscription.* Through quarterly term licenses, accounts pay quarterly in arrears for licenses they have used representing usage beyond their contracted quantities. Much like our Enterprise subscription programs, a QTL allows smaller and medium-sized accounts to match usage to ongoing project requirements.

*Monthly Term License (“MTL”) Subscription.* Monthly term licenses are identical to QTL subscriptions, except for the term of the license, and the manner in which they are monetized. MTL subscriptions require a Cloud Services Subscription, which is discussed below.

*Visas and Passports.* Visas and Passports are quarterly or annual term licenses enabling users to access specific project or enterprise information and entitle certain functionality of our ProjectWise and AssetWise systems. Generally, a Passport provides desktop, web, and mobile application access to project information and certain functions, and a Visa provides similar access, plus added functionality depending upon the product to which the Visa is aligned.

While certain legacy arrangements are supported, our standard offering requires Visas and Passports to be fulfilled and contracted via a CSS, which is discussed below.

*Cloud Services Subscription (“CSS”).* CSS is designed to streamline the procurement, administration, and payment process for us and our accounts. A CSS requires an upfront annual estimation of MTL, Visa and Passport consumption, and any Success Plan services expected for the upcoming year. A deposit for the annual estimated consumption is submitted in advance. Actual consumption is monitored and invoiced against the deposit on a calendar quarter basis. Accounts are charged only for what gets used and deposited amounts never expire.

#### *Perpetual Licenses*

We historically have sold perpetual licenses and continue to offer them to our accounts as an available option for most of our applications. Perpetual licenses are available for accounts that prefer to own their software licenses and may be sold with or without attaching a SELECT subscription. Historically, attachment and retention of the SELECT subscription has been high given the benefits of the SELECT subscription.

#### *Professional Services*

We offer professional services, including training, implementation, configuration, customization, and strategic consulting services for all types of projects as requested by our accounts. We perform projects on both a time and materials and a fixed fee basis. We also offer our services using contractual structures based on (i) delivery of the services in the form of subscription-like, packaged offerings that are annually recurring in nature; and (ii) delivery of our growing portfolio of Success Plans in standard offerings that offer a level of subscription service over and above the standard technical support offered to all accounts as part of their SELECT or Enterprise agreement. Over time, we expect professional revenues using subscription and subscription-like contractual structures to make up a greater proportion of our professional services revenues.

#### *Examples of Typical Commercial Offering Combinations*

For the year ended December 31, 2019, under Topic 606, 25% of our revenues derive from ELS or E365 offerings, and 36% of our revenues derive from SELECT subscriptions. Our users often add further sources of revenue upon each of these foundational subscription offerings. Typical examples are as follows:

- An account contracts for its application solutions under its ELS or E365 as described above. In addition, if the account also utilizes our ProjectWise enterprise solution, it will estimate its prospective annual usage and make an incremental deposit into its CSS account. The CSS account will be drawn down quarterly based on actual usage and consumption of Passports and Visas. We deliver professional services for E365 accounts via the embedded Success Plan. An ELS account may contract for professional services under fixed fee or “days and rates” episodic arrangements billed separately, or it may contract for professional services in the form of Success Plans, which it pays for via its CSS.
- A SELECT subscription account pays a fixed annual subscription fee based on the number of perpetual licenses for applications which it owns. The account may purchase additional perpetual licenses to which an additional annual SELECT subscription fee will apply for each. Alternatively, the account may grow its application use via term licenses, which will be billed quarterly in arrears based on actual term license consumption. Alternatively, the account may estimate its annual term license requirements and make a deposit into its CSS account, with quarterly draw down based on actual usage and consumption. Contracting for term license usage via the CSS provides the account a slight economic advantage. Similar to the ELS or E365 subscriber, if the SELECT subscriber also utilizes our ProjectWise enterprise system, prospective annual usage will be estimated and a deposit made into a CSS account. The CSS account will be drawn down quarterly based on actual usage and consumption of Passports and Visas. For any professional services, the account may contract for professional services under fixed fee or “days and rates” episodic arrangements billed separately, or it may contract for professional services in the form of Success Plans, which it will pay for via its CSS.

#### Key Business Metrics:

We regularly review the following key metrics to evaluate our business, measure our performance, identify trends in our business, prepare financial projections, and make strategic decisions.

	Year Ended December 31,			Twelve Months Ended June 30,	
	2017	2018	2019	2019	2020
Last twelve-months recurring revenues (Topic 606)	\$521,923	\$586,466	\$631,097	\$606,411	\$665,659
Last twelve-months recurring revenues (Topic 605)	\$523,502	\$583,402	\$636,899	\$604,043	\$670,825
Constant Currency:					
ARR growth rate	9%	10%	12%	11%	11%
Account retention rate	98%	98%	98%	98%	98%
Recurring revenues dollar-based net retention rate	105%	107%	108%	106%	110%

**Last twelve-months recurring revenues.** Last twelve-months recurring revenues is calculated as recurring revenues recognized over the preceding twelve-month period. We define recurring revenues as subscriptions revenues that recur monthly, quarterly, or annually with specific or automatic renewal clauses and professional services revenues in which the underlying contract is based on a fixed fee and contains automatic annual renewal provisions.

Last twelve-months recurring revenues is presented using revenues recognized pursuant to Topic 606 as well as Topic 605 for all periods in order to enhance comparability during our transition to Topic 606. The Topic 606 unaudited amounts presented for the years ended December 31, 2017 and 2018 give effect to revenue adjustments as if the adoption of Topic 606 had occurred as of January 1, 2017 rather than January 1, 2019. For a reconciliation of the impact of adopting Topic 606 as if it had occurred as of January 1, 2017 on our audited consolidated statements of operations data for the years ended December 31, 2017 and 2018, see the section titled “Selected Consolidated Financial Data — Non-GAAP Financial Measures.”

On an annual and trailing twelve-month basis, we expect our recurring revenues recognized under Topic 606 to be comparable to such revenues recognized under Topic 605. This expectation is attributable to the



annual, recurring nature of our subscription agreements. However, the conversion of our existing subscription users to consumption-based offerings with consumption measurement durations of less than one year, such as our E365 program, as well as the term start date of new annual term license subscriptions, will introduce some volatility between annual and trailing twelve-month periods and impact period over period comparability. Specifically, in 2019, the conversion of existing ELS subscriptions to consumption-based E365 subscriptions resulted in a reduction of Topic 606 Enterprise subscriptions revenues of \$11,248 when compared to Topic 605. This impact was partly offset by higher annual term license subscriptions revenues under Topic 606 of \$5,714 due to the upfront recognition of license revenues of new subscriptions. See the section titled “Key Factors Impacting Comparability and Performance.”

We believe that last twelve-months recurring revenues is an important indicator of our performance during the immediately preceding twelve-month time period. We believe that we will continue to experience favorable growth in recurring revenues due to our strong account retention and recurring revenues dollar-based net retention rates as well as the addition of new accounts with recurring revenues. The last twelve-months recurring revenues under Topic 606 for the periods ended December 31, 2018, December 31, 2019, and June 30, 2020 compared to the last twelve-months of the preceding twelve-month period increased by \$64,543 (or \$59,900 under Topic 605), \$44,631 (or \$53,497 under Topic 605), and \$59,248 (or \$66,782 under Topic 605), respectively. These increases were primarily due to growth in ARR during the prior and current periods, which is primarily the result of consistent performance in our account retention rate and in our recurring revenues dollar-based net retention rate, as well as additional recurring revenues resulting from new accounts and acquisitions. For the twelve months ended December 31, 2019, 86% of our total revenues under Topic 606 (or 87% under Topic 605) were recurring revenues. For the twelve months ended June 30, 2020, 87% of our revenues were recurring revenues. Prospectively, we expect that this percentage is likely to remain consistent or modestly increase as we continue to target shifting episodic professional services revenues to subscriptions classified as recurring revenues.

**Constant currency metrics.** In reporting period-over-period results, we calculate the effects of foreign currency fluctuations and constant currency information by translating current period results using prior period average foreign currency exchange rates. Our definition of constant currency may differ from other companies reporting similarly named measures, and these constant currency performance measures should be viewed in addition to, and not as a substitute for, our operating performance measures calculated in accordance with U.S. GAAP.

**ARR growth rate.** Our ARR growth rate is the growth rate of our ARR, measured on a constant currency basis. Our ARR is defined as the sum of the annualized value of our portfolio of contracts that produce recurring revenue as of the last day of the reporting period, and the annualized value of the last three months of recognized revenues for our contractually recurring consumption-based software subscriptions with consumption measurement durations of less than one year. We believe that the last three months of recognized revenues, on an annualized basis, for our recurring software subscriptions with consumption measurement period durations of less than one year is a reasonable estimate of the annual revenues, given our consistently high retention rate and stability of usage under such subscriptions. ARR resulting from the annualization of recurring contracts with consumption measurement durations of less than one year, as a percentage of total ARR was 9%, 15%, and 25% as of December 31, 2017, 2018, and 2019, respectively, and 18% and 29% as of June 30, 2019 and 2020, respectively. Within our consumption-measured ARR, the successful uptake of our new E365 subscription offering has introduced daily consumption-measured ARR, representing 16% of total ARR as of June 30, 2020. ARR is inclusive of the ARR of acquired companies as of the date they are acquired. We believe that ARR and ARR growth are important metrics indicating the scale and growth of our business. Furthermore, we believe ARR, considered in connection with our account retention rate and our recurring revenues dollar-based net retention rate, is a leading indicator of revenue growth. Our ARR as of June 30, 2020 was \$697,682, calculated using the spot foreign exchange rates as of June 30, 2020.

There was no impact to our ARR growth rate from acquisitions for the year ended December 31, 2017. Our ARR growth rate was favorably impacted from acquisitions by 3% and 1% for the years ended December 31, 2018 and 2019, respectively, and by 1% and 2% for the twelve months ended June 30, 2019 and 2020, respectively.

*Account retention rate.* Our account retention rate for any given twelve-month period is calculated using the average currency exchange rates for the prior period, as follows: the prior period recurring revenues from all accounts with recurring revenues in the current and prior period, divided by total recurring revenues from all accounts during the prior period. The account retention rate is calculated using revenues recognized pursuant to Topic 605 for all periods in order to enhance comparability during our transition to Topic 606 as we do not have all information available to us necessary to present account retention rate pursuant to Topic 606 for any period prior to January 1, 2019. Our account retention rate is an important indicator that provides insight into the long-term value of our account relationships and our ability to retain our account base. We believe that our consistent and high account retention rates illustrate our ability to retain and cultivate long-term relationships with our accounts.

*Recurring revenues dollar-based net retention rate.* Our recurring revenues dollar-based net retention rate is calculated using the average exchange rates for the prior period, as follows: the recurring revenues for the current period, including any growth or reductions from existing accounts, but excluding recurring revenues from any new accounts added during the current period, divided by the total recurring revenues from all accounts during the prior period. A period is defined as any trailing twelve months. The recurring revenues dollar-based net retention rate is calculated using revenues recognized pursuant to Topic 605 for all periods in order to enhance comparability during our transition to Topic 606 as we do not have all information available to us necessary to present recurring revenues dollar-based net retention rate pursuant to Topic 606 for any period prior to January 1, 2019. We believe our recurring revenues dollar-based net retention rate is a key indicator of our success in growing our revenues within our existing accounts. Given that for the twelve months ended December 31, 2019 recurring revenues represented 86% of our total revenues under Topic 606, this metric helps explain our revenue performance as primarily growth into existing accounts. We believe that our consistent and high recurring revenues dollar-based net retention rate illustrates our ability to consistently retain accounts and grow them.

As discussed above, we expect annual and trailing twelve-month recurring revenues recognized under Topic 606 to be comparable to such revenues recognized under Topic 605 due to the annual, recurring nature of our subscription agreements. We, therefore, also expect, that our account retention rate and our recurring revenue dollar-based net retention rate under Topic 606 will be comparable to such metrics under Topic 605. However, under Topic 606, the conversion of our existing subscription users to consumption-based offerings with consumption measurement durations of less than one year, such as our E365 program, as well as the term start date of new subscriptions, will introduce some volatility between annual, and trailing twelve-month periods and impact period over period comparability. See the section titled “Key Factors Impacting Comparability and Performance.”

Our calculation of these metrics may not be comparable to other companies with similarly-titled metrics.

#### **Non-GAAP Financial Measures:**

In addition to our results determined in accordance with U.S. GAAP, we believe the below non-GAAP measures are useful in evaluating our operating performance. We use the below non-GAAP financial information, collectively, to evaluate our ongoing operations and for internal planning and forecasting purposes.

	Year Ended December 31,			Six Months Ended June 30,	
	2018	2019		2019	2020
	Topic 605	Topic 605	Topic 606	Topic 606	Topic 606
Adjusted EBITDA	\$171,768	\$186,598	\$188,129	\$79,384	\$115,506
Adjusted Net Income	\$132,246	\$135,471	\$135,049	\$59,978	\$ 89,203

For additional information, including the limitations of using non-GAAP financial measures, and reconciliations of the non-GAAP financial measures to the most directly comparable financial measures stated in accordance with U.S. GAAP, see the section titled “Selected Consolidated Financial Data — Non-GAAP Financial Measures.”

**Key Factors Impacting Comparability and Performance:**

*Impact of Topics 606 and 340-40.* On January 1, 2019, we adopted Topic 606, which supersedes substantially all existing revenue recognition guidance under U.S. GAAP. We adopted Topic 606 using the modified retrospective method, under which the cumulative effect of initially applying Topic 606 was recorded as a reduction to the opening balance of *Accumulated deficit* of \$125,464 (\$101,489, net of tax) as of January 1, 2019. We applied the standard only to contracts that were not completed as of the date of initial application. The comparative information has not been adjusted and continues to be reported under Topic 605.

The most significant impact from the adoption of Topic 606 relates to timing of revenue recognition for perpetual licenses and the accounting for certain of our subscription arrangements that include term-based software licenses bundled with support. Under Topic 605, revenue for perpetual licenses was recognized over a three-year period, while revenue attributable to the term-based software licenses was recognized ratably over the term. Under Topic 606, both perpetual license and prepaid term-based software license revenue will be recognized upfront upon delivery of the software license. Revenue recognition related to support, hosting, usage-based offerings, and services is substantially unchanged, with support and hosting revenue recorded ratably over the contract term, usage-based revenue recognized upon usage or delivery, and services revenue as delivered.

On an annual and trailing twelve-month basis, we expect our subscriptions revenues recognized under Topic 606 to be comparable to such revenues recognized under Topic 605. This expectation is attributable to the annual, recurring nature of our subscription agreements. However, quarterly subscription revenue and profitability trends will be impacted by the subscription term as well as the term start date of new and renewals subscriptions, due to the upfront revenue recognition of the associated term-license component. See the sections titled “— Quarterly Results of Operations” and “— Quarterly Trends” below.

Under Topic 605, our perpetual licenses revenues were recognized over a three-year period due to the portfolio balancing feature users obtain through their SELECT subscriptions. Under Topic 606, our perpetual licenses revenues are recognized upon delivery and will closely align with the respective license sales of the period.

Further, under Topic 606, the conversion of our existing subscription users to consumption-based offerings with consumption measurement durations of less than one year, such as our E365 program, will introduce some volatility between annual, quarterly, and trailing twelve-month periods and impact period over period comparability. This effect is because the term-based software license is recognized upfront upon delivery for prepaid subscription-based offerings, but upon usage for consumption-based offerings. For example, if an account renews an annual ELS at the beginning of July 2019, then we will recognize in 2019 the term-based software license of the annual subscription upon renewal for the twelve-month period from July 1, 2019 to June 30, 2020. However, if such account instead switches from our ELS offering to our consumption based E365 offering, then we will only recognize the distinct license component for the consumption period from July 1, 2019 to December 31, 2019 in 2019.

See Note 2 to our audited consolidated financial statements for the year ended December 31, 2019 included elsewhere in this prospectus for further information on the impact upon adoption of Topics 606 and 340-40 as of January 1, 2019.

*Impact of foreign currency.* A portion of our revenues and operating expenses were derived from outside the United States and as such, were denominated in various foreign currencies, including most significantly: Euros, British Pounds, Australian Dollars, Canadian Dollars, and Chinese Yuan Renminbi. Our financial results are therefore affected by changes in foreign currency rates. In 2019, 47% of our revenues were denominated in various foreign currencies. Correspondingly, in 2019, 46% of our operating expenses were denominated in various foreign currencies. Other than the natural hedge attributable to matching revenues and expenses in the same currencies, we do not currently hedge foreign currency exposure. Accordingly, our results of operations have been, and in the future will be, affected by changes in foreign exchange rates.

We identify the effects of foreign currency on our operations and present constant currency growth rates and fluctuations because we believe exchange rates are an important factor in understanding period to

period comparisons and enhance the understanding of our results and evaluation of our performance. In reporting period to period results, we calculate the effects of foreign currency fluctuations and constant currency information by translating current period results using prior period average foreign currency exchange rates. Our definition of constant currency may differ from other companies reporting similarly named measures, and these constant currency performance measures should be viewed in addition to, and not as a substitute for, our operating performance measures calculated in accordance with U.S. GAAP.

*Acquisitions.* Historically, we have enhanced our business with acquisitions of businesses, software solutions, and technologies. Going forward, we plan to selectively acquire adjacent software solutions that can be sold broadly across our account base, as well as to acquire new technologies that we can leverage across our existing software solution portfolio. We completed seven, four, two, and three acquisitions during the years ended December 31, 2018 and December 31, 2019 and the six months ended June 30, 2019 and 2020, respectively.

In accordance with Rule 3-05 of Regulation S-X, separate financial statements are not required for any of our acquisitions individually or in the aggregate.

*Income taxes.* The U.S. Tax Cuts and Jobs Act was enacted on December 22, 2017 and resulted in a provisional tax expense primarily due to the one-time transition tax on accumulated foreign subsidiary earnings and deferred tax impacts. We completed the accounting for the effects of the U.S. Tax Cuts and Jobs Act in the year ended December 31, 2018 and recorded a \$4,318 increase to tax expense related to provisional amounts recorded in 2017. In October 2018, we had intercompany sales of certain intangible operating assets between our foreign subsidiaries, which resulted in a non-recurring net tax benefit of \$46,369.

*Impact of COVID-19.* In March 2020, the World Health Organization declared a global pandemic related to the rapidly growing outbreak of the disease COVID-19, caused by a novel strain of coronavirus, SARS-CoV-2. The COVID-19 outbreak and certain preventative or protective actions that governments, businesses and individuals have taken in respect of COVID-19 have resulted in global business disruptions.

In response to the COVID-19 pandemic, we implemented a number of initiatives to ensure the safety of our colleagues and enable them to move to a work from home environment seamlessly and continue working effectively. These initiatives included providing our colleagues with necessary equipment, making certain that all colleagues had means of video and audio communications online, and guaranteeing that our network bandwidth was sufficient. Our business model is such that we had minimal disruption to our ability to deliver our solutions to accounts, and we did not have any loss of productivity during this transition. Almost all of our colleagues have been working from home since March 16, 2020, with a minority of our colleagues working in our office environments on a voluntary basis and abiding by appropriate distancing and sanitary regulations for their region. We communicated regularly and provided on-demand learning and support to our colleagues throughout the transition period. Based on a May 2020 internal survey, a majority of our colleagues are confident in the decisions that Bentley leadership is making regarding employee well-being and safety during this pandemic, and a majority of our colleagues believe that Bentley's response to and communication regarding COVID-19 has been timely and helpful.

The impact of the pandemic on our financial performance has been modest; our revenues have continued to grow given the mission critical nature of our solutions. For the months of March and April, our accounts' usage of our applications was down approximately 3-5% when compared to levels from the same periods in 2019; however, these metrics returned to pre-COVID-19 levels in June 2020. The modest and temporary dip in usage had limited impact on our recurring revenues, which are comprised primarily of longer term contracts. The growth of our revenues from perpetual licenses and professional services has been impacted as selected accounts have shifted spend to subscription solutions or delayed new projects. More recently, we have also experienced a modest decrease in revenues from certain accounts in the oil and gas industry that utilize our E365 subscription offering.

Moreover, we were quick to find ways to support our accounts and users, including the launch of a "Bentley Has Your Back" campaign to help our accounts take full advantage of their Bentley software. This campaign included producing over 50 self-help documents, 20 webinars, and several messages guiding users on various topics including how Bentley's solutions should be configured when working with limited bandwidth, how to use a SmartTV as a monitor, and how to leverage specific offerings such as ProjectWise to

facilitate collaboration in their own businesses in remote working environments. This guidance and assistance was well received by accounts and we believe helped maximize usage during the observed trough in March and April.

We have also taken measures to reduce selected operating expenses, including various costs associated with travel and facilities. Much of those resulting savings have been or will be re-invested in a portfolio of businesses outside of our core software business, with the objective of cultivating an ecosystem of digital integrator businesses.

Our business benefits from a resilient business model backed by industry tailwinds and a strong financial profile. We believe that significant public and private investment will continue to drive spend for infrastructure globally, which will continue to drive demand for our solutions. Additionally, we do not have any material account concentration; no single account or group of affiliated accounts represented more than 2.5% of our revenues for the year ended December 31, 2019. As of June 30, 2020, we had \$126 million of cash and cash equivalents, and \$293 million was available under the Credit Facility.

### **Components of Results of Operations:**

We manage our business globally within one operating segment, the development and marketing of computer software and related services, which is consistent with how our chief operating decision maker reviews and manages our business.

### **Revenues:**

We generate revenues from subscriptions, perpetual licenses, and professional services.

#### *Subscriptions*

*SELECT subscriptions:* We provide annual recurring subscriptions that accounts can elect to add to a new or previously purchased perpetual license. SELECT provides accounts with benefits, including upgrades, comprehensive technical support, pooled licensing benefits, annual portfolio balancing exchange rights, learning benefits, certain Azure-based cloud collaboration services, mobility advantages, and access to other available benefits. Under Topic 606, SELECT subscriptions revenues are recognized as distinct performance obligations are satisfied. Under Topic 605, SELECT subscriptions revenue was recognized on a ratable basis, over the subscription term.

*Enterprise subscriptions:* We provide Enterprise subscription offerings that provides our largest accounts with complete and unlimited global access to our comprehensive portfolio of solutions. ELS provides access for a prepaid annual fee. E365, which was introduced during the fourth quarter of 2018, provides unrestricted access to our comprehensive software portfolio, similar to ELS, however is charged based upon daily usage. The daily usage fee also includes maintenance and Success Plan services, which are designed to achieve business outcomes through more efficient and effective use of our software. The ELS and E365 programs both contain a distinct term license component. Under Topic 606, ELS revenue is recognized as the distinct performance obligations are satisfied. Under Topic 605, ELS revenue was recognized on a ratable basis, over the subscription term. E365 revenue is recognized based upon usage incurred by the account under both Topic 606 and 605.

*Term license subscriptions:* We provide annual, quarterly, and monthly term licenses for our software products. ATL subscriptions are generally prepaid annually for named user access to specific products. QTL subscriptions allow accounts to pay quarterly in arrears for licenses usage that is beyond their SELECT contracted quantities. MTL subscriptions are identical to QTL subscriptions, except for the term of the license, and the manner in which they are monetized. MTL subscriptions require a CSS, which is described below.

Visas and Passports are quarterly or annual term licenses enabling accounts to access specific project or enterprise information and entitle certain functionality of our ProjectWise and AssetWise systems. Our standard offerings are usage based with monetization through our CSS program. Under Topic 606, annual, quarterly, and monthly term licenses revenues are recognized as the distinct performance obligations for each are satisfied. Billings in advance are recorded as *Deferred revenues* in the consolidated balance sheets.

Under Topic 605, the subscriptions revenues were recognized on a ratable basis, over the subscription term. QTL, MTL, Visas and Passports subscriptions are recognized based upon usage incurred by the account under both Topic 606 and 605.

CSS is a program designed to streamline the procurement, administration, and payment process. The program requires an estimation of annual usage for CSS eligible offerings and a deposit of funds in advance. Actual consumption is monitored and invoiced against the deposit on a calendar quarter basis. CSS balances not utilized for eligible products or services may roll over to future periods or are refundable. Paid and unconsumed CSS balances are recorded in *Accruals and other current liabilities* in the consolidated balance sheets. Software and services consumed under CSS are recognized pursuant to the applicable revenue recognition guidance for the respective software or service and classified as subscriptions or services based on their respective nature.

#### *Perpetual licenses*

Perpetual licenses may be sold with or without attaching a SELECT subscription. Historically, attachment and retention of the SELECT subscription has been high given the benefits of the SELECT subscription discussed above. Perpetual licenses revenues are recognized upon delivery of the license to the user under Topic 606. Under Topic 605, we recognized perpetual licenses revenues ratably over a three-year term due to the portfolio balancing feature users obtain through their SELECT subscriptions.

#### *Services*

We provide professional services including training, implementation, configuration, customization, and strategic consulting services. We perform projects on both a time and materials and a fixed fee basis. Our recent and preferred contractual structures for delivering professional services include (i) delivery of services in the form of subscription-like, packaged offerings that are annually recurring in nature, and (ii) delivery of our growing portfolio of Success Plans. Success Plans are standard offerings that offer a level of subscription service above the standard technical support offered to all accounts as part of their SELECT or Enterprise agreement. Revenues are recognized as services are performed under both Topic 606 and 605.

#### ***Headcount-related costs***

For the year ended December 31, 2019, 80% of our aggregate cost of revenues, research and development, selling and marketing, and general and administrative costs were represented by what we refer to herein as “headcount-related” costs. These costs include the salary costs of our colleagues (our employees) and the corresponding incentives, benefits, employment taxes, and travel-related costs. Our headcount-related costs are variable in nature. We actively manage these costs to align to our trending run rate of revenue performance, with the objective of enhancing visibility and predictability of resulting operating profit margins.

#### ***Cost of subscriptions, licenses, and services***

*Cost of subscriptions and licenses.* Cost of subscriptions and licenses includes salaries and other related costs, including the depreciation of property and equipment and the amortization of capitalized software costs associated with servicing software subscriptions, the amortization of intangible assets associated with acquired software and technology, channel partner compensation for providing sales coverage to subscribers, as well as cloud-related costs incurred for servicing our accounts using cloud deployed hosted solutions and our license administration platform.

*Cost of services.* Cost of services includes salaries for internal and third-party personnel and related overhead costs, including depreciation of property and equipment, for providing training, implementation, configuration, and customization services to accounts, amortization of capitalized software costs, and related out-of-pocket expenses incurred.

#### ***Operating expenses***

*Research and development.* Research and development expenses, which are generally expensed as incurred, primarily consist of personnel and related costs of our research and development staff, including

salaries, benefits, bonuses, stock-based compensation, and costs of certain third-party contractors, as well as allocated overhead costs. We expense software development costs, including costs to develop software products or the software component of products to be sold, leased, or marketed to external accounts, before technological feasibility is reached. Technological feasibility is typically reached shortly before the release of such products and as a result, development costs that meet the criteria for capitalization were not material for the periods presented.

We capitalize certain development costs related to certain projects under our ACDP (our structured approach to an in-house business incubator function) once technological feasibility is established. Technological feasibility is established when a detailed program design has been completed and documented; we have established that the necessary skills, hardware, and software technology are available to produce the product; and there are no unresolved high-risk development issues. Once the software is ready for its intended use, amortization is recorded over the software's estimated useful life (generally three years). During the years ended December 31, 2018 and December 31, 2019 and the six months ended June 30, 2019 and June 30, 2020, total costs capitalized under the ACDP were \$5,735, \$6,060, \$2,181 and \$4,260, respectively. Additionally, during the years ended December 31, 2018 and December 31, 2019 and the six months ended June 30, 2019 and June 30, 2020, total ACDP related amortization recorded in *Costs of subscriptions and licenses* was \$2,052, \$3,516, \$1,448 and \$2,022, respectively.

*Selling and marketing.* Selling and marketing expenses include salaries, benefits, bonuses, and stock-based compensation expense for our selling and marketing colleagues, the expense of travel, entertainment and training for such personnel, online marketing, product marketing and other brand-building activities, such as advertising, trade shows, and expositions, various sales and promotional programs, and costs of computer equipment and facilities used in selling and marketing activities. We anticipate that we will continue to make strategic investments in our global business systems and methods to enhance major account sales activities and to support our worldwide sales and marketing strategies, and the business in general. Topic 340-40 requires the capitalization of certain incremental costs of obtaining a contract, which impacts the period in which we record sales commission expense. Historically, under Topic 605, we recognized commissions expense as incurred. Under Topic 340-40, we are required to recognize these expenses over the period of benefit associated with these costs, resulting in a deferral of certain contract costs each period. The contract costs are amortized based on the economic life of the goods and services to which the contract costs relate. We have determined that certain sales incentive programs meet the requirements to be capitalized. We apply a practical expedient to expense costs as incurred for costs to obtain a contract with a customer when the amortization period would have been one year or less. These costs include our internal sales force compensation program and certain channel partner sales incentive programs for which the annual compensation is commensurate with annual sales activities.

*General and administrative.* General and administrative expenses include salaries, bonuses, benefits, and stock-based compensation expense for our finance, human resources, and legal colleagues, the expense of travel, entertainment, and training for such personnel, professional fees for legal and accounting services, and costs of computer equipment and facilities used in general and administrative activities.

We expect to recognize certain non-recurring costs as part of our transition to a publicly-traded company, consisting of professional fees and other expenses. These fees are being expensed in the period incurred. We expect to incur \$2.0 million in audit fees, \$3.3 million in legal fees and expenses and \$16.6 million in underwriting discounts and commissions applicable to the sale of shares by the selling stockholders in connection with this offering. Following the completion of this offering, we expect to continue to incur additional expenses as a result of operating as a public company, including costs to comply with the rules and regulations applicable to companies listed on a U.S. securities exchange and costs related to compliance and reporting obligations pursuant to the rules and regulations of the SEC. In addition, as a public company, we expect to incur increased expenses in the areas of insurance, investor relations, and professional services. As a result, we expect the dollar amount of our general and administrative expenses to increase for the foreseeable future. We expect, however, that our general and administrative expenses will decrease as a percentage of our revenues over time, although the percentage may fluctuate from period to period depending on fluctuations in our revenue and the timing and extent of our general and administrative expenses.

*Amortization of purchased intangibles.* Amortization of purchased intangibles includes the amortization of acquired non-product related intangible assets, primarily customer relationships, trademarks, and non-compete agreements recorded in connection with completed acquisitions.

*Interest expense, net.* Interest expense, net primarily represents interest associated with the Credit Facility, amortization of deferred financing costs, and interest income from our investments in money market funds.

*Other income (expense), net.* Other income (expense), net primarily consists of foreign currency translation results derived primarily from U.S. Dollar denominated intercompany balances, cash and cash equivalents, and accounts receivable held by foreign subsidiaries with non-U.S. Dollar functional currencies.

*Provision for income taxes.* Provision for income taxes includes the aggregate consolidated income tax expense for U.S. domestic and foreign income taxes.

*Equity in loss of joint venture, net of tax.* Equity in loss of joint venture includes our proportional share of loss in a joint venture accounted for under the equity method.



**Results of operations:**

The following table sets forth selected consolidated statements of operations data for each of the periods indicated:

	Year Ended December 31,		Six Months Ended June 30,	
	2018	2019	2019	2020
<b>Revenues:</b>				
Subscriptions	\$ 557,421	\$ 608,300	\$ 290,147	\$ 327,837
Perpetual licenses	61,065	59,693	24,468	23,193
Subscriptions and licenses	618,486	667,993	314,615	351,030
Services	73,224	68,661	32,529	27,950
Total revenues	691,710	736,654	347,144	378,980
<b>Cost of revenues:</b>				
Cost of subscriptions and licenses	55,113	71,578	30,831	43,128
Cost of services	76,211	72,572	38,367	30,836
Total cost of revenues	131,324	144,150	69,198	73,964
Gross profit	560,386	592,504	277,946	305,016
<b>Operating expenses:</b>				
Research and development	175,032	183,552	91,861	89,353
Selling and marketing	160,635	155,294	75,168	65,727
General and administrative	89,328	97,580	46,307	52,269
Amortization of purchased intangibles	14,000	14,213	6,852	7,115
Total operating expenses	438,995	450,639	220,188	214,464
Income from operations	121,391	141,865	57,758	90,552
Interest expense, net	(8,765)	(8,199)	(4,474)	(2,516)
Other income (expense), net	236	(5,557)	(1,747)	(6,985)
Income before income taxes	112,862	128,109	51,537	81,051
Provision for income taxes	(29,250)	23,738	5,119	11,440
Equity in loss of joint venture, net of tax	—	1,275	—	866
Net income	142,112	103,096	46,418	68,745
Less: Net income attributable to participating securities	(4)	(8)	(12)	—
Net income per share attributable to Class A and Class B common shares	\$ 142,108	\$ 103,088	\$ 46,406	\$ 68,745
<b>Net income per share:</b>				
Basic	\$ 0.50	\$ 0.36	\$ 0.16	\$ 0.24
Diluted	\$ 0.49	\$ 0.35	\$ 0.16	\$ 0.23
Weighted average shares outstanding, basic	285,805,096	284,625,642	285,529,476	286,068,766
Weighted average shares outstanding, diluted	292,624,496	293,796,707	293,633,255	295,595,234

**Comparison of the Six Months Ended June 30, 2019 and June 30, 2020**

In reporting period-over-period results, we calculate the effects of foreign currency fluctuations and constant currency information by translating current period results using prior period average foreign currency exchange rates. Our definition of constant currency may differ from other companies reporting similarly named measures, and these constant currency performance measures should be viewed in addition to, and not as a substitute for, our operating performance measures calculated in accordance with U.S. GAAP.

*Revenues*

	Six Months Ended June 30,		Comparison		
			Amount	%	Constant
	2019	2020			
Revenues:					
Subscriptions	\$290,147	\$327,837	\$37,690	13.0%	14.3%
Perpetual licenses	24,468	23,193	(1,275)	(5.2)%	(2.9)%
Subscriptions and licenses	314,615	351,030	36,415	11.6%	13.0%
Services	32,529	27,950	(4,579)	(14.1)%	(13.0)%
Total revenues	<u>\$347,144</u>	<u>\$378,980</u>	<u>\$31,836</u>	9.2%	10.5%

Total revenues increased by \$31,836, or 9.2%, to \$378,980 for the six months ended June 30, 2020. This increase was driven primarily by improvements in our organic performance of \$25,182, and to a lesser extent, the impact from acquisitions of \$11,384, partially offset by negative foreign currency effects due to a stronger U.S. Dollar relative to our other functional currencies of \$4,730. On a constant currency basis, our revenues increased by 10.5% for the six months ended June 30, 2020 as compared to the prior period.

- *Subscriptions.* Subscriptions revenues increased by \$37,690, or 13.0%, for the six months ended June 30, 2020 as compared to the six months ended June 30, 2019. This increase was driven primarily by improvements in our organic performance of \$35,510, and to a lesser extent, the impact from acquisitions of \$5,980, partially offset by negative foreign currency effects due to a stronger U.S. Dollar relative to our other functional currencies of \$3,800. On a constant currency basis, our subscriptions revenues increased by 14.3% for the six months ended June 30, 2020 as compared to the prior period.

The increase in organic performance was primarily due to expansion within our existing accounts, as reflected by our recurring revenues dollar-based net retention rate of 110%. Approximately 3% of the increase was attributed to new accounts. Approximately 50% of our organic performance expansion was driven by ProjectWise and civil design products.

- *Perpetual licenses.* Perpetual licenses revenues decreased by \$1,275, or 5.2%, for the six months ended June 30, 2020 as compared to the six months ended June 30, 2019. This decrease was driven by a reduction in our organic performance of \$1,893, as well as by negative foreign currency effects due to a stronger U.S. Dollar relative to our other functional currencies of \$570, partially offset by the impact from acquisitions of \$1,188. On a constant currency basis, our perpetual licenses revenues decreased by 2.9% for the six months ended June 30, 2020 as compared to the prior period.

We observed a decrease in organic performance during the three months ended June 30, 2020 as certain accounts delayed purchase decisions or shifted spend to subscription solutions due to COVID-19.

- *Services.* Services revenues decreased by \$4,579, or 14.1%, for the six months ended June 30, 2020 as compared to the six months ended June 30, 2019. This decrease was driven primarily by a reduction in our organic performance of \$8,435, as well as by negative foreign currency effects due to a stronger U.S. Dollar relative to our other functional currencies of \$360, partially offset by the impact from acquisitions of \$4,216. On a constant currency basis, our services revenues decreased by 13.0% for the six months ended June 30, 2020 as compared to the prior period.

The decrease in organic performance was primarily due to the winding down or completion of several larger services projects during 2019 and early 2020, COVID-19 related delays of new projects while social distancing measures are in place, the inclusion of learning benefits in our subscription offerings, and the partial redeployment of our services colleagues to support Success Plan services of our E365 subscription offering.

#### Revenues by Geographic Area

Revenues are allocated to individual countries based upon the location of the users. Revenues by geographic area are as follows:

	Six Months Ended June 30,		Comparison		
			Amount	%	Constant
	2019	2020			
<b>Revenues by Geographic Area</b>					
Americas	\$167,440	\$185,838	\$18,398	11.0%	11.4%
EMEA	115,811	121,578	5,767	5.0%	7.3%
APAC	63,893	71,564	7,671	12.0%	14.1%
Total revenues by geographic area	<u>\$347,144</u>	<u>\$378,980</u>	<u>\$31,836</u>	9.2%	10.5%

- *Americas.* Revenues from the Americas increased by \$18,398, or 11.0%, for the six months ended June 30, 2020 as compared to the six months ended June 30, 2019. This increase was driven primarily by improvements in our organic performance of \$12,274 and, to a lesser extent, the impact from acquisitions of \$6,789, partially offset by negative foreign currency effects due to a stronger U.S. Dollar relative to our other functional currencies of \$665. On a constant currency basis, our revenues from the Americas increased by 11.4% for the six months ended June 30, 2020 as compared to the prior period.

The increase in organic performance was primarily due to expansion of our recurring revenues from our existing accounts in the United States and Canada. Approximately 50% of our organic performance expansion was driven by ProjectWise.

- *EMEA.* Revenues from EMEA increased by \$5,767, or 5.0%, for the six months ended June 30, 2020 as compared to the six months ended June 30, 2019. This increase was driven primarily by improvements in our organic performance of \$4,350 and, to a lesser extent, the impact from acquisitions of \$4,113, partly offset by negative foreign currency effects due to a stronger U.S. Dollar relative to our other functional currencies of \$2,696. On a constant currency basis, our revenues from EMEA increased by 7.3% for the six months ended June 30, 2020 as compared to the prior period.

The increase in organic performance was primarily due to expansion of our recurring revenues throughout the region. Approximately 60% of our organic performance expansion was driven by ProjectWise.

- *APAC.* Revenues from APAC increased by \$7,671, or 12.0%, for the six months ended June 30, 2020 as compared to the six months ended June 30, 2019. This increase was driven primarily by improvements in our organic performance of \$8,558 and, to a lesser extent, the impact from acquisitions of \$482, partially offset by negative foreign currency effects due to a stronger U.S. Dollar relative to our other functional currencies of \$1,369. On a constant currency basis, our revenues from APAC increased by 14.1% for the six months ended June 30, 2020 as compared to the prior period.

The increase in organic performance was primarily due to expansion of our recurring revenues from our existing accounts in Australia and China. Approximately 50% of our organic performance expansion was driven by ProjectWise and Offshore Structural Analysis products.

*Cost of Revenues*

	Six Months Ended June 30,		Comparison		
			Amount	%	Constant
	2019	2020			
Cost of subscriptions and licenses	\$30,831	\$43,128	\$12,297	39.9%	41.9%
Cost of services	38,367	30,836	(7,531)	(19.6)%	(17.9)%
Total cost of revenues	<u>\$69,198</u>	<u>\$73,964</u>	<u>\$ 4,766</u>	6.9%	8.7%

Cost of revenues increased by \$4,766, or 6.9%, to \$73,964 for the six months ended June 30, 2020. This increase was driven primarily by an increase in cost of subscriptions and licenses, partially offset by lower cost of services relative to the prior period. On a constant currency basis, total cost of revenues increased by 8.7% for the six months ended June 30, 2020 as compared to the prior period.

Cost of subscriptions and licenses increased 39.9%, or 41.9% in constant currency, as compared to the six months ended June 30, 2019. On a constant currency basis, this increase was primarily due to an increase in hosting costs of approximately \$5,600, an increase in salaries, incentive compensation, and other headcount-related costs of approximately \$5,000, and an increase in amortization expense of approximately \$1,100 for software and technology.

Cost of services decreased by 19.6%, or 17.9% in constant currency, as compared to the six months ended June 30, 2019. On a constant currency basis, the decrease was primarily due to a decrease in salaries, incentive compensation, and other headcount-related costs of approximately \$2,600 as well as a decrease in the recognition of previously capitalized costs related to certain professional services projects of approximately \$3,700.

*Operating Expenses*

	Six Months Ended June 30,		Comparison		
			Amount	%	Constant
	2019	2020			
Research and development	\$ 91,861	\$ 89,353	\$(2,508)	(2.7)%	(1.3)%
Selling and marketing	75,168	65,727	(9,441)	(12.6)%	(10.6)%
General and administrative	46,307	52,269	5,962	12.9%	13.7%
Amortization of purchased intangibles	6,852	7,115	263	3.8%	5.3%
Total operating expenses	<u>\$220,188</u>	<u>\$214,464</u>	<u>\$(5,724)</u>	(2.6)%	(1.1)%

*Research and development.* Research and development expenses decreased 2.7%, or 1.3% in constant currency, as compared to the six months ended June 30, 2019. On a constant currency basis, the decrease was primarily due to COVID-19 related modification to employee travel and variable compensation plans resulting in a net decrease in salaries, incentive compensation, and other headcount-related costs of approximately \$700, as well as a decrease in facility-related costs of approximately \$600.

*Selling and marketing.* Selling and marketing expenses decreased 12.6%, or 10.6% in constant currency, as compared to the six months ended June 30, 2019. The decrease is primarily caused by COVID-19 related modification to employee travel and variable compensation plans resulting in a net decrease in salaries, incentive compensation, and other headcount-related costs of approximately \$6,000, as well as a reduction in promotional costs of \$1,100, substantially from rationalizing our marketing spend and shifting to virtual events given the evolving business environment as a result of COVID-19.

*General and administrative.* General and administrative expenses increased 12.9%, or 13.7% in constant currency, as compared to the six months ended June 30, 2019. On a constant currency basis, the increase was primarily caused by an increase in salaries, incentive compensation, and other headcount-related costs of approximately \$4,300, as well as approximately \$1,600 related to acquisition and integration costs and other corporate initiatives.

*Amortization of purchased intangibles.* Amortization of purchased intangibles increased by 3.8%, or 5.3% in constant currency, as compared to the six months ended June 30, 2019. The increase was primarily attributable to acquisitions that closed in the last six months of 2019 and the first six months of 2020.

*Interest Expense, Net*

	<u>Six Months Ended June 30,</u>	
	<u>2019</u>	<u>2020</u>
Interest expense	\$(5,021)	\$(2,846)
Interest income	547	330
Total interest expense, net	<u>\$(4,474)</u>	<u>\$(2,516)</u>

	<u>Six Months Ended June 30,</u>	
	<u>2019</u>	<u>2020</u>
Bank credit facility	\$(4,600)	\$(2,544)
Amortization of deferred financing costs	(277)	(277)
Other, net	403	305
Total interest expense, net	<u>\$(4,474)</u>	<u>\$(2,516)</u>

Our net interest expense for the six months ended June 30, 2020 decreased from the prior year period primarily due to a lower outstanding balance on the Credit Facility combined with a lower average interest rate.

*Other Income (Expense), Net*

	<u>Six Months Ended June 30,</u>	
	<u>2019</u>	<u>2020</u>
Foreign exchange loss	\$(1,588)	\$(4,263)
Other income, net	(159)	(2,722)
Total other income (expense), net	<u>\$(1,747)</u>	<u>\$(6,985)</u>

Other income (expense), net for the six months ended June 30, 2019 and 2020 primarily consists of foreign currency translation losses of \$1,588 and \$4,263, respectively. The foreign currency translation losses derive primarily from U.S. Dollar denominated intercompany balances, cash and cash equivalents, and accounts receivable held by foreign subsidiaries with non-U.S. Dollar functional currencies. These U.S. Dollar denominated balances are being translated into their functional currencies at the rates in effect at the balance sheet date and fully eliminate in consolidation. The gains and losses from such translations are included in *Other income (expense), net*. For the six months ended June 30, 2019 and 2020, intercompany loan balances resulted in unrealized foreign currency translation losses of \$1,680 and \$1,765, respectively.

Other income (expense), net also includes a loss from the change in fair value of the Company's interest rate swap of \$4,174, partly offset by a gain from the change in fair value of an acquisition contingent consideration of \$1,390 for the six months ended June 30, 2020.

*Provision for Income Taxes*

The income tax provisions for the six months ended June 30, 2019 and 2020 were based on the estimated annual effective income tax rates adjusted for discrete items occurring during the periods presented. During the six months ended June 30, 2019 and 2020, we recognized an aggregate consolidated income tax expense of \$5,119 and \$11,440, respectively, for U.S. domestic and foreign income taxes. During the six months ended June 30, 2019 and 2020, we recorded a discrete tax benefit of \$3,653 and \$6,423, respectively, associated with stock-based compensation. The effective income tax rate of 9.9% for the six months ended June 30, 2019 was lower than the effective income tax rate of 14.1% for the same period in the current year primarily as a result of a change in the timing and mix of U.S. and foreign income.

*Equity in Loss of Joint Venture, Net of Tax*

In September 2019, we and Topcon Positioning Systems, Inc. formed DCW. DCW's focus is to transform the construction industry from its legacy document-centric paradigm by simplifying and enabling digital automated workflows and processes, technology integration, and digital twinning services for infrastructure.

We have a 50% ownership in DCW and apply the equity method of accounting for our investment in DCW. Under the equity method, we recorded our initial investment in the joint venture at cost and subsequently adjust that investment by our proportional share of income or losses in DCW. For the six months ended June 30, 2020, the equity in loss, net of tax, related to the investment was \$866.

*Net Income*

	<b>Six Months Ended June 30,</b>	
	<b>2019</b>	<b>2020</b>
Net income	\$46,418	\$68,745

For the six months ended June 30, 2020, net income increased by \$22,327, or 48%, compared to the six months ended June 30, 2019. The change is due to the factors stated above.

*Adjusted EBITDA and Adjusted Net Income*

	<b>Six Months Ended June 30,</b>	
	<b>2019</b>	<b>2020</b>
Adjusted EBITDA	\$79,384	\$115,506
Adjusted Net Income	\$59,978	\$ 89,203

For the six months ended June 30, 2020, Adjusted EBITDA increased by \$36,122 compared to the six months ended June 30, 2019. These increases were primarily due to an increase in income from operations, net of adjustments discussed in the section titled "Selected Consolidated Financial Data."

Adjusted EBITDA as a percentage of revenue was 23% and 30% for the six months ended June 30, 2019 and 2020, respectively.

For the six months ended June 30, 2020, Adjusted Net Income increased by \$29,225 compared to the six months ended June 30, 2019. These increases were primarily due to an increase in income from operations net of adjustments discussed in the section titled "Selected Consolidated Financial Data."

Adjusted Net Income as a percentage of revenue was 17% and 24% for the six months ended June 30, 2019 and 2020, respectively.

For additional information, including the limitations of using non-GAAP financial measures, and reconciliations of the non-GAAP financial measures to the most directly comparable financial measures stated in accordance with U.S. GAAP, see the section titled "Selected Consolidated Financial Data — Non-GAAP Financial Measures."

*Comparison of the Years Ended December 31, 2018 and 2019*

In reporting period-over-period results, we calculate the effects of foreign currency fluctuations and constant currency information by translating current period results using prior period average foreign currency exchange rates. Our definition of constant currency may differ from other companies reporting similarly named measures, and these constant currency performance measures should be viewed in addition to, and not as a substitute for, our operating performance measures calculated in accordance with U.S. GAAP.

## Revenues

	Year Ended December 31,		Comparison					
	2018	2019	Amount	%	Impact from Adoption of Topic 606	Remaining Difference	%	Constant Currency %
	As reported Topic 605	As reported Topic 606						
<b>Revenues:</b>								
Subscriptions	\$ 557,421	\$ 608,300	\$50,879	9.1%	\$(5,625)	\$ 56,504	10.1%	12.9%
Perpetual licenses	61,065	59,693	(1,372)	(2.2)%	7,174	(8,546)	(14.0)%	(11.1)%
Subscriptions and licenses	618,486	667,993	49,507	8.0%	1,549	47,958	7.8%	10.5%
Services	73,224	68,661	(4,563)	(6.2)%	256	(4,819)	(6.6)%	(4.8)%
Total revenues	<u>\$ 691,710</u>	<u>\$ 736,654</u>	<u>\$44,944</u>	6.5%	<u>\$ 1,805</u>	<u>\$ 43,139</u>	6.2%	8.9%

For the year ended December 31, 2019, revenues as reported under Topic 606 increased by \$44,944, or 6.5%, to \$736,654 as compared to \$691,710 under Topic 605 for the year ended December 31, 2018, with subscriptions revenues increasing by 9.1%, perpetual licenses revenues decreasing by 2.2%, and services revenues decreasing by 6.2%.

The change in revenues was significantly impacted by the adoption of Topic 606, which impacted the timing, allocation, and presentation of subscriptions, perpetual licenses, and services revenues. The most significant impact from the adoption of Topic 606 relates to timing of revenue recognition for perpetual licenses and the accounting for certain of our subscription arrangements that include term-based software licenses bundled with support. Under Topic 606, both perpetual license and prepaid term-based software license revenues are recognized upfront upon delivery of the software license. Under Topic 605, revenue for perpetual licenses was recognized over a three-year period, while revenue attributable to the term-based software licenses was recognized ratably over the term. Revenue recognition related to support, hosting, usage-based offerings, and services is substantially unchanged, with support and hosting revenue recorded ratably over the contract term, usage-based revenue recognized upon usage or delivery, and services revenue recognized as delivered. The adoption of Topic 606 resulted in a net reduction in subscriptions revenues of \$5,625, and a net increase in perpetual licenses revenues of \$7,174 for the year ended December 31, 2019. The Company's services revenues have not been significantly impacted by the adoption of Topic 606. On an annual basis, we expect our subscriptions revenues recognized under Topic 606 to be comparable to such revenues recognized under Topic 605. This expectation is attributable to the annual, recurring nature of our subscription agreements. However, under Topic 606, the conversion of our existing subscription users to consumption-based offerings with consumption measurement durations of less than one year, such as our E365 program, as well as the term start date of new annual term license subscriptions, introduces some volatility between periods and impacts period-over-period comparability. For additional information, see the section titled "Key Factors Impacting Comparability and Performance." For additional information on the impact of adoption of Topic 606 on our results, see Note 2 to the audited consolidated financial statements included elsewhere in the prospectus.

Net of the impact from adopting Topic 606 of \$1,805, total revenues increased by \$43,139, or 6.2%, for the year ended December 31, 2019. This increase was driven primarily by improvements in our organic performance of \$53,827, and to a lesser extent, the impact from acquisitions of \$7,597, partially offset by negative foreign currency effects due to a stronger U.S. Dollar relative to our other functional currencies of \$18,285. On a constant currency basis and net of the impact from adopting Topic 606, our revenues increased by 8.9% for the year ended December 31, 2019 as compared to the prior period.

- *Subscriptions.* Net of the decrease from adopting Topic 606 of \$5,625, subscriptions revenues increased by \$56,504, or 10.1%, for the year ended December 31, 2019 as compared to the year ended December 31, 2018. This increase was driven primarily by improvements in our organic performance of \$61,325, and to a lesser extent, the impact from acquisitions of \$10,448, partially offset by negative foreign currency effects due to a stronger U.S. Dollar relative to our other functional

currencies of \$15,269. On a constant currency basis and net of the impact from adopting Topic 606, our subscriptions revenues increased by 12.9% for the year ended December 31, 2019 as compared to the prior period.

The increase in organic performance was primarily due to expansion within our existing accounts, as reflected by our recurring revenues dollar-based net retention rate of 108%. Approximately 2% of the increase was attributed to new accounts. Approximately 50% of our organic performance expansion was driven by ProjectWise and civil design products.

- *Perpetual licenses.* Net of the increase from adopting Topic 606 of \$7,174, perpetual licenses revenues decreased by \$8,546, or 14.0%, for the year ended December 31, 2019 as compared to the year ended December 31, 2018. This decrease was driven by a reduction in our organic performance of \$2,735, the net negative impact from acquisitions and acquisition integration of \$4,069, as well as by negative foreign currency effects due to a stronger U.S. Dollar relative to our other functional currencies of \$1,742. On a constant currency basis and net of the impact from adopting Topic 606, our perpetual licenses revenues decreased by 11.1% for the year ended December 31, 2019 as compared to the prior period.

The negative impact from acquisition integration of \$4,498 relates to a 2018 acquisition. In 2018 we recognized perpetual license revenues from this acquisition of \$4,061. License revenues were recognized upon delivery. Upon completing acquisition integration and beginning in 2019, such license sales were subject to our SELECT subscription program, including the portfolio balancing performance obligation. As a result, beginning in 2019 we would have recognized such license revenues ratably over a three-year period under Topic 605. In connection with this acquisition, we sold \$6,317 of licenses in 2019, of which \$823 was ratably recognized in 2019 and the balance of \$5,494 was deferred under Topic 605. For comparison purposes, under Topic 606, revenue of \$6,317 was recognized upon delivery in 2019.

- *Services.* Net of the increase from adopting Topic 606 of \$256, services revenues decreased by \$4,819, or 6.6%, for the year ended December 31, 2019 as compared to the year ended December 31, 2018. This decrease was driven primarily by a reduction in our organic performance of \$4,763, as well as by negative foreign currency effects due to a stronger U.S. Dollar relative to our other functional currencies of \$1,274, partially offset by the impact from acquisitions of \$1,218. On a constant currency basis and net of the impact from adopting Topic 606, our services revenues decreased by 4.8% for the year ended December 31, 2019 as compared to the prior period.

The decrease in organic performance was primarily due to the completion of several larger services projects during 2018 and the partial redeployment of our services colleagues to support Success Plan services of our E365 subscription offering.

#### Revenues by Geographic Area

Revenues are allocated to individual countries based upon the location of the users. Revenues by geographic area are as follows:

	Year Ended December 31,		Comparison					
	2018	2019	Amount	%	Impact from Adoption of Topic 606	Remaining Difference	%	Constant Currency %
	As reported Topic 605	As reported Topic 606						
<b>Revenues by Geographic Area</b>								
Americas	\$ 328,749	\$ 356,331	\$27,582	8.4%	\$(4,603)	\$ 32,185	9.8%	10.8%
EMEA	231,486	236,602	5,116	2.2%	1,348	3,768	1.6%	6.0%
APAC	131,475	143,721	12,246	9.3%	5,060	7,186	5.5%	9.1%
Total revenues by geographic area	\$ 691,710	\$ 736,654	\$44,944	6.5%	\$ 1,805	\$ 43,139	6.2%	8.9%



For the year ended December 31, 2019, revenues reported under Topic 606 for our Americas, EMEA and APAC geographic areas, as compared to the revenues reported under Topic 605 for the year ended December 31, 2018, increased by \$27,582, or 8.4%, \$5,116, or 2.2%, and \$12,246, or 9.3%, respectively.

- *Americas.* Net of the decrease from adopting Topic 606 of \$4,603, revenues from the Americas increased by \$32,185, or 9.8%, for the year ended December 31, 2019 as compared to the year ended December 31, 2018. This increase was driven primarily by improvements in our organic performance of \$30,993 and, to a lesser extent, the impact from acquisitions of \$4,527, partially offset by negative foreign currency effects due to a stronger U.S. Dollar relative to our other functional currencies of \$3,335. On a constant currency basis and net of the impact from adopting Topic 606, our revenues from the Americas increased by 10.8% for the year ended December 31, 2019 as compared to the prior period.

The increase in organic performance was primarily due to expansion of our recurring revenues from our existing accounts in the United States and Canada. Approximately 50% of our organic performance expansion was driven by ProjectWise and civil design products.

- *EMEA.* Net of the increase from adopting Topic 606 of \$1,348, revenues from EMEA increased by \$3,768, or 1.6%, for the year ended December 31, 2019 as compared to the year ended December 31, 2018. This increase was driven primarily by improvements in our organic performance of \$11,665 and, to a lesser extent, the impact from acquisitions of \$6,818, partly offset by the negative impact from acquisition integration of \$4,498 and by negative foreign currency effects due to a stronger U.S. Dollar relative to our other functional currencies of \$10,217. On a constant currency basis and net of the impact from adopting Topic 606, our revenues from EMEA increased by 6.0% for the year ended December 31, 2019 as compared to the prior period.

The increase in organic performance was primarily due to expansion of our recurring revenues throughout the region. Approximately 50% of our organic performance expansion was driven by ProjectWise and Offshore Structural Analysis products.

The negative impact from acquisition integration relates to a 2018 acquisition. In 2018 we recognized perpetual license revenues from this acquisition of \$4,061. License revenues were recognized upon delivery. Upon completing acquisition integration and beginning in 2019, such license sales were subject to our SELECT subscription program, including the portfolio balancing performance obligation. As a result, beginning in 2019 we would have recognized such license revenues ratably over a three-year period under Topic 605. In connection with this acquisition, we sold \$6,317 of licenses in 2019, of which \$823 was ratably recognized in 2019 and the balance of \$5,494 was deferred under Topic 605. For comparison purposes, under Topic 606, revenue of \$6,317 was recognized upon delivery in 2019.

- *APAC.* Net of the increase from adopting Topic 606 of \$5,060, revenues from APAC increased by \$7,186, or 5.5%, for the year ended December 31, 2019 as compared to the year ended December 31, 2018. This increase was driven primarily by improvements in our organic performance of \$11,169 and, to a lesser extent, the impact from acquisitions of \$750, partially offset by negative foreign currency effects due to a stronger U.S. Dollar relative to our other functional currencies of \$4,733. On a constant currency basis and net of the impact from adopting Topic 606, our revenues from APAC increased by 9.1% for the year ended December 31, 2019 as compared to the prior period.

The increase in organic performance was primarily due to expansion of our recurring revenues from our existing accounts in Australia and China. Approximately 50% of our organic performance expansion was driven by ProjectWise and civil design products.

*Cost of Revenues*

	Year Ended December 31,		Comparison					
	2018	2019	Amount	%	Impact from Adoption of Topic 606	Remaining Difference	%	Constant Currency %
	As reported Topic 605	As reported Topic 606						
Cost of subscriptions and licenses	\$ 55,113	\$ 71,578	\$16,465	29.9%	\$139	\$ 16,326	29.6%	32.8%
Cost of services	76,211	72,572	(3,639)	(4.8)%	—	(3,639)	(4.8)%	(2.2)%
Total cost of revenues	<u>\$ 131,324</u>	<u>\$ 144,150</u>	<u>\$12,826</u>	9.8%	<u>\$139</u>	<u>\$ 12,687</u>	9.7%	12.5%

For the year ended December 31, 2019, cost of revenues reported under Topic 606 increased by \$12,826, or 9.8%, to \$144,150 as compared to cost of revenues reported under Topic 605 for the year ended December 31, 2018. This increase was driven primarily by an increase in cost of subscriptions and licenses, partially offset by lower cost of services relative to the prior period. Cost of revenues has not been significantly impacted by the adoption of Topic 606.

Net of the increase from adopting Topic 606 of \$139, cost of subscriptions and licenses increased 29.6%, or 32.8% in constant currency, as compared to the year ended December 31, 2018. On a constant currency basis, this increase was primarily due to an increase in hosting costs of approximately \$6,600, an increase in salaries, incentive compensation, and other headcount-related costs of approximately \$6,000, an increase in amortization expense of approximately \$1,500 related to certain projects under our Accelerated Commercial Development Program, an increase in reseller costs of approximately \$1,900 and an increase in amortization expense of approximately \$1,000 for software and technology.

Cost of services decreased by 4.8%, or 2.2% in constant currency, as compared to the year ended December 31, 2018. On a constant currency basis, the decrease was primarily due to a decrease in salaries, incentive compensation, and other headcount-related costs of approximately \$1,100 as well as a decrease in the recognition of previously capitalized costs related to certain professional services projects of approximately \$500.

*Operating Expenses*

	Year Ended December 31,		Comparison					
	2018	2019	Amount	%	Impact from Adoption of Topic 606	Remaining Difference	%	Constant Currency %
	As reported Topic 605	As reported Topic 606						
Research and development	\$ 175,032	\$ 183,552	\$ 8,520	4.9%	\$—	\$ 8,520	4.9%	7.2%
Selling and marketing	160,635	155,294	(5,341)	(3.3)%	20	(5,361)	(3.3)%	(1.0)%
General and administrative	89,328	97,580	8,252	9.2%	—	8,252	9.2%	10.6%
Amortization of purchased intangibles	14,000	14,213	213	1.5%	—	213	1.5%	4.4%
Total operating expenses	<u>\$ 438,995</u>	<u>\$ 450,639</u>	<u>\$11,644</u>	2.7%	<u>\$20</u>	<u>\$ 11,624</u>	2.6%	4.8%

*Research and development.* Research and development expenses increased 4.9%, or 7.2% in constant currency, as compared to the year ended December 31, 2018. On a constant currency basis, the increase was primarily due to an increase in salaries, incentive compensation, and other headcount-related costs of approximately \$8,800, as well as an increase in facility-related costs of approximately \$3,300.

*Selling and marketing.* Selling and marketing expenses decreased 3.3%, or 1.0% in constant currency, as compared to the year ended December 31, 2018. The decrease is primarily caused by a reduction in sales incentives, which were at an elevated level for the year ended December 31, 2018.

*General and administrative.* General and administrative expenses increased 9.2%, or 10.6% in constant currency, as compared to the year ended December 31, 2018. On a constant currency basis, the increase was primarily caused by an increase in salaries, incentive compensation, and other headcount-related costs of approximately \$8,600, as well as approximately \$900 related to incremental accounting costs associated with this offering.

*Amortization of purchased intangibles.* Amortization of purchased intangibles increased by 1.5%, or 4.4% in constant currency, as compared to the year ended December 31, 2018. The increase was primarily attributable to acquisitions that closed in 2018.

#### *Interest Expense, Net*

	Year Ended December 31,	
	2018	2019
Interest expense	\$(9,607)	\$(9,731)
Interest income	842	1,532
Total interest expense, net	<u>\$(8,765)</u>	<u>\$(8,199)</u>

	Year Ended December 31,	
	2018	2019
Bank credit facility	\$(8,800)	\$(8,971)
Amortization of deferred financing costs	(552)	(553)
Other, net	587	1,325
Total interest expense, net	<u>\$(8,765)</u>	<u>\$(8,199)</u>

Our net interest expense for the year ended December 31, 2019 decreased from the prior year period primarily due to an offsetting increase in interest income from our investments in money market funds.

#### *Other Income (Expense), Net*

	Year Ended December 31,	
	2018	2019
Foreign exchange loss	\$(418)	\$(5,591)
Other income, net	654	34
Total other income (expense), net	<u>\$ 236</u>	<u>\$(5,557)</u>

Other income (expense), net for the years ended December 31, 2018 and 2019 primarily consists of foreign currency translation losses of \$418 and \$5,591, respectively. The foreign currency translation losses derive primarily from U.S. Dollar denominated intercompany balances, cash and cash equivalents, and accounts receivable held by foreign subsidiaries with non-U.S. Dollar functional currencies. In October 2018, we had intercompany sales of certain intangible operating assets between our foreign subsidiaries, which resulted in significant U.S. Dollar denominated intercompany liabilities at foreign subsidiaries with a non-U.S. Dollar functional currency (mainly Euro). These U.S. Dollar denominated balances are being translated into their functional currencies at the rates in effect at the balance sheet date and fully eliminate in consolidation. The gains and losses from such translations are included in *Other income (expense), net*. For the year ended December 31, 2019, such intercompany balances resulted in unrealized foreign currency translation losses of \$5,270.

#### *Provision for Income Taxes*

The income tax provisions for the years ended December 31, 2018 and 2019 were based on the effective income tax rates applicable for those periods. During the years ended December 31, 2018 and 2019, we

recognized an aggregate consolidated income tax (benefit) expense of \$(29,250) and \$23,738, respectively, for U.S. domestic and foreign income taxes. The effective income tax rate of (25.9)% for the year ended December 31, 2018 was primarily impacted by a non-recurring tax benefit of \$46,369 resulting from an intercompany sale of certain intangible operating assets. The effective income tax rate of 18.5% for the year ended December 31, 2019 was primarily a result of the timing and mix of U.S. and foreign income. The provision for income tax under Topic 605 would have been \$21,762 for the year ended December 31, 2019.

#### *Equity in Loss of Joint Venture, Net of Tax*

In September 2019, we and Topcon Positioning Systems, Inc. formed Digital Construction Works, Inc. (“DCW”), a joint venture that operates as a digital integrator of software and cloud services for the construction industry. DCW’s focus is to transform the construction industry from its legacy document-centric paradigm by simplifying and enabling digital automated workflows and processes, technology integration, and digital twinning services for infrastructure.

We have a 50% ownership in DCW and apply the equity method of accounting for our investment in DCW. Under the equity method, we recorded our initial investment in the joint venture at cost and subsequently adjust that investment by our proportional share of income or losses in DCW. For the year ended December 31, 2019, the equity in loss, net of tax, related to the investment was \$1,275.

#### *Net Income*

	Year Ended December 31,		
	2018	2019	
	Topic 605	Topic 605	Topic 606
Net income	\$142,112	\$103,426	\$103,096

For the year ended December 31, 2019, net income under Topic 606 decreased by \$39,016, or 27.5% (\$38,686, or 27.2%, under Topic 605), compared to the year ended December 31, 2018 under Topic 605. The change is due to the factors stated above.

#### *Adjusted EBITDA and Adjusted Net Income*

	Year Ended December 31,		
	2018	2019	
	Topic 605	Topic 605	Topic 606
Adjusted EBITDA	\$171,768	\$186,598	\$188,129
Adjusted Net Income	\$132,246	\$135,471	\$135,049

For the year ended December 31, 2019, Adjusted EBITDA under Topic 606 increased by \$16,361 (or \$14,830 under Topic 605) compared to the year ended December 31, 2018 under Topic 605. These increases were primarily due to an increase in income from operations, net of adjustments discussed in the section titled “Selected Consolidated Financial Data.” The larger increase under Topic 606 is primarily driven by the upfront recognition of perpetual license revenue under Topic 606 as compared to ratable recognition over a three-year period under Topic 605, partially offset by lower subscription revenue due to ELS to E365 conversions. For additional information, see the section titled “— Key Factors Impacting Comparability and Performance.”

Under Topic 605, Adjusted EBITDA as a percentage of revenue was 24.8% and 25.4% for the years ended December 31, 2018 and 2019, respectively. Under Topic 606, Adjusted EBITDA as a percentage of revenue was 25.5% for the year ended December 31, 2019.

For the year ended December 31, 2019, Adjusted Net Income under Topic 606 increased by \$2,803 (or \$3,225 under Topic 605) compared to the year ended December 31, 2018 under Topic 605. These increases were primarily due to an increase in income from operations net of adjustments discussed in the section titled “Selected Consolidated Financial Data.” The increase in Adjusted Net Income under Topic 606, when compared to Topic 605, was positively impacted by the upfront recognition of perpetual license revenue as

compared to ratable recognition over a three-year period under Topic 605. This increase was offset by lower subscription revenue due to ELS to E365 conversions and a slightly higher provision for income taxes under Topic 606 when compared to Topic 605.

Under Topic 605, Adjusted Net Income as a percentage of revenue was 19.1% and 18.4% for the years ended December 31, 2018 and 2019, respectively. Under Topic 606, Adjusted Net Income as a percentage of revenue was 18.3% for the year ended December 31, 2019.

For additional information, including the limitations of using non-GAAP financial measures, and reconciliations of the non-GAAP financial measures to the most directly comparable financial measures stated in accordance with U.S. GAAP, see the section titled “Selected Consolidated Financial Data — Non-GAAP Financial Measures.”

**Quarterly Results of Operations:**

The following table sets forth our quarterly unaudited consolidated statements of operations for each of the quarters in the ten-quarter period ended June 30, 2020. Our quarterly results of operations have been prepared on the same basis as our audited consolidated financial statements, and we believe they reflect all normal recurring adjustments necessary for the fair presentation of our results of operations for these periods. This information should be read in conjunction with our consolidated financial statements and related notes included elsewhere in the prospectus. These quarterly results of operations are not necessarily indicative of our results of operations for a full year or any future period. Results of operations for the four quarters in the year ended December 31, 2018 are presented under Topic 605 while the four quarters in the year ended December 31, 2019 and the two quarters in the period ended June 30, 2020 are presented under Topic 606.

	Q1 2018	Q2 2018	Q3 2018	Q4 2018	Q1 2019	Q2 2019	Q3 2019	Q4 2019	Q1 2020	Q2 2020
<b>Revenues:</b>										
Subscriptions	\$137,807	\$139,013	\$137,881	\$142,720	\$152,309	\$137,838	\$155,191	\$162,962	\$170,182	\$157,655
Perpetual licenses	14,860	15,846	15,443	14,916	9,409	15,059	13,787	21,438	10,814	12,379
Subscriptions and licenses	152,667	154,859	153,324	157,636	161,718	152,897	168,978	184,400	180,996	170,034
Services	16,750	19,200	18,160	19,114	15,821	16,708	17,610	18,522	13,694	14,256
Total revenues	169,417	174,059	171,484	176,750	177,539	169,605	186,588	202,922	194,690	184,290
<b>Cost of revenues:</b>										
Cost of subscriptions and licenses	12,892	12,454	15,450	14,317	14,342	16,489	17,370	23,377	21,327	21,801
Cost of services	17,267	22,432	17,768	18,744	18,225	20,142	17,681	16,524	15,932	14,904
Total cost of revenues	30,159	34,886	33,218	33,061	32,567	36,631	35,051	39,901	37,259	36,705
Gross profit	139,258	139,173	138,266	143,689	144,972	132,974	151,537	163,021	157,431	147,585
<b>Operating expenses:</b>										
Research and development	40,983	43,822	42,793	47,434	44,477	47,384	44,756	46,935	45,135	44,218
Selling and marketing	35,886	39,047	38,235	47,467	35,982	39,186	36,721	43,405	36,095	29,632
General and administrative	20,906	23,414	22,171	22,837	22,804	23,503	25,108	26,165	26,804	25,465
Amortization of purchased intangibles	2,341	3,662	3,958	4,039	3,420	3,432	3,550	3,811	3,436	3,679
Total operating expenses	100,116	109,945	107,157	121,777	106,682	113,506	110,135	120,316	111,470	102,994
Income from operations	39,142	29,228	31,109	21,912	38,290	19,468	41,402	42,705	45,961	44,591
Interest expense, net	(1,839)	(2,248)	(2,276)	(2,402)	(2,282)	(2,192)	(2,029)	(1,696)	(1,388)	(1,128)
Other income (expense), net	(1,244)	(245)	(477)	2,202	(5,253)	3,506	(12,306)	8,496	(7,390)	405
Income before income taxes	36,059	26,735	28,356	21,712	30,755	20,782	27,067	49,505	37,183	43,868
Provision for income taxes	4,780	1,543	5,052	(40,625)	4,318	801	6,640	11,979	7,176	4,264
Equity in loss of joint venture, net of tax	—	—	—	—	—	—	—	1,275	338	528
Net income	\$ 31,279	\$ 25,192	\$ 23,304	\$ 62,337	\$ 26,437	\$ 19,981	\$ 20,427	\$ 36,251	\$ 29,669	\$ 39,076

On January 1, 2019, we adopted Topic 606, which supersedes substantially all existing revenue recognition guidance under U.S. GAAP. We adopted Topic 606 using the modified retrospective method, under which the cumulative effect of initially applying Topic 606 was recorded as a reduction to the opening balance of *Accumulated deficit* as of January 1, 2019. We applied the standard only to contracts that were not completed as of the date of initial application. The comparative information for each of the four quarters in the year ended December 31, 2018 has not been adjusted and continues to be reported under Topic 605.

	Q1 2018	Q2 2018	Q3 2018	Q4 2018	Q1 2019	Q2 2019	Q3 2019	Q4 2019
<b>Revenues (Topic 605):<sup>(1)</sup></b>								
Subscriptions	\$137,807	\$139,013	\$137,881	\$142,720	\$146,372	\$149,360	\$154,225	\$163,968
Perpetual licenses	14,860	15,846	15,443	14,916	12,954	12,857	13,088	13,620
Subscriptions and licenses	152,667	154,859	153,324	157,636	159,326	162,217	167,313	177,588
Services	16,750	19,200	18,160	19,114	15,851	16,963	16,430	19,161
Total revenues	<u>\$169,417</u>	<u>\$174,059</u>	<u>\$171,484</u>	<u>\$176,750</u>	<u>\$175,177</u>	<u>\$179,180</u>	<u>\$183,743</u>	<u>\$196,749</u>
<b>Revenues (Topic 606):<sup>(2)</sup></b>								
Subscriptions	\$141,902	\$133,141	\$138,194	\$147,248	\$152,309	\$137,838	\$155,191	\$162,962
Perpetual licenses	12,639	14,116	11,682	18,916	9,409	15,059	13,787	21,438
Subscriptions and licenses	154,541	147,257	149,876	166,164	161,718	152,897	168,978	184,400
Services	16,750	19,200	18,160	19,114	15,821	16,708	17,610	18,522
Total revenues	<u>\$171,291</u>	<u>\$166,457</u>	<u>\$168,036</u>	<u>\$185,278</u>	<u>\$177,539</u>	<u>\$169,605</u>	<u>\$186,588</u>	<u>\$202,922</u>

- (1) The amounts presented for the four quarters ended December 31, 2019 give effect to revenue adjustment as if the adoption of Topic 606 had not occurred on January 1, 2019. For a reconciliation of the impact of adopting Topic 606 on our audited consolidated financial statements for the year ended December 31, 2019, see Note 2 to our consolidated financial statements included elsewhere in this prospectus.
- (2) The amounts presented for the four quarters in the year ended December 31, 2018 are unaudited and give effect to revenue adjustments as if the adoption of Topic 606 had occurred as of January 1, 2018 rather than January 1, 2019. The most significant impact from the adoption of Topic 606 relates to timing of revenue recognition for perpetual licenses and the accounting for certain of our subscription arrangements that include term-based software licenses bundled with support. Under the prior guidance, revenue for perpetual licenses was recognized over a three-year period, while revenue attributable to the term-based software licenses was recognized ratably over the term. Under Topic 606, both perpetual license and prepaid term-based software license revenue will be recognized upfront upon delivery of the software license. Our revenue recognition for services remained substantially unchanged and was not adjusted. See Note 2 to our consolidated financial statements included elsewhere in this prospectus for additional information regarding the adoption of Topic 606.

Reconciliation of Topic 605 to Topic 606:

	Three Months Ended March 31, 2018		
	As reported Topic 605	Adjustments	Topic 606
Subscriptions	\$137,807	\$ 4,095	\$141,902
Perpetual licenses	14,860	(2,221)	12,639
	Three Months Ended June 30, 2018		
	As reported Topic 605	Adjustments	Topic 606
Subscriptions	\$139,013	\$(5,872)	\$133,141
Perpetual licenses	15,846	(1,730)	14,116
	Three Months Ended September 30, 2018		
	As reported Topic 605	Adjustments	Topic 606
Subscriptions	\$137,881	\$ 313	\$138,194
Perpetual licenses	15,443	(3,761)	11,682

	<b>Three Months Ended December 31, 2018</b>		
	<b>As reported Topic 605</b>	<b>Adjustments</b>	<b>Topic 606</b>
Subscriptions	\$ 142,720	\$4,528	\$147,248
Perpetual licenses	14,916	4,000	18,916

**Quarterly Trends:**

A portion of our revenues and operating expenses were derived from outside the United States and as such, were denominated in various foreign currencies, including most significantly: Euros, British Pounds, Australian Dollars, Canadian Dollars, and Chinese Yuan Renminbi. Our quarterly results are therefore impacted by changes in foreign currency rates. Starting in the quarter ended March 31, 2018, and continuing into the quarter ended June 30, 2020, the U.S. Dollar strengthened relative to other foreign currencies in which we generate revenues and incur expenses. However, towards the end of the quarter ended June 30, 2020, the U.S. Dollar began to weaken relative to other foreign currencies in which we generate revenues and incur expenses. Accordingly, our results of operations have been, and in the future will be, affected by changes in foreign exchange rates. See the section titled “Key Factors Impacting Comparability and Performance — Impact of foreign currency.”

**Revenues:**

Our revenues are primarily comprised of recurring subscription revenues. Historically, we have experienced growth in subscription revenues within existing accounts when their contracts renew, and typically, we have a higher level of renewals occur in the first and fourth quarter of each year. This renewal cycle is primarily based on the timing of when accounts first entered into their subscription contracts. Under Topic 605, subscription revenues were recognized on a ratable basis over the subscription term and generally showed an increase in each period presented. Under Topic 606, our quarterly subscriptions revenues and profitability are impacted by the subscription term as well as the term start date of new and renewals subscriptions, due to the upfront revenue recognition of the associated term license component. Topic 606 therefore introduces volatility between quarters with our first and fourth quarter generally showing higher subscription revenues. However, on an annual and trailing twelve-month basis, we generally expect our subscription revenues recognized under Topic 606 to be comparable to such revenues recognized under Topic 605. This is attributable to the annual, recurring nature of our subscription agreements.

The conversion of our existing subscription users to consumption-based offerings with consumption measurement durations of less than one year, such as our E365 program, will further introduce some volatility between annual, quarterly, and trailing twelve-month periods and impact period over period comparability under Topic 606. This is because the term-based software license is recognized upfront upon delivery for subscription-based offerings, but upon usage for prepaid consumption-based offerings. See the section titled “— Key Factors Impacting Comparability and Performance.”

Under Topic 605, revenue for perpetual licenses was recognized over a three-year period, due to the portfolio balancing feature users obtain through their SELECT subscriptions. Under Topic 606, our perpetual licenses revenues are recognized upon delivery and will closely align with the respective license sales of the period. Typically, we have a higher level of perpetual license sales in the fourth quarter of each year.

Our quarterly revenue for professional services may also fluctuate depending on the timing of our accounts requests for additional services and the related implementation cycles.

Increases in organic revenues over the ten quarters presented were offset by negative foreign currency impacts due to a stronger U.S. Dollar relative to our other functional currencies.

**Headcount-related costs:**

For the year ended December 31, 2019, 80% of our aggregate cost of revenues, research and development, selling and marketing, and general and administrative costs were represented by what we refer to herein as “headcount-related” costs. These costs include the salary costs of our colleagues (our



employees) and the corresponding incentives, benefits, employment taxes, and travel-related costs. Our headcount-related costs are variable in nature. We actively manage these costs to align to our trending run rate of revenue performance, with the objective of enhancing visibility to better predict the resulting operating profit margins.

Our quarterly operating expenses are impacted by the timing of headcount adjustments including additions from acquisitions and realignment programs, the timing of annual raises and variable compensation, product development cycles, and sales and marketing programs. We experience some seasonality in spending related to sales and marketing based on the timing of our participation in certain trade shows and conferences. Typically, we incur higher sales and marketing expenses during the fourth quarter of each year. We cannot assure you, however, that these trends will continue.

Our aggregate cost of revenues, research and development, selling and marketing, and general and administrative costs increased over the ten quarters presented and were partly offset by foreign currency impacts due to a stronger U.S. Dollar relative to our other functional currencies.

***Liquidity and Capital Resources:***

Our primary source of cash is generated from the delivery of subscriptions, perpetual licenses, and services. Our primary use of cash is payment of our operating costs, which consist primarily of colleague-related expenses, such as compensation and benefits, as well as general operating expenses for marketing, facilities, and overhead costs. In addition to operating expenses, we also use cash to fund growth initiatives, which include acquisitions of software assets and businesses.

Our cash and cash equivalent balances are concentrated in a few locations around the world, with substantial amounts held outside of the United States. As of December 31, 2018 and 2019, 95% and 98%, respectively, of our total cash and cash equivalents were located outside of the United States. As of June 30, 2020, 72% of our total cash and cash equivalents were located outside of the United States. Under the Tax Cuts and Jobs Act, we are subject to U.S. taxes for the deemed repatriation of certain cash balances held by foreign corporations. We intend to continue to permanently reinvest these funds outside of the United States, and current plans do not demonstrate a need to repatriate them to fund our U.S. operations. We expect to meet our U.S. liquidity needs through ongoing cash flows or external borrowings including available liquidity under the Credit Facility described below. We regularly review our capital structure and consider a variety of potential financing alternatives and planning strategies to ensure that we have the proper liquidity available in the locations in which it is needed and to fund our operations and growth investments with cash that has not been permanently reinvested outside the United States.

We believe that existing cash and cash equivalent balances, together with cash generated from operations and liquidity under the Credit Facility, will be sufficient to meet our domestic and international working capital and capital expenditure requirements through the next twelve months. However, our future capital requirements may be materially different than those currently planned in our budgeting and forecasting activities and depend on many factors, including our rate of revenue growth, the timing and extent of spending on research and development, the expansion of our sales and marketing activities, the timing of new product introductions, currency fluctuations, market acceptance of our products, competitive factors, and overall economic conditions, globally. To the extent that current and anticipated future sources of liquidity are insufficient to fund our future business activities and requirements, we may be required to seek additional equity or debt financing. The sale of additional equity would result in additional dilution to our shareholders, while the incurrence of debt financing, including convertible debt, would result in debt service obligations. Such debt instruments also could introduce covenants that might restrict our operations. We cannot assure you that we could obtain additional financing on favorable terms or at all. See the section titled “Risk Factors — Risks Related to Our Business — We may need to raise additional capital, which may not be available to us.”

*Cash and cash equivalents.* We consider all highly liquid investments with an original maturity of three months or less at the date of purchase to be cash equivalents. Our cash and cash equivalents consisted of cash held in checking accounts and money market funds maintained at various financial institutions. The following table presents our foreign and domestic holdings of cash and cash equivalents:

	December 31,		June 30,
	2018	2019	
Cash and cash equivalents:			
Held domestically	\$ 3,788	\$ 2,291	\$ 34,653
Held by foreign subsidiaries	<u>77,395</u>	<u>118,810</u>	<u>90,863</u>
Total cash and cash equivalents	<u>\$81,183</u>	<u>\$121,101</u>	<u>\$125,516</u>

The amount of cash and cash equivalents held by foreign subsidiaries is subject to translation adjustments caused by changes in foreign currency exchange rates as of the end of each respective reporting period, the offset to which is recorded in accumulated other comprehensive loss on our consolidated balance sheet.

*Bank Credit Facility.* On December 19, 2017, we entered into the Credit Facility, which matures on December 18, 2022. Upon entry into this agreement, we obtained a \$500,000 senior secured revolving facility and refinanced all indebtedness outstanding under our prior facility.

In addition to the revolving line of credit, the Credit Facility also provides up to \$50,000 of letters of credit and other incremental borrowings subject to availability, including a \$50,000 multi-currency swing-line sub-facility and a \$100,000 incremental “accordion” sub-facility. We had \$631, \$546, and \$150 of letters of credit and surety bonds outstanding as of December 31, 2018, December 31, 2019, and June 30, 2020, respectively. We had \$240,619, \$265,704, and \$292,850 available under the Credit Facility as of December 31, 2018, December 31, 2019, and June 30, 2020, respectively.

On September 2, 2020, we entered into the First Amendment to the Credit Facility. The First Amendment provided the New Term Loan of \$125.0 million with a maturity of December 18, 2022 and included certain other amendments, including the addition of a mandatory prepayment provision requiring us to prepay borrowings under the Credit Facility in an aggregate amount equal to the net proceeds from any underwritten public offering by the Company, which prepayment shall be applied, first, to the New Term Loan and, second, to any borrowings outstanding under the revolving facility under the Credit Facility without reducing the revolving commitments thereof. We used borrowings under the New Term Loan and under the revolving facility under the Credit Facility to pay the Special Dividend of \$1.50 per share of our common stock (approximately \$390 million in the aggregate) and a regular quarterly dividend of \$0.03 per share of our common stock. See the section titled “Prospectus Summary — Recent Developments — New Term Loan and Payment of Special Dividend.”

Under the Credit Facility, we may make either Euro currency or non-Euro currency interest rate elections. Interest on the Euro currency borrowings is at the one-month LIBOR plus a spread ranging from 100 basis points (“bps”) to 225 bps as determined by our net leverage ratio. Under the non-Euro currency elections, Credit Facility borrowings bear a base interest rate of the greater of (i) the prime rate, (ii) the overnight bank funding effective rate plus 50 bps, or (iii) LIBOR plus 100 bps, plus a spread ranging from 0 bps to 125 bps as determined by our leverage ratio. In addition, a commitment fee for the unused Credit Facility ranges from 15 bps to 30 bps as determined by our net leverage ratio.

Borrowings under the Credit Facility are guaranteed by all of our first-tier domestic subsidiaries and are secured by a first priority security interest in substantially all of our and the guarantors’ U.S. assets and 65% of the stock of their directly owned foreign subsidiaries. The agreement governing the Credit Facility contains both affirmative and negative covenants, including maximum leverage ratios. At December 31, 2018, December 31, 2019, and June 30, 2020, we were in compliance with all covenants in our Credit Facility.

Interest rate risk associated with the Credit Facility is managed through an interest rate swap that we executed on March 31, 2020. The swap has an effective date of April 2, 2020 and a termination date of April 2, 2030. Under the terms of the swap, we fixed our LIBOR borrowing rate at 0.73% on a notional amount of \$200,000. The interest rate swap is not designated as a hedging instrument for accounting purposes. We account for the swap as either an asset or a liability on the balance sheet and carry the derivative at fair value. Gains and losses from the change in fair value are recognized in Other income (expense), net, in the consolidated statements of operations. At June 30, 2020, the fair value of the swap was \$4,174.

For the years ended December 31, 2018 and 2019, the weighted average interest rate under the Credit Facility was 3.28% and 3.47%, respectively. As of December 31, 2018, accrued interest and fees were \$31. Interest expense was \$8,800 and \$8,971 for the years ended December 31, 2018 and 2019, respectively.

For the six months ended June 30, 2019 and 2020, the weighted average interest rate under the Credit Facility was 3.73% and 2.18%, respectively. As of June 30, 2020, accrued interest and fees were \$33. Interest expense was \$4,600 and \$2,544 for the six months ended June 30, 2019 and 2020, respectively.

In addition, interest expense includes amortization of deferred financing costs of \$552 and \$553 for the years ended December 31, 2018 and 2019, respectively and \$277 for each of the six months ended June 30, 2019 and 2020.

The agreement governing the Credit Facility contains customary events of default, including, without limitation, payment defaults, breaches of representations and warranties, covenants defaults, cross-defaults to certain other indebtedness in excess of \$10,000, certain events of bankruptcy and insolvency, judgment defaults in excess of \$10,000, failure of any security document supporting the Credit Facility to be in full force and effect, and a change of control.

Voluntary prepayments of amounts outstanding under the Credit Facility, in whole or in part, are permitted at any time, so long as we give notice as required by the Credit Facility. However, if prepayment is made with respect to a LIBOR-based loan and the prepayment is made on a date other than an interest payment date, we must pay customary breakage costs.

This summary of the terms of the Credit Facility is qualified in its entirety by reference to the agreement, which is filed as an exhibit to the registration statement of which this prospectus forms a part.

#### ***Comparison of the Six Months Ended June 30, 2019 and 2020***

The following table summarizes our cash flow activities for the six months ended June 30, 2019 and 2020:

	<b>Six Months Ended June 30,</b>	
	<b>2019</b>	<b>2020</b>
<b>Net Cash Provided By (Used In):</b>		
Operating activities	\$ 82,758	\$136,182
Investing activities	\$(18,157)	\$(78,979)
Financing activities	\$(42,004)	\$(52,556)

#### ***Operating activities:***

For the six months ended June 30, 2019, net cash provided by operating activities were \$82,758 primarily due to net income of \$46,418 increased by \$22,024 of non-cash adjustments and \$14,316 from changes in operating assets and liabilities.

Net cash provided by operating activities was \$136,182 during the six months ended June 30, 2020. Compared to the prior year comparative period, net cash from operating activities was higher by \$53,424 due to an increase in net income of \$22,327, a net increase in non-cash adjustments of \$12,527, and an increase in net cash flows from the change in operating assets and liabilities of \$18,570. The net increase in non-cash adjustments primarily related to a \$1,298 increase in depreciation and amortization, an increase of \$7,638 in deferred income taxes, an increase of \$4,015 related to the change in the fair value of the interest rate swap, and an increase of \$2,308 related to foreign currency remeasurement losses. The net increase in cash flows from changes in operating assets and liabilities of \$18,570 was due to increased cash flows related to the collection of accounts receivable, net of \$4,407, an increase from the change in prepaid and other assets of \$16,586, and an increase from the change in income taxes payable of \$9,990, offset by a decrease from the change in accounts payable, accruals and other liabilities of \$8,239 and a decrease from the change in deferred revenues of \$4,174.

**Investing activities:**

For the six months ended June 30, 2019, net cash used in investing activities was \$18,157, primarily due to \$8,123 related to purchases of property and equipment and investment in capitalized software and \$9,662 in acquisition related payments, net of cash acquired.

Net cash used in investing activities was \$78,979 during the six months ended June 30, 2020, primarily due to \$9,419 related to purchases of property and equipment and investment in capitalized software and \$67,595 in acquisition related payments, net of cash acquired.

**Financing activities:**

For the six months ended June 30, 2019, net cash used in financing activities was \$42,004, primarily due to net payments under the Credit Facility of \$11,750, payment of a contingent acquisition liability of \$8,273, payments of dividends of \$12,641, and net payments for shares acquired of \$11,517.

Net cash used in financing activities was \$52,556 during the six months ended June 30, 2020. Compared to the prior year comparative period, net cash used in financing activities increased by \$10,552, primarily due to an increase in net repayments of \$15,000 under the Credit Facility and an increase in payments for dividends of \$3,260, partly offset by a decrease in the payment of acquisition debt and other consideration of \$7,182, and a decrease in net payments for share repurchases of \$559.

**Comparison of the Years Ended December 31, 2018 and 2019**

The following table summarizes our cash flow activities for the periods indicated:

	<b>Year Ended December 31,</b>	
	<b>2018</b>	<b>2019</b>
<b>Net Cash Provided By (Used In):</b>		
Operating activities	\$ 161,465	\$170,773
Investing activities	(154,757)	(53,693)
Financing activities	(58,799)	(77,048)

**Operating activities:**

For the year ended December 31, 2018, net cash provided by operating activities was \$161,465, due to net income of \$142,112 increased by \$43,464 of non-cash adjustments and \$35,949 from changes in operating assets and liabilities, offset by \$60,060 of non-cash tax benefits.

Net cash provided by operating activities was \$170,773 during the year ended December 31, 2019. Compared to the prior year comparative period, net cash from operating activities was higher by \$9,308 due to a net increase in non-cash adjustments of \$69,795, offset by a decrease in net income of \$39,016 and a decrease from changes in operating assets and liabilities of \$21,471. The net increase in non-cash adjustments primarily related to a \$60,792 increase in deferred income taxes as well as an increase of \$6,956 related to foreign currency remeasurement losses. The net decrease in cash flows from changes in operating assets and liabilities of \$21,471 was primarily due to decrease in deferred revenues of \$21,515, a decrease from the changes in income taxes payable of \$21,723, partially offset by the decreased collection of accounts receivable, net of \$20,635 and an increase from the change in accounts payable, accruals and other liabilities of \$4,631.

**Investing activities:**

For the year ended December 31, 2018, net cash used in investing activities was \$154,757, primarily due to \$18,616 related to purchases of property and equipment and investment in capitalized software and \$135,264 in acquisition related payments, net of cash acquired.

Net cash used in investing activities was \$53,693 during the year ended December 31, 2019, primarily due to \$15,804 related to purchases of property and equipment and investment in capitalized software and \$34,054 in acquisition related payments, net of cash acquired.

**Financing activities:**

For the year ended December 31, 2018, net cash used in financing activities was \$58,799, primarily due to net repayments under the Credit Facility of \$11,250, payments of dividends of \$20,059, and net payments for shares acquired of \$30,231.

Net cash used in financing activities was \$77,048 during the year ended December 31, 2019. Compared to the prior year comparative period, net cash used in financing activities increased by \$18,249, primarily due to an increase in net repayments of \$13,750 under the Credit Facility, an increase in the payment of acquisition debt and other consideration of \$11,038, and an increase in payments for dividends of \$4,930, partially offset by a decrease in net payments for share repurchases of \$10,575.

**Contractual Obligations and Other Commitments:**

The following table represents our contractual commitments as of December 31, 2019. The information presented in the table below reflects management's estimates of the contractual maturities of our obligations. These maturities may differ from the actual maturities of these obligations.

	Payments Due By Period				
	Total	Within 1 Year	1 – 3 Years	3 – 5 Years	After 5 Years
Long-term debt <sup>(1)</sup>	\$233,750	\$ —	\$233,750	\$ —	\$ —
Interest on long-term debt <sup>(1)</sup>	24,066	8,111	15,955	—	—
Operating lease obligations <sup>(2)</sup>	52,016	15,886	23,571	9,788	2,771
Deferred compensation obligations <sup>(3)</sup>	2,544	153	358	438	1,595
Contingent obligations <sup>(4)</sup>	6,599	5,100	1,499	—	—
Non-contingent obligations <sup>(5)</sup>	900	900	—	—	—
<b>Total contractual obligations</b>	<b>\$319,875</b>	<b>\$30,150</b>	<b>\$275,133</b>	<b>\$10,226</b>	<b>\$4,366</b>

- (1) Long-term debt represents the outstanding balance of \$233,750 related to the Credit Facility with an effective interest rate of 3.47%.
- (2) Operating lease obligations include non-cancellable operating lease commitments for our domestic and international facilities, cars, and equipment.
- (3) Deferred compensation obligations relate to the deferred portion of bonus compensation of certain former colleagues.
- (4) Contingent consideration from acquisitions.
- (5) Non-contingent consideration from acquisitions.

**Critical Accounting Policies and Use of Estimates:**

Our consolidated financial statements are prepared in conformity with U.S. GAAP. In preparing our consolidated financial statements, we make assumptions, judgments, and estimates that can have a significant impact on amounts reported in the consolidated financial statements. We base our assumptions, judgments, and estimates on historical experience and various other factors that we believe to be reasonable under the circumstances. Actual results could differ materially from these estimates under different assumptions or conditions. We regularly reevaluate our assumptions, judgments, and estimates. Our significant accounting policies are described in Note 1 to our consolidated financial statements included elsewhere in this prospectus. We believe that the following critical accounting policies affect the more significant judgments and estimates used in the preparation of our consolidated financial statements.

**Revenue recognition**

On January 1, 2019, we adopted Topic 606, using the modified retrospective method, under which the cumulative effect of initially applying Topic 606 of \$125,464 (\$101,489 net of tax) was recorded as a reduction

to the opening balance of *Accumulated deficit*. The impact from adoption was primarily derived from the timing of revenue recognition of perpetual licenses and the accounting for certain of our subscription arrangements that include term-based software licenses bundled with support. Under the prior guidance, revenue for perpetual licenses was recognized over a three-year period, while revenue attributable to the term-based software licenses was recognized ratably over the term. Under Topic 606, both perpetual license and prepaid term-based software license revenue will be recognized upfront upon delivery of the software license. The comparative information has not been adjusted and continues to be reported under Topic 605. Refer to Note 2, Recent Accounting Pronouncements, in our consolidated financial statements for a qualitative and quantitative discussion of the adoption impact.

Topic 606 establishes a principle for recognizing revenue upon the transfer of promised goods or services to customers, in an amount that reflects the expected consideration received in exchange for those goods or services.

We generate revenues from subscriptions, perpetual licenses, and professional services.

#### *Subscriptions*

*SELECT subscriptions.* We provide prepaid annual recurring subscriptions that accounts can elect to add to a new or previously purchased perpetual license. SELECT provides accounts with benefits, including upgrades, comprehensive technical support, pooled licensing benefits, annual portfolio balancing exchange rights, learning benefits, certain Azure-based cloud collaboration services, mobility advantages, and access to other available benefits. Under Topic 606, SELECT subscription revenues are recognized as distinct performance obligations are satisfied. The performance obligations within the SELECT offering, outside of the portfolio balancing exchange right, are concurrently delivered and have the same pattern of recognition. These performance obligations are accounted for ratably over the term as a single performance obligation. Under Topic 605, SELECT subscriptions revenue was recognized on a ratable basis, over the subscription term.

*Enterprise subscriptions:* We provide Enterprise subscription offerings which provide our largest accounts with complete and unlimited global access to our comprehensive portfolio of solutions. ELS provides access for a prepaid annual fee. ELS contains a term license component, SELECT maintenance and support, and performance consulting days. The SELECT maintenance and support benefits under ELS do not include a portfolio balancing feature. Revenue is allocated to the various performance obligations based on their respective standalone selling prices. Revenue allocated to the term license component is recognized upon delivery at the start of the subscription term while revenues for the SELECT maintenance and support and the performance consulting days are recognized as delivered over the subscription term. Billings in advance are recorded as *Deferred revenues* in the consolidated balance sheets. Under Topic 605, ELS revenue was recognized on a ratable basis, over the subscription term.

E365 subscriptions, which were introduced during the fourth quarter of 2018, provide unrestricted access to our comprehensive software portfolio, similar to ELS, however are charged based upon daily usage. The daily usage fee includes a term license component, SELECT maintenance and support, and Success Plan services, which are designed to achieve business outcomes through more efficient and effective use of our software. E365 revenues are recognized based upon usage incurred by the account under both Topic 606 and 605. Usage is defined as distinct user access on a daily basis. The term of E365 subscriptions aligns with calendar quarters and revenue is recognized based on actual usage.

*Term license subscriptions:* We provide annual, quarterly, and monthly term licenses for our software products. Term license subscriptions contain a term license component and SELECT maintenance and support. Revenue is allocated to the various performance obligations based on their standalone selling price ("SSP"). ATL are generally prepaid annually for named user access to specific products. QTL subscriptions allow accounts to pay quarterly in arrears for license usage that is beyond their prepaid subscriptions. MTL subscriptions are identical to QTL subscriptions, except for the term of the license, and the manner in which they are monetized. MTL subscriptions require a CSS, which is described below. For ATL, revenue allocated to the term license component is recognized upon delivery at the start of the subscription term while revenue for the SELECT maintenance and support is recognized as delivered over the subscription term. Billings in advance are recorded as *Deferred revenues* in the consolidated balance sheets. Under Topic 605,

ATL revenues were recognized on a ratable basis, over the subscription term. For usage-based QTL and MTL subscriptions, revenues are recognized based upon usage incurred by the account under both Topics 606 and 605. Usage is defined as peak usage over the respective terms. The terms of QTL and MTL subscriptions align with calendar quarters and calendar months, respectively, and revenue is recognized based on actual usage.

Visas and Passports are quarterly or annual term licenses enabling users to access specific project or enterprise information and entitle certain functionality of our ProjectWise and AssetWise systems. Our standard offerings are usage based with monetization through our CSS program.

CSS is a program designed to streamline the procurement, administration, and payment process. The program requires an estimation of annual usage for CSS eligible offerings and a deposit of funds in advance. Actual consumption is monitored and invoiced against the deposit on a calendar quarter basis. CSS balances not utilized for eligible products or services may roll over to future periods or are refundable. Paid and unconsumed CSS balances are recorded in *Accruals and other current liabilities* in the consolidated balance sheets. Software and services consumed under CSS are recognized pursuant to the applicable revenue recognition guidance for the respective software or service and classified as subscriptions or services based on their respective nature.

#### *Perpetual licenses*

Perpetual licenses may be sold with or without attaching a SELECT subscription. Historically, attachment and retention of the SELECT subscription has been high given the benefits of the SELECT subscription. Perpetual license revenue is recognized upon delivery of the license to the user under Topic 606. Under Topic 605, the Company recognized perpetual licenses revenue ratably over a three-year term due to the portfolio balancing feature users obtain through their SELECT subscriptions.

#### *Services*

We provide professional services including training, implementation, configuration, customization, and strategic consulting services. We perform projects on both a time and materials and a fixed fee basis. Our recent and preferred contractual structures for delivering professional services include (i) delivery of the services in the form of subscription-like, packaged offerings which are annually recurring in nature, and (ii) delivery of our growing portfolio of Success Plans. Success Plans are standard offerings which offer a level of subscription service above the standard technical support offered to all accounts as part of their SELECT or Enterprise agreement. Revenues are recognized as services are performed under both Topic 606 and 605.

#### **Significant Judgments and Estimates:**

*Revenue recognition.* Our contracts with customers may include promises to transfer licenses (perpetual or term-based), maintenance, and services to a user. Judgment is required to determine if the promises are separate performance obligations, and if so, the allocation of the transaction price to each performance obligation. When an arrangement includes multiple performance obligations which are concurrently delivered and have the same pattern of transfer to the customer, we account for those performance obligations as a single performance obligation. For contracts with more than one performance obligation, the transaction price is allocated among the performance obligations in an amount that depicts the relative SSP of each obligation. Judgment is required to determine the SSP for each distinct performance obligation. In instances where SSP is not directly observable, such as when we do not sell the product or service separately, we determine the SSP using information that may include market conditions and other observable inputs. We use a range of amounts to estimate SSP when we sell each of the products and services separately and need to determine whether there is a discount that should be allocated based on the relative SSP of the various products and services.

Our SELECT agreement provides users with perpetual licenses a right to exchange software for other eligible perpetual licenses on an annual basis upon renewal. We refer to this option as portfolio balancing and concluded that the portfolio balancing feature represents a material right resulting in the deferral of the associated revenue. Judgment is required to estimate the percentage of users who may elect to portfolio

balance and considers inputs such as historical user elections. This feature is available once per term and must be exercised prior to the respective renewal term. We recognize the associated revenue upon election or when the portfolio balancing right expires. This right is included in the initial and subsequent renewal terms and we reestablish the revenue deferral for the material right upon the beginning of the renewal term. As of December 31, 2019, we had deferred \$18,060 related to portfolio balancing exchange rights which is included in *Deferred revenues* in the consolidated balance sheet. As of June 30, 2020, we have deferred \$17,522 related to portfolio balancing exchange rights which is included in *Deferred revenues* in the consolidated balance sheet.

*Business combinations.* We allocate the fair value of the consideration transferred to the assets acquired and liabilities assumed, including trademarks, customer relationships, in-process research and development, and acquired software and technology, based on their estimated fair values at the acquisition date. Any residual purchase price is recorded as goodwill. The purchase price allocation requires us to make significant estimates and assumptions, especially at the acquisition date, with respect to intangible assets and deferred revenue obligations.

Although we believe the assumptions and estimates we have made are reasonable, they are based in part on historical experience and information obtained from the management of the acquired companies and are inherently uncertain. Examples of critical estimates used in valuing certain of the intangible assets we have acquired or may acquire in the future include but are not limited to:

- future expected cash flows from sales, maintenance agreements, and acquired developed technologies;
- the acquired company's trade name and customer relationships as well as assumptions about the period of time the acquired trade name and customer relationships will continue to be used in our product portfolio;
- expected costs to develop the in-process research and development into commercially viable software and estimated cash flows from the projects when completed; and
- discount rates used to determine the present value of estimated future cash flows.

These estimates are inherently uncertain and unpredictable, and if different estimates were used the purchase price for the acquisition could be allocated to the acquired assets and liabilities differently from the allocation that we have made. In addition, unanticipated events and circumstances may occur, which may affect the accuracy or validity of such estimates, and, if such events occur, we may be required to record a charge against the value ascribed to an acquired asset or an increase in the amounts recorded for assumed liabilities.

*Goodwill and other intangible assets.* Intangible assets arise from acquisitions and principally consist of goodwill, trademarks, customer relationships, and acquired software and technology. Intangibles, other than goodwill, are amortized on a straight-line basis over their estimated useful lives, which range from three to ten years (see Note 6 to our consolidated financial statements included elsewhere in this prospectus).

Goodwill consists of the excess of cost over the fair value of net assets acquired in business combinations. Goodwill is not amortized. Instead, it is tested annually for impairment, or more frequently if events occur or circumstances change that would more likely than not reduce its fair value below its carrying amount. We operate as a single reporting unit.

The initial step in evaluating goodwill for impairment requires us to determine the reporting unit's fair value and compare it to the carrying value, including goodwill, of such reporting unit. As part of the assessment, an entity may first qualitatively assess whether it is more likely than not (a likelihood of more than 50 percent) that a goodwill impairment exists. In evaluating whether it is more likely than not that a goodwill impairment exists, we consider the factors identified in ASC 350, *Intangibles — Goodwill and Other*. We also consider whether there are significant differences between the carrying amount and the estimated fair value of its assets and liabilities, and the existence of significant unrecognized intangible assets. Based upon our most recent annual impairment assessment completed as of October 1, 2019, it is not more likely than not that a goodwill impairment exists. There was no impairment of goodwill as a result of our annual impairment assessments conducted during the years ended December 31, 2018 or 2019.



*Property and equipment.* Property and equipment are recorded at cost less accumulated depreciation. Depreciation is calculated using the straight-line method over the estimated useful lives of the assets, which range from three to twenty-five years. Leasehold improvements are depreciated over the shorter of the estimated useful life of the leasehold improvements or the lease term. Land is not depreciated. Depreciation for equipment commences once it is placed in service and depreciation for buildings and leasehold improvements commences once they are ready for their intended use.

Cost of maintenance and repairs is charged to expense as incurred. Upon retirement or other disposition, the cost of the asset and the related accumulated depreciation are removed from the accounts and any resulting gain or loss is reflected in the consolidated statements of operations.

*Leases.* We determine if an arrangement is a lease at inception. Operating leases are included in *Operating lease right-of-use assets*, *Operating lease liabilities*, and *Long-term operating lease liabilities* in our consolidated balance sheets. Operating lease right-of-use assets represent our right to use an underlying asset for the lease term and operating lease liabilities represent our obligation to make lease payments arising from the lease. Operating lease right-of-use assets and operating lease liabilities are recognized at the commencement date based on the present value of lease payments over the lease term. We use our incremental borrowing rate, if our leases do not provide an implicit rate, based on the information available at the commencement date in determining the present value of lease payments. The incremental borrowing rate is determined based on our estimated credit rating, the term of the lease, economic environment where the asset resides, and full collateralization. The operating lease right-of-use assets also include any lease payments made and are reduced by any lease incentives. Options to extend or terminate the lease are considered in determining the lease term when it is reasonably certain that the option will be exercised. Lease expense for lease payments is recognized on a straight-line basis over the lease term. Our operating leases are primarily for office space, cars, and office equipment. Finance leases are included in *Property and equipment, net*, *Accruals and other current liabilities*, and *Other liabilities* in our consolidated balance sheet.

*Allowance for doubtful accounts.* We establish an allowance for doubtful accounts for estimated losses expected during the accounts receivable collection process. The allowance for doubtful accounts is presented separately in the consolidated balance sheet and reduces the accounts receivable balance to the net realizable value of the outstanding accounts and installment receivables. The development of the allowance for doubtful accounts is based on an expected loss model that considers reasonable and supportable forecasts of future conditions and a review of past due amounts, historical write-off and recovery experience, as well as aging trends affecting specific accounts and general operational factors affecting all accounts. Account balances are charged off against the allowance after all means of collection have been exhausted and the potential for recovery is considered remote.

We consider current economic trends when evaluating the adequacy of the allowance for doubtful accounts. If circumstances relating to specific customers change or unanticipated changes occur in the general business environment, our estimate of the recoverability of receivables could be further adjusted.

*Derivatives not designated as hedging instruments.* On March 31, 2020, we entered into an interest rate swap with a notional amount of \$200,000 and a ten-year term to reduce the interest rate risk associated with our Credit Facility. The interest rate swap is not designated as a hedging instrument for accounting purposes. We account for the swap as either an asset or a liability on the consolidated balance sheet and carry the derivative at fair value. Gains and losses from the change in fair value are recognized in *Other income (expense), net* and payments related to the swap are recognized in *Interest expense, net* in the consolidated statements of operations. The bank counterparty to the derivative potentially exposes us to credit-related losses in the event of nonperformance. To mitigate that risk, we only contract with counterparties who meet our minimum requirements under our counterparty risk assessment process. We monitor counterparty risk on at least a quarterly basis and adjust our exposure as necessary. We do not enter into derivative instrument transactions for trading or speculative purposes.

*Income taxes.* We account for income taxes under the asset and liability method, which requires the recognition of deferred tax assets and liabilities for the expected future tax consequences of events that have been included in the consolidated financial statements. Under this method, deferred tax assets and liabilities are determined based on net operating loss carryforwards, credit carryforwards, and temporary differences between the financial statement and tax basis of assets and liabilities using enacted tax rates in effect for

the year in which the items are expected to reverse. The effect of a change in tax rates on deferred tax assets and liabilities is recognized in income in the period of the enactment date.

We record net deferred tax assets to the extent we believe the assets will more likely than not be realized. In making such determination, we consider all available positive and negative evidence, including scheduled reversals of deferred tax liabilities, projected future taxable income, tax planning strategies, and recent financial operations. In the event we determine that we will not be able to realize deferred income tax assets in the future in excess of our net recorded amount, an adjustment to the valuation allowance would be recorded that would increase the provision for income taxes.

On December 22, 2017, the U.S. Tax Cuts and Jobs Act was enacted. This act, among other things, reduces the U.S. federal income tax rate to 21% from 35% in 2018, institutes a dividends received deduction for foreign earnings with a related tax for the deemed repatriation of unremitted foreign earnings, and creates a new U.S. minimum tax on earnings of foreign subsidiaries. We completed our accounting for the effects of this legislation in 2018 and have included those effects in *Provision for income taxes* in the accompanying consolidated statements of operations.

We perform a quarterly assessment of the recoverability of the net deferred tax assets and believe that we will generate sufficient future taxable income in appropriate tax jurisdictions to realize the net deferred tax assets. Our judgment regarding future profitability may change due to future market conditions and other factors, including intercompany transfer pricing adjustments. Any change in future profitability may require material adjustments to these net deferred tax assets, resulting in a reduction in net income in the period when such determination is made. We believe our tax positions, including intercompany transfer pricing policies, are consistent with the tax laws in the jurisdictions in which we conduct our business. It is possible that these positions may be challenged by jurisdictional tax authorities and may have a significant impact on our effective tax rate.

We are subject to income taxes in the United States and in numerous foreign jurisdictions. As part of the process of preparing our consolidated financial statements, we are required to calculate our income tax expense based on taxable income by jurisdiction. There are many transactions and calculations about which the ultimate tax outcome is uncertain. As a result, our calculations involve estimates by management. Some of these uncertainties arise as a consequence of revenue-sharing, cost-reimbursement and transfer pricing arrangements among related entities, and the differing tax treatment of revenue and cost items across various jurisdictions. If we were compelled to revise or to account differently for our arrangements, that revision could affect our tax liability. While we believe the positions we have taken are appropriate, we record reserves for taxes to address potential exposures involving tax positions that we believe could be challenged by taxing authorities. We record a benefit on a tax position when we determine that it is more likely than not that the position is sustainable upon examination, including resolution of any related appeals or litigation processes, based on the technical merits of the position. For tax positions that are more likely than not to be sustained, we measure the tax position at the largest amount of benefit that has a greater than 50 percent likelihood of being realized when it is effectively settled. We review the tax reserves as circumstances warrant and adjust the reserves as events occur that affect our potential liability for additional taxes. We follow the applicable guidance on derecognition, classification, interest and penalties, accounting in interim periods, disclosure, and transition with respect to uncertain tax positions. We recognize interest and penalties related to income taxes within the *Provision for income taxes* line in the consolidated statements of operations. Accrued interest and penalties are included within the related tax liability line in the consolidated balance sheets.

*Stock-based compensation.* We record all stock-based compensation as an expense in the consolidated statements of operations measured at the grant date fair value of the award. The fair value of stock option awards is determined using the Black-Scholes option pricing model. For all other equity-based arrangements, the share-based compensation expense is based on the share price at the grant date (see Note 15 to our consolidated financial statements included elsewhere in this prospectus).

The determination of the fair value of stock-based payment awards using an option pricing model is affected by our stock price as well as assumptions regarding a number of subjective variables. These variables include our estimated stock price, volatility over the term of the awards, expected term, risk-free interest rates, and expected dividends. The expected stock price volatility for our common stock is estimated by taking

the average historic price volatility for industry peers based on daily price observations over a period equivalent to the expected term of the stock option grants. We intend to continue to consistently apply this process using the same or similar public companies until a sufficient amount of historical information regarding the volatility of our own common stock share price becomes available. The expected term is based on the simplified method, which represents the average period from vesting to the expiration of the award. The risk-free interest rate is based on the U.S. Treasury yield curve with a remaining term equal to the expected life assumed at grant date.

*Fair value of common stock.* We have historically been a privately held company with no active public market of our common stock. We are required to estimate the fair value of the common stock underlying our stock-based awards. The fair value of the common stock underlying our equity-based awards was determined by our board of directors, with input from management and contemporaneous third-party valuations. We believe that our board of directors has the relevant experience and expertise to determine the fair value of our common stock.

Prior to the offering, and given the absence of a public trading market for our common stock, and in accordance with the American Institute of Certified Public Accountants practice guide, *Valuation of Privately-Held-Company Equity Securities Issued as Compensation*, our board of directors exercised reasonable judgment and considered numerous objective and subjective factors to determine the best estimate of the fair value of our common stock, including:

- contemporaneous independent valuations performed by an unrelated third-party valuation specialist;
- the nature of our business and its history;
- our operating and financial performance and forecast;
- present value of estimated future cash flows;
- the likelihood of achieving a liquidity event, such as an initial public offering, listing, or sale of our Company, given prevailing market condition and the nature and history of our business;
- any adjustment necessary to recognize a lack of marketability for our common stock;
- the market performance of comparable publicly traded companies; and
- the U.S. and global capital market conditions.

In valuing our common stock, our board of directors determined the equity value of our business generally using the income approach and the market comparable approach valuation methods.

The income approach estimates value based on the expectation of future cash flows that a company will generate such as cash earnings, cost savings, tax deductions, and proceeds from disposition. These future cash flows are discounted to their present values using a discount rate derived from an analysis of the cost of capital of comparable publicly traded companies in our industry or similar lines of business as of each valuation date and is adjusted to reflect the risks inherent in our cash flows.

The market comparable approach estimates value based on a comparison of the Company to comparable public companies in a similar line of business. To determine our peer group of companies, we considered public enterprises with similar operations and selected those that are similar to our size, stage of life cycle, and financial leverage. From the comparable companies, a representative market value multiple is determined and applied to our results of operations to estimate the value of the Company.

Application of these approaches involves the use of estimates, judgments, and assumptions that are highly complex and subjective, such as those regarding our expected future cash flows, cost savings and expenses, discount rates, market multiples, the selection of comparable companies, and the probability of possible future events. Changes in any or all of these estimates and assumptions or the relationships between those assumptions impacts our valuations as of each valuation date.

The following table summarizes, by grant date, all options awards since January 1, 2018 under our stockholder-approved plan. The estimated fair value per share of common stock in the table below represents the determination by our board of directors of the fair value of our common stock as of the date of grant,

taking into consideration the various objective and subjective factors described above, including the conclusions, if applicable, of contemporaneous valuations of our common stock.

Grant Date	Number of Shares Underlying Options	Exercise Price	Fair Value per Share of Common Stock
March 2018	20,000	\$ 6.805	\$ 6.805
May 2018	5,096,000	6.805	6.805
September 2018	10,000	8.670	8.670
March 2019	4,816,000	7.240	7.240
May 2019	10,000	7.240	7.240
March 2020	10,000	10.840	10.840

#### Emerging Growth Company:

Section 107 of the JOBS Act provides that an “emerging growth company” can use the extended transition period provided in Section 7(a)(2)(B) of the Securities Act, as amended by Section 102(b)(1) of the JOBS Act, for complying with new or revised accounting standards. This permits an “emerging growth company” to delay the adoption of new or revised accounting standards that have different effective dates for public and private companies until those standards would otherwise apply to private companies. We have elected to use the extended transition period provided in Section 7(a)(2)(B) for complying with new or revised accounting standards that have different effective dates for public and private companies until the earlier of the date we (i) are no longer an “emerging growth company” or (ii) affirmatively and irrevocably opt out of the extended transition period provided in Section 7(a)(2)(B). As a result, our consolidated financial statements may not be comparable to those of companies that comply with public company effective dates.

#### Off-Balance Sheet Arrangements:

We do not have any off-balance sheet arrangements, as defined by applicable SEC regulations.

#### Recent Accounting Pronouncements:

For information regarding recent accounting guidance and the impact of this guidance on our consolidated financial statements, see Note 2 to our consolidated financial statements included elsewhere in this prospectus.

#### Quantitative and Qualitative Disclosures about Market Risk:

Market risk represents the risk of loss that may impact our financial position due to adverse changes in financial market prices and rates. Our market risk exposure is primarily a result of fluctuations in foreign currency rates, although we also have exposure due to potential changes in interest rates. We do not hold financial instruments for trading purposes.

*Foreign currency exchange risk.* Our revenue, earnings, cash flows, receivables, and payables are subject to fluctuations due to changes in foreign currency exchange rates. We regularly evaluate our foreign currency positions in the context of the natural hedging of revenues and expenses and corresponding exposure. We have concluded that our naturally hedged positions support our strategy and no incremental hedging strategies have been deployed. The primary currencies for which we have exchange rate exposure are the U.S. Dollar versus Euros, British Pounds, Australian Dollars, Canadian Dollars, and Chinese Yuan Renminbi. For the year ended December 31, 2019, approximately 58% of our revenues are derived from outside of the United States and approximately 47% of our revenues are denominated in foreign currencies. In 2019, 53%, 14%, 7%, and 26% of our revenues were denominated in U.S. Dollars, Euros, British Pounds, and other currencies, respectively, and 54%, 17%, 8%, and 21% of our expenses were denominated in U.S. Dollars, Euros, British Pounds, and other currencies, respectively. Financial results therefore are affected by changes in foreign currency rates. We estimate that a 10% strengthening of the U.S. Dollar versus our other currencies would have lowered our 2019 annual operating income by approximately \$10,200.

*Interest rate risk.* We had cash and cash equivalents of \$121,101 and \$125,516 as of December 31, 2019 and June 30, 2020, respectively, which consisted of bank deposits and money market funds maintained at various financial institutions. The cash and cash equivalents are held primarily for working capital purposes. Such interest-earning instruments carry a degree of interest rate risk. To date, fluctuations in interest income have not been significant. The primary objective of our investment activities is to preserve principal while maximizing income without significantly increasing risk. The interest rates on the Credit Facility also fluctuate based on various market conditions that affect LIBOR, the prime rate, or the overnight bank funding effective rate. The cost of borrowing thereunder may be impacted as a result of our interest rate risk exposure. Interest rate risk associated with the Credit Facility is managed through an interest rate swap which we executed on March 31, 2020. Under the terms of the swap, we fixed our LIBOR borrowing rate at 0.73% on a notional amount of \$200,000 and for a period of ten years. We do not enter into investments or derivative instruments for trading or speculative purposes. Due to the short-term nature of our investments, we have not been exposed to, nor do we anticipate being exposed to, material risks due to changes in interest rates. A hypothetical 10% change in interest rates during any of the periods presented would not have had a material impact on our consolidated financial statements.

*Inflation risk.* We do not believe that inflation has had a material effect on our business, financial condition, or results of operations.

## **FOUNDERS' PERSPECTIVES: LETTER FROM GREG, BARRY, KEITH, AND RAY BENTLEY**

Thank you for your interest in purchasing shares of Bentley Systems, which would make us fellow investors in advancing infrastructure through going digital. As the majority owners and majority of Board members, we realize that this is our opportunity to help you understand our corporate philosophy, so that you can consider whether it aligns with your investment preferences. In a nutshell, we hope that our approach tolerably coincides with how you would make decisions in managing your own family's company, but we want to best inform your investment choice by being direct and factual about our history and plans for the future.

### **Bentley Systems: 1984 – 2020**

Barry, Keith, and Ray are respectively chemical, electrical, and mechanical engineers who have spent their entire careers in software. Even Greg, prior to joining the rest of us, was a successful developer of software for what he characterizes as “financial engineering.” Having engineer types in charge seems to have worked for us, perhaps because of the correspondence to our end market of infrastructure engineering.

The four of us are not selling shares in this offering, nor do we contemplate any “exit” other than (as we are all aged in our early 60s) in due course following the example of Barry, who retired at the beginning of this year but remains active on our Board. We plan to continue our modest regular dividend, which will serve to encourage this orderly progression.

From entrepreneurial experience, we are strong believers in the motivating “secret sauce” of equity ownership. We realize that our own success in software correlates directly with our colleagues' quality, motivation, and retention. Genuinely shared commitment is contagious and powerful, leading ultimately to this public company destiny.

Over 1,200 of our colleagues (and by now, some are retirees) have earned over one-third of our company's ownership through our pervasive stock incentive programs. Facilitated by the NASDAQ Private Market since 2016, some have sold shares to our strategic alliance partner Siemens at pre-arranged share prices. This public listing fulfills our intention for our colleagues to be rewarded, for having devoted their prime working lives, with the deserved satisfaction of their equity being valued by the independent market, rather than by formula. To complete our goal of colleague ownership, we have preceded this IPO with grants of nearly one million shares distributed across every one of our approximately 4,000 colleagues.

### **BSY: 2020 – ...**

Because the “no drama” continuity assured by family stewardship has proven to be a significant competitive advantage from the standpoint of our accounts and our colleagues, BSY will be structured to remain protected from hostile acquirors and/or activist investors with short-term agendas. Rather than compromising our focus, when public we intend to steadfastly adhere to the consistent long-term decision horizon which has guided us as a private company. We will prioritize proactive investments when we believe substantial opportunities will sufficiently benefit our future, even if that might jeopardize short-term expectations. So while we will continue to hold ourselves accountable to become more efficient as we consistently grow, and while our cumulative subscription preponderance and operating discipline enable relatively strong near-term visibility, we will not concentrate on quarterly performance metrics.

Compounding short-term measurement issues, the noise from new revenue accounting rules creates, in our reported results, misleading volatility that doesn't exist in economic reality. Therefore, to avoid the risks of misinterpretation by analysts and markets, we intend to refrain from providing quarterly financial guidance. However, we will undertake to update our annual financial guidance when that is merited, in transparent accordance with the metrics that we find most useful internally.

In corporate governance, you can be assured of our alignment with shareholders at large, whom will always be well represented by independent directors of the highest quality. While continuing our established high standards of corporate citizenship, we believe all shareholders are best served by BSY's undiluted attention to serving our users, our accounts, and our colleagues. It is generally not our business to advocate for causes beyond the self-evident virtues we depend upon: free markets, free trade and globalization, and (private as well as public) infrastructure investment.

By virtue of long experience we can conclude that for a software company, it is an advantage for key decisions to be made by those whom are literally “in software.” Our unique and trusted technical continuity across successive software generations has established a key competitive differentiator in BSY’s favor, for long-lived infrastructure projects and endless-lived infrastructure assets.

Accordingly, we take most seriously our responsibility for similarly qualified succession in BSY’s executive leadership. We have suitable plans and prospects in mind, including having recently recruited successfully from top levels at leading public software companies. Our successors will have the continuity benefit of many years of anticipated overlap with our Board tenures, but we also have ambitions to improve upon our own leadership, and certainly in dimensions beyond engineering.

Indeed, spending almost all of our careers working with brothers (who are certainly not easily impressed with each other) has hopefully inclined us toward humility rather than hubris. While we are proud of our many next-generation Bentleys in various roles at the company, we have programmed against dynastic succession. In BSY’s dual-class share voting formulation, our voting multiple ratchets down when the director Bentleys leave the Board, and reverts to parity if and when we and our collective heirs might own less than 20% of BSY’s common shares.

### **BSY: The Infrastructure Engineering Software Company**

We feel strongly that BSY’s work since its founding has represented the highest and best use of our collective endeavors. And we have succeeded to date because of the contributions and commitment of our diverse colleagues globally. We have all been brought together and motivated by what we’ve enabled infrastructure engineers to accomplish everywhere.

Our world’s economy and environment rely on physical infrastructure, advanced by infrastructure engineering, which is empowered by infrastructure engineering software. Many global imperatives hinge on infrastructure engineers going digital — including climate mitigation and adaptation, industrialization of project delivery for better infrastructure economics, increased private investment attracted by greater project and asset visibility, and economic development being propagated globally. The pandemic challenges of 2020 underscore the prospective importance of digital twins in sustaining infrastructure’s resilience and fitness for purpose.

There could not be more direct and palpable benefits from software careers than the work of our users, of which we are so proud. In your consideration of a BSY investment, we hope you take some time to review the impressive case studies, nominated for awards for going digital, that have been compiled in our annual Infrastructure Yearbooks. Whatever you decide about investing with our family, we think you will gain a greater appreciation for infrastructure, infrastructure engineers, and our colleagues responsible for their software — to whom BSY’s public offering is literally dedicated.

/signed

Greg Bentley

Barry Bentley

Keith Bentley

Ray Bentley





## Going Digital: SPECIAL RECOGNITION AWARD WINNERS



### Advancing Construction Industrialization through Digital Twins

#### Digital Application in Heilongjiang Construction Industry Modernization Demonstration Park

Heilongjiang Construction High-Tech Capital Group Co., Ltd.  
*Harbin City, Heilongjiang, China*

Heilongjiang Construction High-Tech Capital Group was part of a 1.26-million-square-meter modernization demonstration park, which is aimed at transforming traditional construction into an environmentally, green economic industry. The CNY 3.6 billion project required multiple, dispersed participants to collaborate on a tight planning, design, and construction timeline.

With Bentley applications, the project team developed a digital twin and connected data environment that:

- shortened design time by five days and cost evaluation time by 80%;
- helped generate an accurate 3D reality model that improved earthworks measurements and calculations by two times;
- saved CNY 4.5 million in construction costs.

**Project Playbook:** *ContextCapture, LumenRT, MicroStation, Navigator, OpenBuildings Designer, OpenRoads, ProjectWise, ProStructures, STAAD*

### Advancing Digital Workflows through Digital Twins

#### High Speed Two Sectors N1 and N2 Main Works Civil Contract

Mott MacDonald/SYSTRA Designers working with Balfour Beatty/VINCI Joint Venture  
*Birmingham, Country North Sectors, United Kingdom*

Working on behalf of Balfour Beatty VINCI Joint Venture, Mott MacDonald and SYSTRA were tasked with developing the Stage 1 design scheme for a 70-kilometer stretch of High Speed Two Limited's railway route from London to Birmingham (HS2 Phase One). The stretch includes 320 primary assets and 550 sub-assets.

With Bentley applications, the project team used model-based delivery that:

- helped produce more than 4,000 models as the source of all information;
- reduced program time and cost while improving collaboration and engagement;
- achieved behavioral changes and skills development among project stakeholders.

**Project Playbook:** *OpenBuildings Designer, glNT, iModelHub, MicroStation, Navigator, OpenBridge, OpenRail, OpenRoads, Power Rail Track, ProjectWise, SYNCHRO*

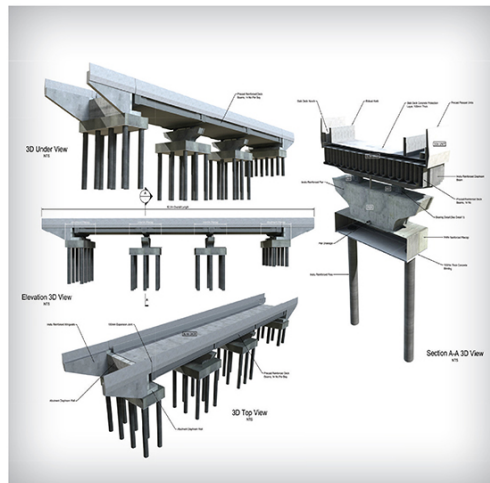



## Advancing Economic Infrastructure through Digital Twins

### SAPT Automatic Container Yard and Housing Project in Pakistan

CCCC Water Transportation Consultants (WTC) Co., Ltd.  
Karachi, Sindh, Pakistan

CCCC Water Transportation Consultants was tasked with constructing engineering assets for an estimated USD 90 million port that includes automated container yards, auxiliary buildings, railways, and other supporting facilities. The project needed to meet strict construction quality requirements and a tight timeframe while avoiding pipe network and civil foundation collisions.

With Bentley applications, the project team created and applied a BIM model that:

- combined all asset models into one location;
- improved collaboration by 35% and modeling efficiency by 30%;
- detected 300 collision points and reduced costs by 5%.

**Project Playbook:** LumenRT, MicroStation, Navigator, OpenBuildings Modeler, OpenRail, OpenRoads, ProjectWise, ProStructures, STAAD



## Advancing Industrial Sustainability through Digital Twins

### Henan Jiyuan Iron & Steel, 80MW High-Temperature Ultrahigh-Pressure Gas Power Generation Energy-Saving Renovation Project

MCC Capital Engineering & Research Incorporation Ltd.  
Jiyuan, Henan, China

MCC Engineering and Research was tasked with coordinating various engineering disciplines for a new, 80-megawatt, high temperature, ultra-high-pressure gas power generation unit. The owner-operator of an industrial waste gas recycling and reuse facility wanted the old pressure generator to be demolished as well.

With Bentley applications, the project team developed an integrated 3D model that:

- shortened design time to four months and improved design efficiency by five times;
- reduced the construction period by five months;
- lightened the load of North China's power grid while reducing environmental impact.

**Project Playbook:** AutoPIPE, Bentley Raceway and Cable Management, Bentley Substation, LumenRT, MicroStation, Navigator, OpenBuildings Designer, OpenPlant, ProjectWise, ProSteel, ProStructures, SYNCHRO

## Going Digital: SPECIAL RECOGNITION AWARD WINNERS

### Advancing Infrastructure Resilience through Digital Twins

#### The New Polcevera Viaduct

Italferr S.p.A.  
Genoa, Liguria, Italy

After a bridge collapse in northern Italy, Italferr S.p.A. was tasked with designing a new EUR 202 million viaduct that would be a pivotal transportation point. The project needed to measure over 1,000 meters in length and consist of 19 steel-concrete spans.

With Bentley applications, the project team implemented a BIM model and connected data environment that:

- created digital models of the terrain, road, civil works, and systems;
- reduced design costs and improved collaboration for faster decision-making, more accurate calculations, and better management of revisions;
- kept the project on schedule for a June 2020 completion.

**Project Playbook:** *Descartes, gINT, iModel.js, LumenRT, MicroStation, Navigator, OpenBuildings Designer, OpenRoads, ProjectWise, SYNCHRO*



### Advancing Urban Planning through Digital Twins

#### The Digital Design for the Establishment of the Kwu Tung North and Fanling North, New Development Area

Civil Engineering and Development Department,  
Hong Kong SAR Government and AECOM  
Hong Kong

AECOM Asia Co. was tasked with helping create new development areas to address long-term housing demands in Hong Kong. The project will cover 4.5 square kilometers and will accommodate 119,600 people, becoming one of the most densely populated areas in Hong Kong.

With ContextCapture, OpenBuildings Designer, and LumenRT, the project team used building information modeling to create 3D spatial models that:

- improved model analysis and communication with stakeholders;
- allowed for 10 significant and 50 minor design changes directly in the model.

**Project Playbook:** *ContextCapture, LumenRT, OpenBuildings Designer, ProjectWise*





## Digital Cities Award for Comprehensive Roadway Digital Twins

### Yangang East Interchange Project

Shenzhen Expressway Engineering Consultants Co., Ltd  
*Shenzhen, Guangdong, China*

Shenzhen Expressway Engineering Consultants was tasked with designing the convergence of four high-speed roadways of the Yangang network. The complex network runs 10.5 kilometers in length and includes 10 new ramps, 16 bridges, and eight tunnels and underpasses.

With Bentley applications, the project team created a digital twin that:

- analyzed several traffic relief and design schemes for an optimal design and construction plan;
- facilitated real-time collaboration and data access, identifying and proactively resolving over 60% of site problems to avoid construction delays;
- simulated virtual on-site construction to verify workflows and meet the 35-month construction schedule.

**Project Playbook:** *ContextCapture, gINT, iModelHub, LumenRT, MicroStation, Navigator, OpenBridge, OpenRoads, Pointools, ProjectWise, ProStructures, SYNCHRO*

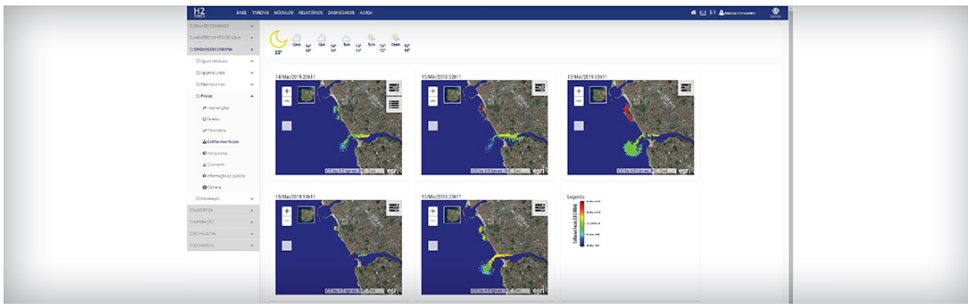

## Digital Cities Award for Comprehensive Water Digital Twins

### H2PORTO Technological Platform for the Integrated Management of Porto's Urban Water Cycle

Águas do Porto, EM  
*Porto, Portugal*

Águas do Porto delivers and collects an average of 50,000 cubic meters of water, serving almost 157,000 customers in Porto, Portugal's second largest city. Faced with integrating big data and models from numerous sources into an open, connected data environment, the organization needed integrated management of the urban water cycle.

With OpenFlows, the project team developed the H2PORTO technological platform that:

- incorporated over 22 different sources to create a digital twin of the city's water systems;
- facilitated seamless integration of information for proactive network maintenance and management;
- improved pipe burst repairs by 8% and decreased water supply interruptions and malfunctions by an estimated 20%.

**Project Playbook:** *OpenFlows, OpenFlows WaterGEMS*

## Going Digital: **AWARD WINNERS**



### Advancements in 4D Construction Modeling

#### Chase Center and Warriors Mixed-use Office and Retail Development

Mortenson | Clark, a Joint Venture  
*San Francisco, California, United States*

The Mortenson Clark joint venture was tasked with defining the schedule and workflow for the USD 1.2 billion Chase Center project, the new home of the Golden State Warriors and an entertainment complex for over 200 annual events. The project features two 11-story office buildings as part of five structures supported by a shared podium.

With SYNCRHO, the project team created a 4D construction model that:

- influenced schedule progression and assembly logic;
- created a model-driven, iterative simulation review for site logistics plans and critical path elements;
- evaluated construction sequencing and associated scopes of work for on-time delivery.

**Project Playbook:** SYNCRHO



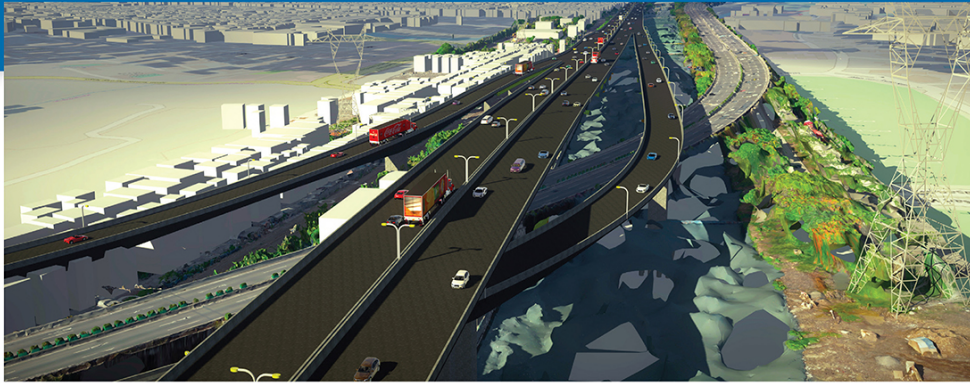

## Advancements in Bridges

### Design and Build Harbour Road 2 Project

PT. Wijaya Karya (Persero) Tbk.  
North Jakarta, Jakarta, Indonesia

PT. Wijaya Karya was tasked with avoiding aboveground and belowground structures of the USD 530 million Harbour Road 2 bridge, while working around two other projects occurring simultaneously. The 3.98-kilometer design and build project is the first elevated toll road project to use a double-decker construction.

With PLAXIS, OpenBridge Modeler, and OpenRoads, the project team:

- limited waste and decreased movement of heavy equipment, reducing carbon production;
- increased return on investment by 23%, cutting project time by three years;
- helped create a bridge that will accommodate 63,500 vehicles per day.

**Project Playbook:** *ContextCapture, gINT, LEAP, LumenRT, Navigator, OpenBridge, OpenRoads, PLAXIS, ProStructures, RM Bridge*

## Advancements in Buildings and Campuses

### Detailed Design, Tendering and Project Management Services for Establishment of 12 IT/Hi-Tech Parks in Bangladesh

Voyants Solutions Private Limited  
Bangladesh

Voyants Solutions was responsible for developing 12 high-tech IT parks in eight administrative regions of Bangladesh. The smart green campuses needed to be iconic and unique to facilitate economic and social growth while being completed in a short timeframe.

Using STAAD and OpenBuildings Designer, the project team:

- proposed a water lily design concept with optimized design coordination;
- submitted the schematic design 15 days early, saving 50% in design time, with 60% less resources, achieving an ROI of five times the initial investment;
- developed a 3D model that will further facilitate construction scheduling and monitoring.

**Project Playbook:** *LumenRT, OpenBuildings Designer, STAAD*



## Going Digital: AWARD WINNERS

### Advancements in Communications and Utilities

#### Technology Application in Miluo Western 220kV Substation Project

POWERCHINA Hubei Electric Engineering Co., Ltd.  
*Miluo City, Hunan, China*

POWERCHINA Hubei Electric Engineering assisted with the Miluo Western 220-kilovolt substation, the State Grid's first 3D pilot project employing 3D design standards during construction. Enhancing power reliability to 150,000 users, the CNY 113.2 million project needed to deliver a design within 10 months.

With ContextCapture, ProjectWise, and SYNCHRO, the project team provided a digital twin that:

- reduced design and review time by 65 days and land occupation by 0.94 hectares;
- reduced construction time by 30 days;
- saved CNY 1.5 million and delivered the project early.

**Project Playbook:** *Bentley Raceway and Cable Management, Bentley Substation, ContextCapture, LumenRT, MicroStation, Navigator, OpenBridge, OpenBuildings Designer, OpenPlant, ProjectWise, Promis.e, ProSteel, ProStructures, STAAD, SYNCHRO*



### Advancements in Digital Cities

#### Application of Digitalization in Jiujiang Smart Water Management Platform

Shanghai Investigation, Design & Research Institute Co., Ltd.  
Yangtze Ecology and Environment Co., Ltd.  
*Jiujiang, Jiangxi, China*

The Changjiang Ecological Environmental Protection Group and Shanghai Investigation, Design & Research Institute are building a CNY 7.7 billion smart water management pilot platform. The project includes a sewage plant, supporting network, and water ecological restoration.

With Bentley applications, the project team created a simulation and modeling platform that:

- produced a 3D reality model covering 220 square kilometers;
- reduced labor by 80%;
- cut down cost by 60%, saving about CNY 4 million.

**Project Playbook:** *ContextCapture, Descartes, iModelHub, LumenRT, Navigator, OpenBuildings Designer, OpenPlant, OpenRoads, ProjectWise*





## Advancements in Geotechnical Engineering

### Tanjong Pagar Mixed Development

Arup Singapore Pte. Ltd.  
Singapore

Arup Singapore was tasked with developing the Guoco Tower, a 64-story, mixed-use development project. With an 18-meter-deep, three-level basement connected to the existing underground Mass Rapid Transit (MRT) railway station, the project needed to meet specifications impacting the MRT and surrounding city structures.

With PLAXIS and gINT, the project team developed a digital foundation design that:

- reduced the number of iterative analysis procedures needed to predict long-term structure settlement;
- produced a geotechnical interpretive report within one week of completing the ground investigation works;
- facilitated a timely, cost-effective foundation and earth retaining structural scheme that simplified and accelerated construction.

**Project Playbook:** *gINT, MicroStation, PLAXIS*

## Advancements in Manufacturing

### Sulfuric Acid Plant Project in the DRC

Hatch  
Katanga, Democratic Republic of the Congo

Hatch was retained for a new, USD 245 million sulfuric acid manufacturing plant in the Democratic Republic of the Congo, including a 1,400 ton-per-day manufacturing facility and a 20-megawatt electrical waste heat system. The project needed to safely handle the high environmental risks of hauling acid to this remote area.

With STAAD, OpenPlant, and ProjectWise, the project team created a digital twin that:

- saved 10% to 15% in purchasing costs;
- streamlined digital workflows to cut six weeks from the delivery schedule;
- reduced production ramp-up time from six months to one week.

**Project Playbook:** *LumenRT, MicroStation, Navigator, OpenBuildings Designer, OpenPlant, ProjectWise, STAAD*





## Going Digital: AWARD WINNERS

### Advancements in Mining and Offshore Engineering

#### China Three Gorges New Energy Dalian Zhuanghe III (300MW) Offshore Wind Farm Project

Shanghai Investigation, Design & Research Institute Co., Ltd.  
*Dalian, Liaoning, China*

Shanghai Investigation, Design & Research Institute is working on a CNY 5.14 million offshore wind farm project with a total installed capacity of 300 megawatts. Set to be the first offshore wind power project in northwest China seas, the project needed multidiscipline communication and ice-resistance.

With Bentley applications, the project team developed a design and survey that:

- saved 230,000 tons of standard coal annually;
- reduced the emission of sulfur dioxide by 6,000 tons per year and carbon dioxide by 637,000 tons per year;
- provided seamless storage and access of data information for all participants.

**Project Playbook:** *MicroStation, Navigator, OpenBuildings Designer, OpenPlant, ProjectWise, ProSteel, SACS*

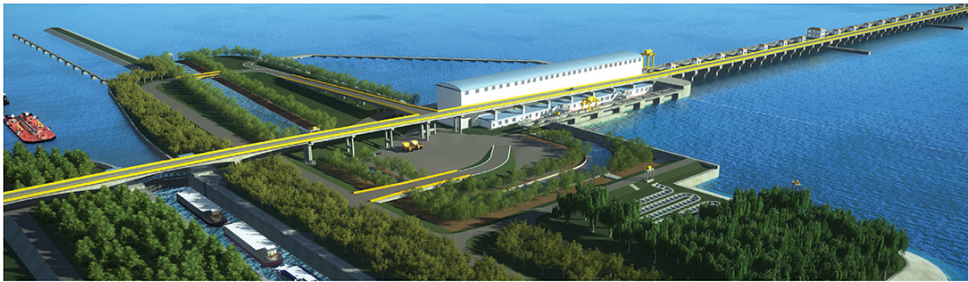

### Advancements in Power Generation

#### Hanjiang Yakou Shipping Hub Engineering Project

Hunan Hydro & Power Design Institute  
*Yicheng City, Hubei, China*

Hunan Hydro & Power Design Institute was tasked with developing the 75-megawatt capacity, CNY 3.35 billion Hanjiang Yakou Shipping Hub project. Alleviating an electricity shortage and achieving an annual navigation grade benefit of CNY 287 million, the project needed to accommodate the compact equipment space and 49-month construction period.

With ProjectWise and OpenBuildings Designer, the project team created a 3D information model that:

- improved design efficiency by 30% and accuracy by 17%;
- completed design work within 45 days and reduced on-site change orders by 80%;
- optimized workflow processes to realize electricity generation three months ahead of schedule.

**Project Playbook:** *Bentley Raceway and Cable Management, LumenRT, MicroStation, Navigator, OpenBuildings Designer, OpenPlant, OpenRoads, ProjectWise, ProStructures*

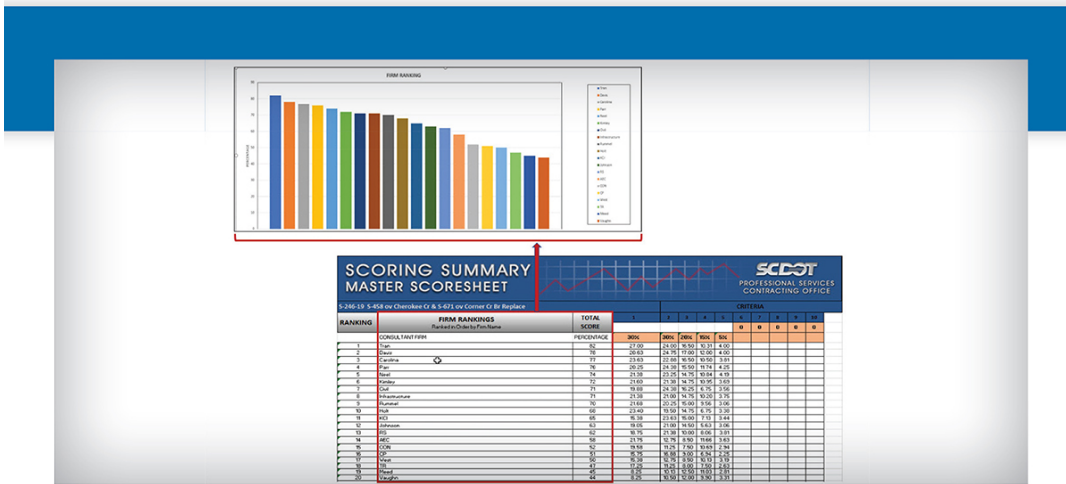

### Advancements in Project Delivery

#### Seamless Information Sharing and Integration Across Multiple Platforms Using ProjectWise

South Carolina Department of Transportation  
 Columbia, South Carolina, United States

The South Carolina Department of Transportation (SCDOT) currently manages 6,341 projects and 1,823 contracts through all phases of the project lifecycle. The organization needed to integrate disparate data and document applications so that it could support and manage common business processes, data, and document sharing across systems.

With ProjectWise, the project team created a digital twin of all sources of information that:

- achieved workflow efficiencies, increased productivity, and improved accuracy;
- streamlined consultant selection and scoring, enabling more contracts to be processed;
- saved time searching for information stored in multiple applications and reduced costs associated with maintaining multiple applications.

**Project Playbook:** ProjectWise

### Advancements in Rail and Transit

#### AV/AC in Southern Italy: Napoli-Bari Route

Italferr S.p.A.  
 Napoli-Bari, Campania-Puglia, Italy

Italferr was tasked with designing the EUR 6.2 billion Napoli-Bari route, which will integrate rail infrastructure in southeast Italy, shortening travel time by several hours. This project covers a 60-kilometer stretch from Apice to Bovino, where five mixed steel-concrete viaducts manage the transitions between tunnels and open-air construction.

With ProjectWise and OpenBuildings Designer, the project team implemented a BIM methodology that:

- facilitated data and information exchange among various parties;
- optimized and automated manual processes with parametric modeling;
- modeled technical project components to explore alternative scenarios, improve design quality and accuracy, and reduce costs.

**Project Playbook:** ContextCapture, Descartes, glNT, iModel.js, LumenRT, MicroStation, Navigator, OpenBuildings Designer, OpenRail Designer, OpenRoads, ProjectWise, SYNCHRO

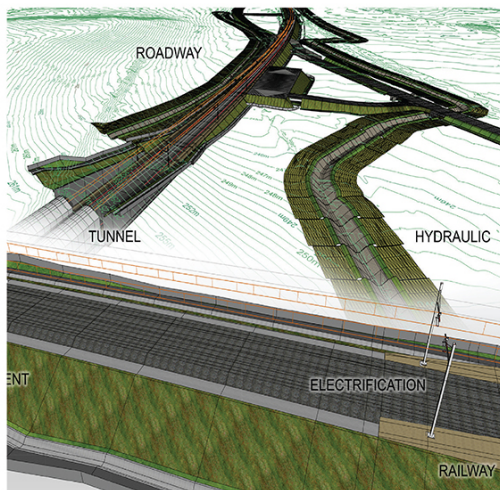

BENTLEY SYSTEMS

## Going Digital: AWARD WINNERS

### Advancements in Reality Modeling

#### Drone Surveying for BIM and GIS Data Capture – Malaysian Metro Megaproject

MMC Gamuda KVMRT (T) Sdn. Bhd.  
*Kuala Lumpur, Malaysia*

MMC Gamuda KVMRT was tasked with optimizing project design and constructability for the USD 7.5 billion Sungai-Buloh-Serdang-Putrajaya (SSP) Line, which serves approximately 2 million people. As Malaysia's first metro megaproject, it includes constructing 13.5-kilometer twin bored tunnels and 17 individual construction sites.

With ContextCapture and ProjectWise, the project team developed digital workflows that:

- delivered accurate 3D reality meshes of the site with high-quality images and infinite amounts of data;
- provided the interoperability to enhance understanding of existing site conditions;
- saved 1,000 resource hours for surveyors, engineers, and project managers.

**Project Playbook:** *AssetWise, ComplyPro, ContextCapture, Navigator, OpenRail, ProjectWise*



Ampang Park

### Advancements in Road and Rail Asset Performance

#### Pan Borneo Highway

Lebuhraya Borneo Utara Sdn. Bhd.  
*Sarawak, Malaysia*

Lebuhraya Borneo Utara was responsible for managing 32.77 kilometers of Malaysia's Pan Borneo Highway, a 1,060-kilometer, four-lane dual carriageway running through a complex location. The project serves as a benchmark for creating a complete asset management system for highways.

Using ProjectWise and AssetWise, the project team developed a connected data environment that:

- facilitated seamless integration of construction data for asset performance and reliability strategies;
- provided real-time reliable information for operations, maintenance, and engineering;
- mitigated risk, increased operational efficiency, improved decision-making, and ensured regulatory compliance.

**Project Playbook:** *AssetWise, ProjectWise*



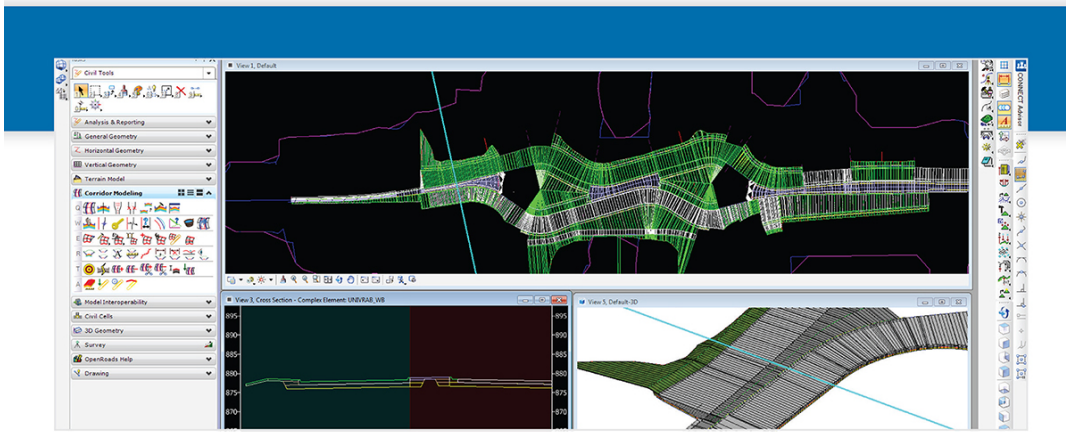

## Advancements in Roads and Highways

### Foth Transforms, Connects, & Revitalizes Cedar Falls, Iowa Corridor

Foth Infrastructure & Environment, LLC  
Cedar Falls, Iowa, United States

Foth was tasked with improving roadway and traffic conditions and providing non-vehicular access along University Avenue, a 60-year-old roadway serving over 20,000 vehicles per day. The USD 38.9 million revitalization required overcoming various challenges, compounded by aggressive schedules and intense public involvement.

Using Bentley applications, the project team developed a digital design model that:

- simplified storing, managing, and sharing over 130 gigabytes of data;
- identified and remediated design issues in hours rather than weeks;
- reduced the design phase by 50% with construction beginning a year and a half ahead of schedule.

**Project Playbook:** *Descartes, gINT, Haestad, iModel.js, LEAP, LumenRT, MicroStation, OpenFlow SewerGEMS, OpenFlow WaterGEMS, OpenRoads, ProjectWise, RAM, STAAD*

## Advancements in Structural Engineering

### WSP Delivers Optimized Design for Complex Basement Under Iconic Admiralty Arch

WSP  
London, United Kingdom

WSP was tasked with providing structural engineering for two new basements on either side of the Admiralty Arch as part of the new 96-room Waldorf Astoria hotel. The GBP 20 million basements are below an existing road and above two London Underground tunnels.

With PLAXIS and RAM, the project team completed a structural design that:

- included models for each construction stage for a reliable structural solution;
- addressed the challenge of acoustically isolating the basements by designing a box-in-box system;
- saved 25% of the structural design time, allowing WSP to complete the design phase one month ahead of schedule.

**Project Playbook:** *PLAXIS, RAM*

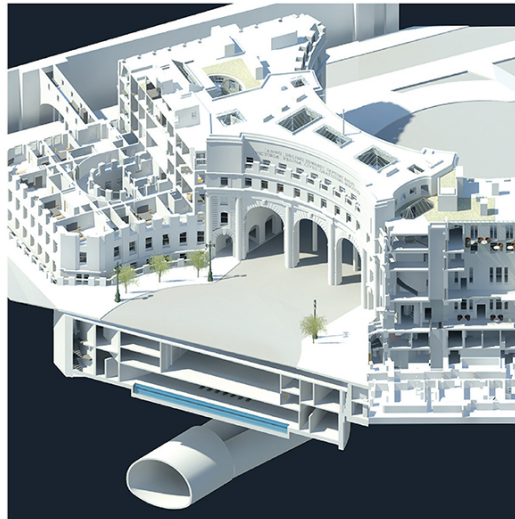

BENTLEY SYSTEMS

## Going Digital: AWARD WINNERS

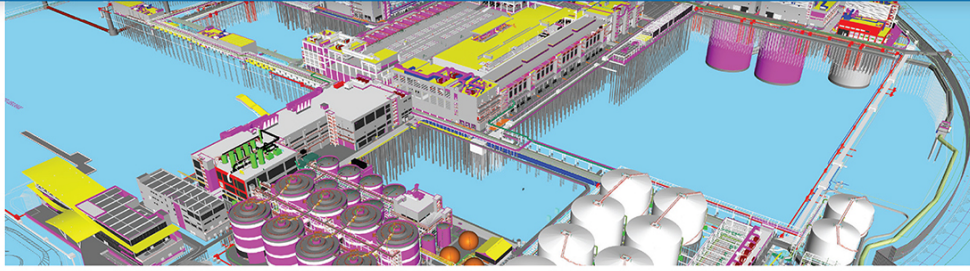

### Advancements in Water and Wastewater Treatment Plants

#### Tuas Water Reclamation Plant

Jacobs Engineering Group and Singapore's National Water Agency, PUB  
*Singapore*

Jacobs Engineering and Singapore's National Water Agency, PUB are part of the SGD 6.5 billion Deep Tunnel Sewerage System Phase 2 project, which will help serve Singapore's long-term used-water needs. The project needed to ensure design consistency, improve multidiscipline coordination, and model-based tendering and asset management.

With Bentley applications, the project team created fully federated 3D information models that:

- created a single source of truth among a globally dispersed team;
- ensured design consistency and multidiscipline coordination to save time;
- enabled instant access to the plant's data during construction and client handover.

**Project Playbook:** *LumenRT, MicroStation, Navigator, OpenBuildings Designer, OpenPlant, OpenPlant PID, OpenRoads, ProjectWise, STAAD*

### Advancements in Water, Wastewater and Stormwater Networks

#### Thames Tideway Tunnel

Balfour Beatty, Morgan Sindall, BAM Nuttall Joint Venture  
*London, United Kingdom*

The Balfour Beatty, Morgan Sindall, BAM Nuttall Joint Venture was tasked with delivering the GBP 450 million Thames Tideway Tunnel project, including a 25-kilometer-long tunnel under the River Thames. The joint venture needed to provide real-time data access and information sharing to accommodate the challenges among numerous project participants.

With ProjectWise, LumenRT, and SYNCHRO, the project team developed a digital twin that:

- facilitated construction management and stakeholder buy-in
- provided a simple user-friendly interface to save GBP 56,000 over a six-month period
- identified clashes in a virtual reality environment, optimizing construction and saving thousands in costs.

**Project Playbook:** *LumenRT, MicroStation, Navigator, OpenBuildings Designer, OpenRoads, ProjectWise, Promis.e, SYNCHRO*





**WINNER'S QUOTE**

Bentley provides industry-leading capabilities for network management and asset inventory coupled with unparalleled capabilities in the field of road asset maintenance.

AssetWise has helped us to optimize operations and maintenance through more informed decisions within a connected data environment to unlock economic and social benefits for the community along the Pan Borneo Highway Sarawak corridor.

*Sauani Abdul Hamid, Chief Executive Officer,  
Lebuhraya Borneo Utara Sdn. Bhd.*



The team of students from the Drummond Community High School in Edinburgh, Scotland, receive their award for their winning design in the "DEC Hyperloop Challenge."

## BUSINESS

### Our Mission

Bentley Systems' mission is to provide innovative software to advance the design, construction, and operations of the world's infrastructure — sustaining both the global economy and environment, for improved quality of life.

### Bentley Systems: The Infrastructure Engineering Software Company

We are a leading global provider of software for infrastructure engineering, enabling the work of civil, structural, geotechnical, and plant engineering practitioners, their project delivery enterprises, and owner-operators of infrastructure assets. We were founded in 1984 by the Bentley brothers. Our enduring commitment is to develop and support the most comprehensive portfolio of integrated software offerings across professional disciplines, project and asset lifecycles, infrastructure sectors, and geographies. Our software enables digital workflows across engineering disciplines, distributed project teams, from offices to the field, and across computing form factors, including desktops, on-premises servers, cloud-native services, mobile devices, and web browsers. We deliver our solutions via on-premise, cloud, and hybrid environments. Our users engineer, construct, and operate projects and assets across the following infrastructure sectors:

- *public works* (including roads, rail, airports, ports, and water and wastewater networks) / *utilities* (including electric, gas, water, and communications). We estimate that this sector represents 52% of the net infrastructure asset value of the global top 500 infrastructure owners (the “global top 500 infrastructure owners”) based on the 2019 edition of the *Bentley Infrastructure 500 Top Owners*, our annual compilation of the world's largest infrastructure owners ranked by net depreciated value of their tangible fixed assets;
- *industrial* (including discrete and process manufacturing, power generation, and water treatment plants) / *resources* (including oil and gas, mining, and offshore). We estimate that this sector represents 38% of the global top 500 infrastructure owners' net infrastructure asset value; and
- *commercial/facilities* (including office buildings, hospitals, and campuses). We estimate that this sector represents 10% of the global top 500 infrastructure owners' net infrastructure asset value.

Shown below (in the outer ring of the pie chart) are the proportions of our overall 2019 revenues attributable to these infrastructure sectors (and the indicated subsectors), either related to our products whose purpose is specific to a sector/subsector, or otherwise to use of our other products by accounts which we assign within the sector/subsector. The inner portion of the piechart shows the proportions of our overall 2019 revenues which are not accordingly attributable to any particular sector/subsector, being related to products used across multiple sectors/subsectors by accounts not assignable to a particular sector/subsector. These non-sector/subsector-specific revenues are categorized as either for products within specific infrastructure disciplines (structural or geotechnical), or otherwise within the product groupings of general modeling (including, for example, surveying) or general project delivery (including, for example, for general construction and general asset performance by general project delivery firms).

## 2019 Revenues by Discipline and Sector

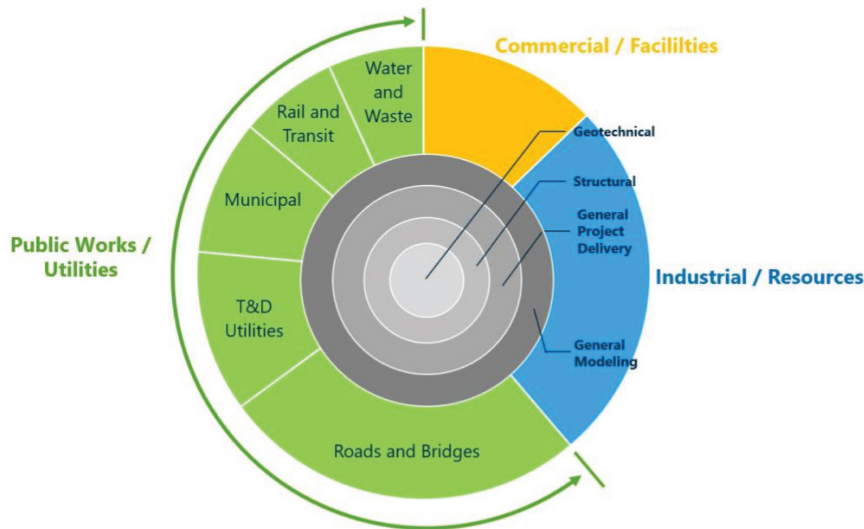

\* On an ASC 606 basis.

Infrastructure assets are among the world's largest and longest-lived investments, vital to both economic prosperity and environmental health. The quality of a region's infrastructure directly affects the region's capacity to meet constituents' essential needs for water, sanitation, energy, transport, and productive industries. Moreover, infrastructure considerations can affect the rate of global climate change and communities' vulnerability and resilience to negative climate change outcomes.

Infrastructure is complex due both to its physical scale and to its need for information connectedness at and between every stage of its lifecycle. Infrastructure design requires the structured collaboration of many engineering disciplines, often requiring globally dispersed teams. Infrastructure construction requires a distributed supply chain to reach an often remote location to realize a unique design. Infrastructure operations are mission critical, and require maintaining performance throughput and fitness-for-purpose for multiple generations. The design, construction, and operations of infrastructure require comprehensive solutions that can support and integrate rigorous workflows across professional disciplines in concert over the infrastructure lifecycle.

Our business, comprised of more than 4,000 colleagues, includes a "success force" of more than 900 colleagues with experience and credentials in infrastructure engineering. Our success force, coupled with 36 years of singular focus, has enabled us to create what we believe to be the most comprehensive infrastructure engineering software portfolio available today. Our comprehensiveness creates a formidable competitive advantage by providing our users integrated solutions for infrastructure projects and assets of nearly any type, scale, and complexity.

We address both the project and asset lifecycle phases of infrastructure, each with applications and enterprise information systems. Our Project Lifecycle solutions encompass conception, planning, surveying, design, engineering, simulation, and construction, as well as the collaboration offerings required to coordinate and share the work of interdisciplinary and/or distributed project teams. Our Asset Lifecycle solutions span the operating life of commissioned infrastructure assets, allowing our accounts to manage engineering changes for safety and compliance and to model performance and reliability to support operating and maintenance decisions.

Our revenues are balanced and diversified between engineering and construction contracting firms who work together to deliver the design and construction of capital projects (representing 55% of our 2019 revenues), and their clients, public and private infrastructure asset owners and operators (representing 45%



of our 2019 revenues). While engineering and construction contracting firms typically use our Project Lifecycle solutions, owner-operators are often involved in engineering and management for many of their own projects, and so can be users of our Project Lifecycle as well as our Asset Lifecycle solutions.

Our company’s “Advancing Infrastructure” tagline reflects our enduring track record in successfully leveraging new technologies to improve and integrate the design, construction, and operations of infrastructure, leading to our infrastructure digital twin. An infrastructure digital twin is a cloud-native 4D digital representation of a physical project and resulting asset, incorporating its underlying engineering information, that is applied to model, simulate, analyze, chronicle, and predict its performance over time. By adding digital twin services to our existing solutions, our users can more fully extend digital workflows across project delivery and asset performance, increasing the value of infrastructure engineers’ work.

We are the only infrastructure engineering software vendor to lead in market share in categories related to both the project and the asset lifecycle phases in the most recent rankings by The ARC Advisory Group (“ARC”). In August 2019, for *Engineering Design Tools for Plants, Infrastructure, and BIM* (building information modeling), ARC ranked us #2 overall, as well as #1 in each of Electric Transmission & Distribution and Communications and Water/Wastewater Distribution. In August 2019, ARC ranked us #1 in its inaugural market share study for Collaborative BIM. In December 2019, for *Asset Reliability Software & Services*, ARC ranked us #1 overall for software, as well as #1 in each of Transportation, Oil and Gas, and Electric Power Transmission and Distribution.

During the last two years, Microsoft recognized us as its 2019 “CityNext Partner of the Year” (citing our Azure-hosted *ProjectWise* for the Mumbai Trans Harbour Sea Link in India), its 2018 “CityNext Partner of the Year” (citing our Azure-hosted *ProjectWise* and *AssetWise* for the Klang Valley MRT in Kuala Lumpur, Malaysia), and a Finalist for the 2019 “Mixed Reality Partner of the Year Award” (citing our SYNCHRO XR 4D construction modeling application for the new HoloLens 2 device). Also, according to Microsoft, in 2019 we were one of the top 25 companies in terms of Azure usage globally.

We have spent decades cultivating trusted relationships with the largest global infrastructure engineering organizations. Our accounts include 90% of the top 250 of the *ENR 2019 Top 500 Design Firms*, which firms are ranked by revenue for design services performed in 2018, and 64% of the 2019 *Bentley Infrastructure 500 Top Owners*, which firms are ranked by net depreciated value of their tangible fixed assets. The *ENR 2019 Top 500 Design Firms* is authored by ENR and the *Bentley Infrastructure 500 Top Owners* is authored by us. These rankings consist of substantially distinct account lists (with the exception of a *de minimis* number of overlapping accounts), and such accounts collectively represented 42% of our total revenues for the year ended December 31, 2019. Our solutions are, in general, mission critical both for our accounts and for our professional users and foster a high degree of loyalty, with 80% of our 2018 and 2019 total revenues coming from accounts of more than ten years’ standing, and 87% of our 2018 and 2019 total revenues coming from accounts of more than five years’ standing.

Revenues by Account Type and Size

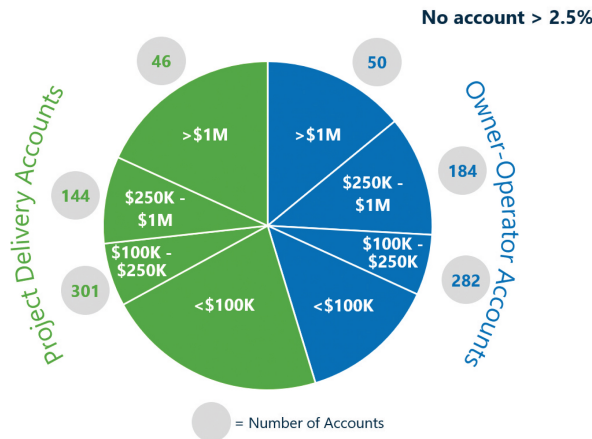

\* All figures as of December 31, 2019. All figures calculated using ASC 606. Chart segment sizing corresponds to underlying % of 2019 revenue.

We are a significant software vendor to major infrastructure engineering organizations. In 2018 and 2019, 88 and 96 accounts, respectively, each contributed over \$1 million to our revenues, representing 31% and 32% of our revenues, respectively. 50% of our 2018 revenues and 53% of our 2019 revenues came from 376 accounts and 424 accounts, respectively, each contributing over \$250,000 to our revenues. During 2018 and 2019, we served 36,718 and 34,127 accounts, respectively, and for the six months ended June 30, 2019 and 2020, we served 31,130 and 31,745 accounts, respectively. We determine “accounts” based on distinct contractual and billing relationships with us. Affiliated entities of a single parent company may each have an independent account with us. We have historically offered, and have in recent years enhanced, volume discount programs to incentivize such affiliated entities to consolidate their contractual relationships with us, resulting in a reduction to the number of distinct accounts so defined. No single account or group of affiliated accounts provided more than 2.5% of our 2018 or 2019 revenues.

Our business is comprehensively global. In 2019, the majority of our revenues were generated across 171 countries outside the United States, with 32.1% from EMEA and 19.5% from APAC. We have purposefully invested and are fully established in developing international markets where rapid infrastructure growth will continue to present compelling opportunities for us to scale efficiently. In particular, Greater China, which we define as the Peoples’ Republic of China, Hong Kong and Taiwan, and where we now have over 200 colleagues, has become one of our largest (among our top five) and fastest growing regions as measured by revenue, contributing just over 5% of our 2019 revenues.

In 2019, we generated subscription revenues of \$608 million, total revenues of \$737 million, net income of \$103 million and Adjusted EBITDA of \$188 million, and for the six months ended June 30, 2020, we generated subscription revenues of \$328 million, total revenues of \$379 million, net income of \$69 million and Adjusted EBITDA of \$116 million. Our business is cash-efficient, with approximately 70% of our revenues billed in advance, and a global tax rate of under 20%. For additional information on our financial result, key metrics, and non-GAAP financial metrics, see the section titled “Management’s Discussion and Analysis of Financial Condition and Results of Operations — Key Business Metrics.”

### Our Solutions

We offer solutions for enterprises and professionals across the infrastructure lifecycle. Our Project Delivery and Asset and Network Performance solutions are systems provided via cloud and hybrid environments, developed respectively to extend enterprise collaboration during project delivery, and to manage and leverage engineering information during operations and maintenance. Our Design Integration and Digital Cities solutions are primarily desktop applications and cloud-provisioned solutions for professional practitioners and workgroups. Our cloud-native Digital Twins solutions introduce digital workflows, which can span our Project Lifecycle and Asset Lifecycle solutions.

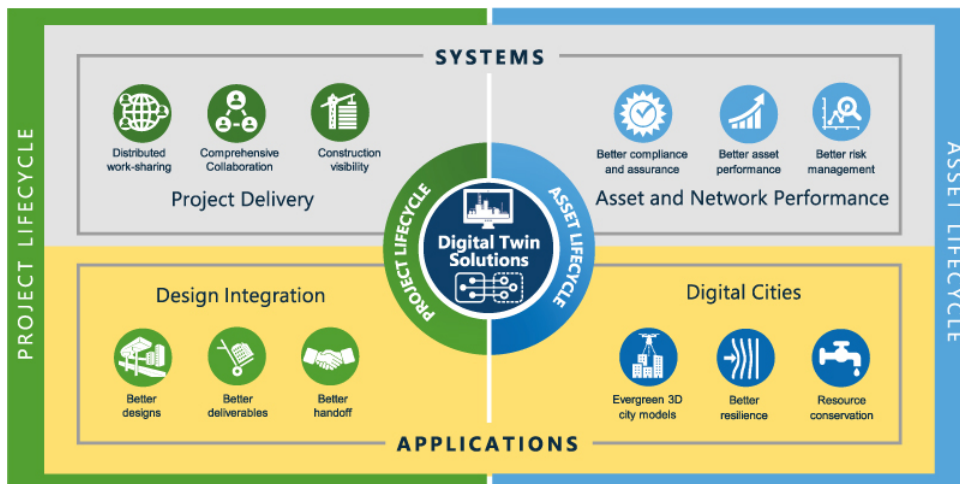

**Project Lifecycle Solutions.** Our Project Lifecycle solutions span conception, planning, surveying, design, simulation, and construction, as well as the collaboration software services required to coordinate and share the work of interdisciplinary and/or distributed project teams.

**Design Integration.** Our Design Integration solutions consist of modeling and simulation applications. Our modeling applications are domain-specific authoring tools used by professionals for the 3D design and documentation of infrastructure assets. Our simulation applications enable engineers to analyze the functional performance of the designs created with our modeling applications (or those of competitive vendors), preferably in iterative digital workflows, to improve engineering outcomes and to ensure compliance with design codes.

Benefits of our Design Integration applications to infrastructure engineers include:

- **Better designs.** Our modeling and simulation applications work together to improve infrastructure engineering quality, for instance to eliminate “clashes” across respective disciplines’ work. Each application is for a specific purpose (asset-type or discipline; for example, OpenRoads for roadway design), and supports corresponding asset-specific engineering workflows (for example, the workflow a civil engineer would use in designing a road) by virtue of:
  - **Better engineering productivity.** We endeavor to provide in our applications the most advanced and automated intelligence for transforming engineers’ conceptual decisions into complete, detailed, and editable deliverables; and
  - **Better configurability and continuity:** We take care to enable users to continuously refine their modeling preferences and standards across successive generations of our applications. This capability enables engineers, throughout their careers, to maintain continuity and compatibility with their preferred interfaces, formats, and methodologies, while advancing their work at the leading edge of innovation;
- **Better deliverables.** Our applications share a common modeling environment to enable streamlined coordination and production of multi-discipline documentation; and
- **Better handoff.** Our comprehensive modeling environment and our supplemental cloud services enable projects to enrich information sharing (and to minimize problematic translations) across project delivery processes. For instance:
  - by starting with reality modeling of existing conditions (often from drone surveying);
  - by sharing engineering component definitions across disciplines and projects; and
  - through “constructioneering” digital workflows, which automate the exchange of 3D design models to control GPS-enabled construction equipment (for earthmoving and paving), and to validate and preserve the resulting 3D as-built models for maintenance.

**Project Delivery.** Our Project Delivery solutions support information and document management, engineering-specific collaboration and work-sharing for distributed project teams and enterprises, and construction planning, modeling and execution. The scope of these solutions is not limited to users of only our own design applications.

Often during the project delivery lifecycle, key data are constantly changing, with inputs received from multiple sources, resulting in the need for a single source of information that is used to collect, manage, and disseminate information for the whole project team. Our software assures that the rapidly-changing data are managed in a common data environment (“CDE”) such that only the correct milestone versions can be shared and referenced across the project. This functionality enables infrastructure project organizations to “virtualize” their talent so that the required work can be shared by all participants everywhere through our software, reducing the need for physical co-location of the project resources.

Our 4D construction modeling software spatially and temporally integrates a project’s 3D engineering models into its construction schedules to assess sequencing strategies and to visualize and understand planned and actual progress over the project timeline. Our solutions also enable project delivery teams to optimally define and manage discrete engineering, construction, and installation work packages, including the construction trades’ “workface planning,” which considers crafts and materials by day and zone. For work

packages which increasingly take advantage of modular offsite fabrication and manufacturing, our software manages and enables 4D visualization of the necessary spatial and logistical interfaces.

Benefits of our Project Delivery solutions to project delivery enterprises include:

- *Distributed work-sharing:* Our solutions incorporate the rigorous workflow protocols required for structured coordination across engineering and construction supply chains, enabling global sourcing for integrated project delivery, while maximizing economics, quality, and safety;
- *Comprehensive collaboration:* Our software leverages cloud and hybrid environments to streamline the aggregation, distribution, and interaction for project deliverables, ensuring that the right project participants have the right information in the right format at the right time, including at the project site and on every device; and
- *Construction visibility:* Our solutions' broad span and continuous detail across design integration, construction modeling and work packaging, and mixed-reality 4D visualization, advances predictability, accountability, and safety throughout the construction process.

**Asset Lifecycle Solutions.** Our Asset Lifecycle solutions span the operating life of commissioned infrastructure assets, capturing and managing changes to engineering models and enterprise information for compliance and safety, and to model performance and reliability to support operating and maintenance decisions.

**Asset and Network Performance.** Our Asset and Network Performance solutions are used to manage engineering information and geospatial relationships for operating and provisioning infrastructure across all sectors, including linear networks for transportation and energy transmission and distribution. Our asset performance modeling provides the needed analytical context for "right-time" data, including from Internet of Things ("IoT") sensor capabilities, to yield actionable insights.

Benefits of our Asset and Network Performance Solutions for owner-operators include:

- *Better compliance and assurance:* Our systems intrinsically enforce the rigor appropriate for operating infrastructure assets in order to provide dependable visibility into the impact of changes;
- *Better asset performance:* Our solutions include operational dashboards that provide decision support insights to maintain and improve throughput and reliability; and
- *Better risk management:* Our solutions include predictive analytics that identify potential problems before they occur, and ensure the accessibility of best-available engineering information and models for mitigation and resilience.

**Digital Cities.** Our Digital Cities solutions incorporate reality modeling (leveraging drone and mobile mapping "survey" inputs) and geospatial context to continuously capture as-operated infrastructure conditions at city and regional scale. Our offerings support department-level applications for municipal engineering, such as simulation of pedestrian and vehicle traffic, and water and drainage systems.

Benefits of our Digital Cities solutions to cities, regions, and their constituents include:

- *Evergreen 3D city models:* Our reality modeling software maintains engineering-ready 3D models, incorporating incrementally updated surveys, and thus ensures that engineering departments can rely on up-to-date geospatial context for digital workflows;
- *Better resilience:* Our solutions can integrate geotechnical, structural/seismic, and hydrological engineering modeling with evergreen 3D city models to harden infrastructure from flood and other natural hazards, and to apply engineering simulations for mitigation and emergency response; and
- *Resource conservation:* Taking full advantage of our solutions can significantly increase efficiency and reduce waste. For instance, our water network modeling tools, applied to compare as-designed specifications to observed flows and pressures, can help to non-invasively locate subsurface water network leaks.

### *Infrastructure Digital Twins.*

Our digital twins offerings enable our users to create and curate cloud-native 4D digital representations of physical projects and resulting assets, incorporating underlying engineering information, and then to model, simulate, analyze, chronicle, and predict performance over time. Using digital twins, our users can more fully extend digital workflows across project delivery and asset performance, increasing the value of infrastructure engineers' work.

Benefits of our digital twins solutions to project delivery firms and owner-operators include:

- *Advanced insights.* For project delivery, digital twins can reveal insights beyond what would be visible with traditional workflows; for example, a digital twin can show 3D heat maps highlighting where changes in a design have been unusually pervasive, indicating possible design flaws. For asset performance, such insights from digital twins can be used to evaluate different strategies for optimizing operational efficiencies and throughput;
- *Predictive analytics.* For project delivery, digital twins and machine learning can compare the progress of a current project with similar projects that have been previously completed, and identify in advance potential bottlenecks, in time to take corrective action. For asset performance, a digital twin can track observations from various operational inputs against design intelligence to predict future failures and recommend maintenance actions to minimize downtime;
- *Continuous and comprehensive design reviews.* For project delivery, digital twins can aggregate and align design models and data from all sources “on the fly” (without interruptions for translations, and without specialized software) to present immersive 3D status visualization in a web browser for any authorized stakeholder to participate in ongoing interactive design reviews; and
- *Convergence of OT, IT, and now ET.* Infrastructure owner-operators are increasingly able to instrument their assets with IoT sensors, producing torrents of OT data that are difficult to interpret. Software advances in IT can in turn make data from enterprise transaction systems, such as maintenance work order history, accessible for analytics. But even OT and IT together cannot inform decisions for improved asset performance as sufficiently as when combined with accessibility to comparable analytics from the assets' engineering models, which we refer to as the ET. Infrastructure digital twins notably enable the convergence of ET with OT and IT. With infrastructure digital twins, the design intent (the “digital DNA” captured in the digital twins' engineering models and simulations) can serve as a baseline for comparison to IoT-monitored “as-operated” performance, in light of the asset's operations and maintenance history stored in IT systems, to enable integrated analytics to provide timely insights and recommended actions to optimize safety and performance.

### **Comprehensiveness of Our Offerings**

Our offerings are comprehensive across professional disciplines, lifecycle stages, infrastructure sectors, and geographies, resulting in what we believe to be durable competitive advantages:

***Professional Disciplines.*** Each infrastructure project requires seamless and deep collaboration among professional disciplines, which can include civil, structural, geotechnical, and process engineers, architects, geospatial professionals, city and regional planners, contractors, fabricators, and operations and maintenance engineers. Our open modeling and open simulation applications facilitate iterative interactions between disciplines and coordination across project participants. Additionally, we believe our collaboration systems lead the market in managing infrastructure engineering firms' preferred work-in-progress workflows.

For example, to illustrate the benefits of interdisciplinary digital workflows in roadway design, our offerings' comprehensiveness can enhance both safety and economics by enriching the interfaces between geotechnical (earthworks) and structural analyses to share full 3D modeling details. Previously, structural decisions tended to be based on just a single imported parameter for subsurface foundation strength, frequently resulting in designs that included specifications and reinforcing materials beyond what was necessary to sufficiently mitigate risk.

The importance of integrating our offerings broadly across disciplines is also a reason that we have always prioritized interoperability with competitors' design tools. For major projects, owners and their

contractors want to have the choice of the best professionals in every discipline, rather than limiting their choices to those using a particular software vendors' applications. Our offerings win acceptance within major organizations and projects both through our breadth of applications, and through each application's virtuosity in interpreting and emulating formats beyond our own.

**Lifecycle Stages.** Both project delivery enterprises and owner-operators benefit from our solutions, which enable digital workflows to extend between project and asset lifecycles, from design to construction and ultimately asset management. This capability allows our users' digital engineering models to be leveraged as the context for real-time condition monitoring to achieve better and safer operations and maintenance.

For an example of advantageous digital workflows from projects to assets, consider our solutions for permitting and routing of over-weight and over-sized loads by departments of transportation. Instead of routing based merely on static maximum load ratings for each bridge, we use actual bridge design models for dynamic structural simulations, and 3D clearances of the actual load configurations. As a result, user organizations are able to engineer safe routes to maximize commerce while protecting bridge longevity.

**Infrastructure Sectors.** Most major engineering and project delivery firms pursue an ever-changing mix of projects across the public works/utilities, industrial/resources, and commercial/facilities sectors and for flexibility tend to favor an infrastructure engineering software vendor whose portfolio correspondingly spans their full breadth. This comprehensiveness provides diversification for our own business, as an incidental advantage. For example, when there have been cyclical downturns in the primarily privately-financed industrial/resources and commercial/facilities sectors, we have historically witnessed offsetting counter-cyclical government investment in public works/utilities.

**Geographies.** While design codes may vary by country, infrastructure purposes and engineering practices are fundamentally the same throughout the world, which makes it possible for our infrastructure modeling applications to be used globally. Our offerings are available in most major languages, supporting country-specific standards and conventions. Our development teams are also globally dispersed, due in part to acquisitions made in various countries, but also to provide any needed last mile localization of our applications. Our global comprehensiveness enables our project delivery accounts to compete more efficiently across geographic markets, thus also providing global supply-chain sourcing choices for owners.

### **Key Trends Impacting Our Markets**

#### ***Growth in Global Infrastructure Demand***

We expect that the rate of new spending required to meet currently anticipated infrastructure demands will represent a highly significant economic opportunity globally for the next twenty years. According to Oxford Economics' *Global Infrastructure Outlook* in 2017 (the "Oxford Economics Outlook"), in 2015, global spending was \$2.3 trillion across road, electricity, rail, telecoms, water, airports, and ports. Oxford Economics Outlook forecasts that this spending will increase to an average of \$3.2 trillion annually for the period from 2016 to 2040.

The increased demand for infrastructure is attributable to various factors, including urbanization and adaptation to demographic and climate changes. According to the Oxford Economics Outlook, by 2040, 10% of the world's population, and 15% of the population of Asia, will move into cities or find that their environs have newly become cities, and Asia will continue to account for over 50% of anticipated global infrastructure spending, with China alone accounting for 30%.

Over the period from 2016 through 2040, the Oxford Economics Outlook estimates that approximately \$79 trillion will be spent across road, electricity, rail, telecoms, water, airports, and ports, equivalent to approximately 3.0% of global GDP over the same period, broken down by purpose as follows:

Sector	Roads	Electricity	Rail	Telecoms	Water	Airports	Ports
2016-2040 Spending as Approximate Proportion of Global GDP	1.0%	1.0%	0.4%	0.3%	0.2%	0.1%	0.1%

The Oxford Economic Outlook estimates that an additional \$3.5 trillion of spending would be required to meet the UN's Sustainable Development Goals by 2030 for universal access to drinking water, sanitation, and electricity. Of this amount, \$1.9 trillion is identified as needed to increase drinking water and sanitation capacity.

The Oxford Economics Outlook quantifies a funding gap by which its predicted actual spending falls short of what it estimates to be the need for functionally sufficient public works/utilities infrastructure. For North America, South America, and Central America, that gap is 47%, suggesting that investment needs in such regions are 47% greater than forecasted investment under current trends. We believe this funding gap, given compelling economic rates of return on further infrastructure investment, will give rise to rapidly increasing private infrastructure financing.

We believe that infrastructure funding gaps will accelerate demands for infrastructure engineering going digital. While significant privately-sourced capital has been earmarked for infrastructure investment, much of those funds are being held as dry powder, with investors seeking attractive projects with sufficient predictability at the outset and sufficient visibility throughout their investment holding periods. We also believe that digital twins can help to meet these requirements for private infrastructure investment and fulfill private infrastructure investors' expectations of advancement in digital workflows across project and asset lifecycles.

### ***Responsibility for Environmental Sustainability***

The global infrastructure engineering community is resolutely taking on the challenges of reducing waste and emissions, improving resilience, and designing for adaption to climate change. Going digital is recognized as essential to accomplish these goals, including in the following respects:

- *Reducing carbon impact of new projects.* During project delivery, digital twin technologies are being used to calculate the carbon impact of material, design, and construction alternatives to minimize the emission of carbon dioxide and other greenhouse gases;
- *Minimizing carbon emissions of operating assets.* Simulations and asset performance solutions based on engineering models enable adapting existing assets to be more energy-efficient and/or less reliant on fossil fuels;
- *Increasing the substitution of renewable energy.* In addition to designing new renewable energy assets including wind, solar, hydro-power, and waste-to-energy plants, engineers are leveraging network performance solutions to modernize existing power grids to purposefully incorporate distributed energy resources;
- *Optimizing the use of natural resources.* Simulation and analysis applications help engineers, among other examples, to
  - optimize the framing of an asset to maximize structural resilience while minimizing the raw material required;
  - identify and locate leaks in water networks to save water and the electricity needed to pump it; and
  - efficiently engineer wastewater treatment and water reclamation plants to save water resources; and
- *Building resilience into cities and assets.* Engineers today can model the impact of floods, earthquakes, hazardous spills, and extreme weather, and can accordingly harden infrastructure to minimize risks and mitigate the damage, disruption, and losses associated with such events.

### ***Industrialization of Infrastructure Projects***

While digital technologies have long and continuously improved the economics of manufacturing, infrastructure owners and investors are becoming increasingly dissatisfied with the low productivity improvements and rampant schedule and cost overruns too often associated with infrastructure project delivery. Owner-operators have tended to allow each engineering design to start from scratch, without taking

into account potential synergies with the owner’s existing asset fleet, operational performance history, and knowledge from comparable assets, thereby limiting opportunities for lifecycle-cost breakthroughs from construction-driven and operations-driven design.

Infrastructure engineering organizations are increasingly acknowledging imperatives for going digital to address these inefficiencies. New strategies are focused on the “industrialization” of infrastructure design and construction, using a smaller palette of modular functional elements dictated by the owner, fabricated offsite for economy, quality, and safety, and transported and assembled onsite. In construction, industrialization portends automation and robotics with digitally controlled machinery, which is already underway for heavy civil earthmoving.

We believe that industrialization of infrastructure delivery is compelling and inevitable, and will lead owner-operators to harness their own operating asset performance analytics to direct their project supply chains to learn from and deliver digital twins along with physical assets. We also believe industrialization’s success will drive, and depend on, the adoption of 4D digital workflows for conception through construction, the comprehensiveness of all participants’ solutions, and connectedness both in their data environments and between asset and project lifecycles.

#### ***Key Developments Impacting Infrastructure Owner-Operators***

Trends that are influencing owner-operators’ requirements for infrastructure engineering software include:

- *Autonomous vehicles.* We believe that the increase in investment in and demand for autonomous vehicle technologies will drive the need for intelligent roadway infrastructure. Roadway and related infrastructure owners will likely need to actively participate, creating an opportunity for roadway digital twins;
- *Ubiquitous connected devices.* We believe that owner-operators are increasingly looking to third parties to maximize their use of new technologies such as IoT and 5G, which will help them propel their businesses to innovate further and go digital. For example, in bridge structural monitoring, machine learning applied to video of deflections during truckload passage can be as effective as sophisticated instrumentation with an array of sensors in detecting structural deficiencies;
- *Innovative funding models.* Newer forms of funding may catalyze the adoption of digital twins. For example, property tax proceeds can be increased based on building improvements that are machine-learned from aerial imagery; and
- *Threats to critical infrastructure.* Certain vulnerabilities, such as risks to the electric grid or potable water sources, represent potential use cases for digital twins for planning and execution of hardening, monitoring, and emergency response. Additionally, the requirement for industrial-strength cybersecurity for infrastructure digital twins will raise the barriers for entry, favoring world-class proprietors.

#### ***Key Developments Impacting Infrastructure Project Delivery Organizations***

Despite the potential upside in business outcomes presented by going digital, engineering and construction organizations face challenging constraints:

- *Business model obsolescence.* Traditionally, most engineering firms have relied primarily on the first phase of owners’ “design-bid-build” procurement models, billing for their design hours and leaving owners to retain the resulting cost and change risks associated with actual project delivery. We believe that owners increasingly prefer procurement models with some extent of integrated project delivery including construction, and they are increasingly open to financing models such as public-private partnerships, which focus on delivering both project and asset outcomes efficiently over a full asset lifecycle. As a result, both engineering and construction firms are increasingly under pressure to embrace integrated project delivery systems to share their work effectively, rather than accepting risks outside their domain or losing the work to integrated competitors;
- *Recruitment constraints.* Engineering firms are each challenged to compete for increasingly scarce local engineering skills and talent. In order to grow, these firms realize they need to be going digital,



substituting technology for labor, and charging for increased value despite decreasing labor hours. Over time, however, we believe that as the infrastructure engineering professions fully adopt digital twin infrastructure engineering software, which is more visually immersive and interactive, their work will become relatively more appealing to “digital native” generations of potential engineering talent;

- *Globalization of competition.* New technologies have enabled engineers around the world to contribute to projects located in other countries. Using these technologies, foreign firms are able to bid aggressively and win work elsewhere, and even domestic competitors have established value engineering centers in overseas locations where engineering skills are relatively abundant, inexpensive, and digitally advanced. We believe that many firms in established markets recognize that going digital is essential both to maximize their local productivity and to fully integrate with virtualized collaborators worldwide;
- *Capital constraints.* In general, design and construction firms have not presented a compelling opportunity for investors, given their relatively higher risks and lower returns relative to other investment opportunities, and hence tend to be thinly capitalized. These firms require digital solutions, but often do not have the financial capital or technical resources to attempt to self-develop them. As a result, design and construction firms are increasingly a large and ready market for infrastructure engineering software, especially offerings with open-source capabilities for firms to configure and brand their own digital-twin offerings and analytics; and
- *Digital silos.* Legacy software applications often produce static deliverables in one-time, one-way file formats, siloed from the digital workflows required to bridge disciplines and lifecycle phases. Competitiveness in today’s project delivery market requires solutions that facilitate data created by one application (for instance, in design) serving as inputs in new automated workflows by other applications (for instance, in 4D construction modeling). Such digital workflows improve productivity and quality, helping project delivery enterprises toward replication so that every project performs as well as their best projects.

#### **The Digital Twins Opportunity**

We believe that digital progress in infrastructure advancement has to date lagged behind other economic domains for several reasons, including that:

- most existing infrastructure assets predate engineering modeling software;
- engineers’ work, including by way of building information modeling (“BIM”) or geographic information systems (“GIS”), has been sequestered in native file formats that amount to “dark data,” inaccessible without the software that was used to create it, and therefore unavailable for use in digital workflows or analytics; and
- construction processes are often fragmented and isolated from digital workflows altogether, resulting in engineering information being effectively abandoned between the project and the asset lifecycle phases of infrastructure.

Over our company’s history, as computing capabilities have advanced, the scope of infrastructure engineering software has correspondingly increased. However, project lifecycle and asset lifecycle software markets have developed independently from one another and connecting digital workflows have not been offered. We believe that the new advancement of BIM and GIS to “evergreen” infrastructure digital twins will have the effect of merging what have to date been separate market spaces.

Period	Project Lifecycle Software	Asset Lifecycle Software
1985 – 1995	<p><i>2D Drafting (“Computer Aided Design,” or “CAD”):</i> Workstations and then personal computers make possible interactive graphical applications to automate the creation of previously manually drafted 2D engineering drawings.</p>	<p><i>2D Mapping:</i> Workstations and personal computers make possible interactive graphical applications to automate the creation of maps.</p>
1996 – 2005	<p><i>Collaboration:</i> Networked personal computers and servers provide platforms for file-sharing and referencing. Common Data Environments (“CDEs”) are introduced.</p>	<p><i>Geographic Information Systems (“GIS”):</i> Networked personal computers and servers enable querying and visualization of geographic data.</p>
2006 – 2015	<p><i>3D BIM:</i> Increased personal computing power enables the development of 3D applications for design of specific asset types including buildings, process plants, roads, water networks, and buildings. CDEs and the internet lead to global work-sharing and collaborative BIM.</p>	<p><i>Geospatial:</i> Increased computing address space enables geo-coordinated engineering models. GPS technology enables alignment of digital components and real-world coordinates.</p> <p><i>Asset Performance Management (“APM”):</i> solutions are introduced for reliability-centered maintenance and risk-based inspection.</p>
2015 – 2018	<p><i>Reality Modeling:</i> Advances in digital imagery, unmanned aerial vehicles (“UAVs,” or “drones”), and specialized software enable the automated capture of as-operated conditions of an asset or site in an engineering-ready, geo-coordinated 3D model. Cloud ubiquity enables <i>Common Data Environments</i> to evolve into <i>Connected Data Environments</i>.</p>	<p><i>APM</i> evolves into <i>Asset Performance Modeling</i>, with engineering models recalibrated to reproduce and understand observed behaviors, and apply algorithms and analytics to derive insights and drive decisions.</p>
2019 – Present	<p><i>4D Digital Twins:</i> Digital twins make possible the simulation of the behavior and the visualization of the changes of a project or infrastructure asset over time. Digital twins are continually updated in a cloud database and remain current and “evergreen,” over the full project and asset lifecycle, through continuous surveying of the physical context and embedded links to inputs from connected IoT sensors in the operating asset. With digital twins, users are empowered to better understand the impact of changes over time for projects and assets to improve project, construction, and operational efficiencies, predictability, and overall outcomes.</p>	

To enable infrastructure engineering to catch up and advance in “going digital,” we have enabled infrastructure digital twins, cloud-provisioned digital representations of projects and assets that incorporate and converge their 3D physical conditions (“digital context”) for reality, their underlying engineering information (“digital components”) for veracity, and their 4D timeline of changes (“digital chronology”) for fidelity, enabling the merging of project lifecycle and asset lifecycle workflows.

## Digital Twins Requirements and Benefits

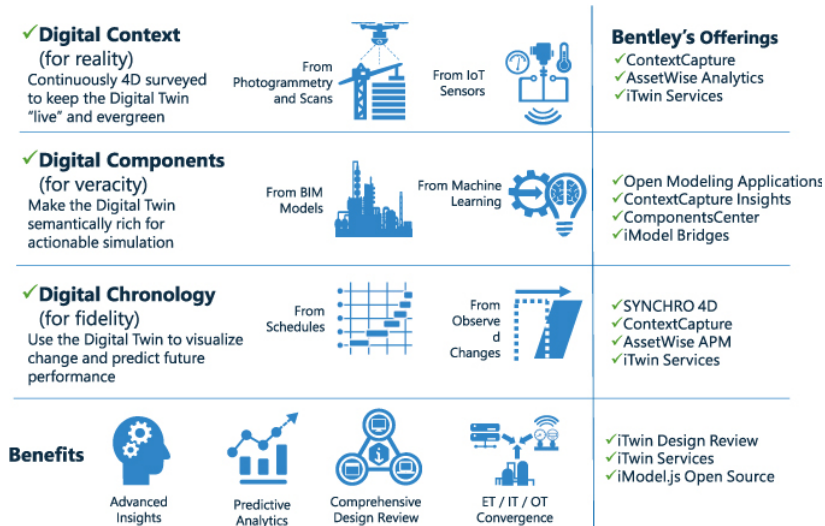

Digital twins solutions are now made possible by new technologies including UAVs and their intrinsic “surveying” sensors, machine learning, cloud computing, open-source development libraries, distributed ledger software, and mixed-reality visualization.

Our software to leverage these advancements for our digital twins offerings includes:

- **Reality modeling software**, which processes any combination of overlapping digital photography, video, and scanned imagery to produce a 3D model. Our software then uses machine learning to recognize and classify components within the 3D model (such as equipment, structural elements, pipes, valves, tags, and nameplates). This process populates the digital twins’ digital context with digital components that add intelligence, especially when aligned with engineering models from the design stage;
- **iModel distributed databases**, which combine and align the digital components from all available sources for infrastructure projects and/or assets. iModels are created and bridged to our iTwins cloud services from our own engineering applications or from third-party applications. Using our iModel distributed databases, “dark data” is opened and aligned semantically and spatially with all other relevant models, allowing this information to be accessed and for its value to be enhanced; and
- **iTwins cloud services**, which update distributed databases through change ledgers to synchronize digital twins, as required, with physical and engineering changes. Along with assuring that their fidelity can be relied upon for critical decisions, our iTwins cloud services maintain secure environments for infrastructure digital twins’ visualization and analytics visibility. Our iTwin services can be added to any user’s or accounts’ environments to generate incremental value by incorporating infrastructure engineering data within cloud-native evergreen digital twins. The go-to-market strategy for our iTwin cloud services is based on a dual-pronged sales strategy:
  - Sales to enterprise accounts using ProjectWise and AssetWise, to more broadly propagate their project and asset engineering data, respectively, through iTwins Design Review Service for comprehensive project-wide 4D status visibility, Immersive Asset Services, and PlantSight; and
  - Sales to individual practitioners and their workgroups for ad-hoc iTwins Design Review Service, often to upgrade their use of 2D PDF tools to 3D.

We believe that the growing adoption of infrastructure digital twins will serve to overcome the factors that have held back the digital advancement of infrastructure engineering. Moreover, we believe that due to the comprehensiveness of our solutions across project and asset lifecycles, infrastructure digital twins and

newly enabled digital workflows spanning design, construction, and operations, will most particularly benefit our users and enhance our competitiveness.

### **Our Opportunity**

We believe we are successful and well-established in enterprise-level relationships with the world's largest infrastructure engineering organizations, including both project-delivery contracting firms and owner-operators. Today, we address a significant SAM. We estimate 66% of our SAM is in our existing accounts. We further estimate our global SAM is approximately \$9.5 billion, \$6.1 billion of which is attributable to project delivery firms and \$3.4 billion of which is attributable to owner-operators. Further, of our \$9.5 billion SAM, approximately \$1.6 billion is in Greater China.

We also view our market opportunity in terms of the TAM, which we believe we can address over the long term. We believe that digital progress in the engineering of constructed infrastructure has to date lagged behind other substantial economic domains and, in particular, has lagged behind digital progress — as reflected in spending on engineering software — in the engineering of manufactured products.

Over time, as project delivery firms and owner-operators increasingly recognize the value of going digital and increase their spending on infrastructure engineering software solutions, we believe that the “intensity” of infrastructure engineering software spending will approach the “intensity” of product engineering software spending, as measured by spend per engineer (or engineering technician, in each case).

Cambashi quantifies our TAM as what would be the total spend for infrastructure engineering software solutions if the intensity of infrastructure engineering software spending would become equivalent to that of product engineering software spending. This TAM value is derived by banding countries by intensity of product engineering software spend, and multiplying average product engineering software spend levels per product engineer (or product engineering technician) by the total number of infrastructure engineers (and infrastructure engineering technicians) for each respective band. In 2018, global infrastructure engineering spend for an estimated 22.5 million engineers totaled \$8.3 billion. In the same year, global product engineering total spend for an estimated 11.1 million engineers totaled \$13.9 billion.

Cambashi accordingly estimates that if engineering software spending would become as intensive per engineer (or engineering technician) in infrastructure engineering as in product engineering, global infrastructure engineering software spending would be \$29.2 billion. We believe that over time our current SAM of \$9.5 billion will approach this estimated TAM of \$29.2 billion. We also believe that both our SAM and our TAM will further expand over time with the growth of infrastructure spending.

In order to estimate our SAM of \$6.1 billion for project delivery accounts, we consider both project delivery organizations whose design and construction billings are reported to and published by ENR in addition to smaller project delivery organizations that do not have billings reported and published by such an organization. We estimate that the SAM for the larger project delivery accounts that have billings reported and published by ENR is currently approximately \$3.4 billion.

We estimate that the SAM for the smaller project delivery accounts is currently approximately \$2.7 billion. Our calculation of the metric for the larger project delivery accounts that have billings reported to and published by ENR is based on the percentage of ARR/billings we capture from these larger accounts relative to the total billings from these accounts based on data reported to and published by ENR. This method results in a penetration rate that we apply across all of the accounts published by ENR. We use this same penetration rate to estimate the SAM for smaller project delivery organizations that do not report or publish billings in ENR.

In order to estimate our SAM of \$3.4 billion for owner-operator accounts, we consider both larger owner-operators that are included in the list of *Bentley Infrastructure Top 500 Owners* in addition to smaller owner-operators that are not included in our list. We estimate that the SAM for the larger owner-operator accounts included in the list of *Bentley Infrastructure Top 500 Owners* is currently approximately \$1.6 billion. We estimate that the SAM for smaller owner-operators not included in the list of *Bentley Infrastructure Top 500 Owners* is currently approximately \$1.8 billion. Our calculation of this metric is based on the percentage of ARR/billings we capture from these larger accounts relative to the net infrastructure asset value of the accounts included in the list of *Bentley Infrastructure Top 500 Owners*. This results in a

penetration rate that we apply across all of the larger accounts included in the list of *Bentley Infrastructure Top 500 Owners*. We use this same penetration rate to estimate the SAM for smaller owner-operators not included in the list of *Bentley Infrastructure Top 500 Owners*.

Over time, we believe our SAM and TAM will expand from increased infrastructure spending. Moreover, in Asia, where the Oxford Economics Outlook estimates a majority of infrastructure spending occurs already and expects spending to increase through 2040, digital twin approaches are now being pursued to rapidly supersede traditional workflows institutionalized elsewhere in the world. In fact, in our 2019 Year in Infrastructure awards, the winners for 15 of 26 categories, judged by independent juries of global experts, were projects in China, India, Pakistan, and Southeast Asia, where we see spending on digital solutions accelerating faster than in other parts of the world.

### **Our Growth Strategies**

We employ the following growth strategies to address the infrastructure engineering software market opportunities:

- ***Accretion within existing accounts.*** Most of our accounts currently use a small portion of our overall portfolio, even though they are often working on projects and assets where a large portion of our portfolio could be applied. We believe we can further penetrate our existing accounts by broadening their use of our portfolio. There are three primary mechanisms for this expansion:
  - ***New commercial formulations.*** We continually innovate with new commercial formulations to align the use of our software to the needs of our users. Presently, we offer our subscription solutions by the day, month, quarter and year. Additionally, we offer options enabling unrestricted access to our comprehensive software portfolio. We believe the flexibility in our commercial models and deployment options will allow our accounts to grow usage continuously;
  - ***Automating user engagement.*** We employ various technologies to drive user engagement. These technologies help to automate the user experience and drive engagement by suggesting and recommending best practices and appropriate software upgrades. We will continue to leverage these interactive technologies to virtually assist our users and drive engagement across our software offerings; and
  - ***Adding new offerings.*** We have a history of building and maintaining leadership in infrastructure software engineering comprehensiveness and intend to continue to innovate and develop our software offerings. Selected recent examples of our product innovations include the 2019 introduction of new multi-disciplinary modeling and simulation applications for 5G-ready communications towers and for offshore wind turbines, and the 2019 integration of our acquisitions of new software for vehicle traffic simulation and mobile mapping. Over the near term, we believe our iTwins Cloud Services represent a compelling opportunity to enhance value for our accounts. We intend to continue to develop and integrate new products and capabilities over time;
- ***Focusing on Asia.*** We believe Asia represents a large market opportunity and will continue to do so over the foreseeable future. According to the Oxford Economics Outlook, a majority of expected infrastructure spending for the period between 2016 and 2040 is expected to occur in Asia. Additionally, we believe that in Asia there is an abundance of skilled engineers whose work can be virtually exported, as well as engineering organizations that are eager and aggressive to win mandates for engineering and construction projects around the world. We intend to continue investing in strategies to enhance our market position in Asia;
- ***Increasing inside sales.*** Historically, our account management resources have focused on larger firms. Smaller and medium-sized engineering firms, however, represent a significant market opportunity and have the same needs for our comprehensive portfolio as the larger firms. While these firms have generally been served by our competitors' channel partners, we believe they will prefer to deal directly with us. We will continue to expand our global inside sales resources and to multiply their reach and effectiveness with superior digital tools to convert leads and to provide the self-service administration that engineering practitioners prefer; and

- **Digital co-ventures.** We have forged substantial alliances with other major participants in the infrastructure engineering supply chain, primarily to jointly develop and offer digital twin cloud services that extend the scope of our software. These alliances include:
  - Siemens: Our partnership integrates leading industrial software and IoT capabilities for a broad joint development program focused on improving outcomes during infrastructure operations and maintenance through digital workflows enabled by digital twins cloud services; and
  - Microsoft: Our partnership extends Azure-powered machine learning and analytics through digital workflows for infrastructure professionals and enterprises.
- **Investing in digital integrator businesses.** We intend to invest in and grow a portfolio of businesses operating outside of our core software business with the objective of cultivating an ecosystem of relatively service-intensive, digital integrator businesses that stimulate pull-through demand for our solutions. These investments may take the form of acquisitions, wholly owned start-up initiatives, minority equity stakes, alliances or loans. Certain of our recent digital integrator activities include:
  - Digital Construction Works: Our partnership with Topcon Positioning Systems integrates leading surveying technologies and geospatial machine control technologies for digital workflows between engineering and usage in the field. Our companies’ Digital Construction Works joint venture provides expert services to major project delivery enterprises to incorporate these constructioneering workflows.
  - The Cohesive Companies: These investments, spawned by our acquisition of Cohesive Solutions in 2020, focus on enterprise asset management, asset performance, and digital twin integration services.
  - Digital Water Works: This wholly-owned start-up initiative focuses on the implementation, integration and adoption services necessary to establish digital twin solutions for water and waste water utilities.

We anticipate each of the foregoing digital integrator businesses will become part of our Acceleration Fund portfolio of investments, which we expect to establish and operate distinctly inside of Bentley Systems, Incorporated.

**Our Software Offerings**

Our software products’ development and go-to-market strategy are organized within Design Integration applications and Project Delivery systems (for project lifecycles), and Asset and Network Performance systems and Digital Cities applications (for asset lifecycles), all supplemented and brought together with our digital twins (“iTwins”) cloud offerings.

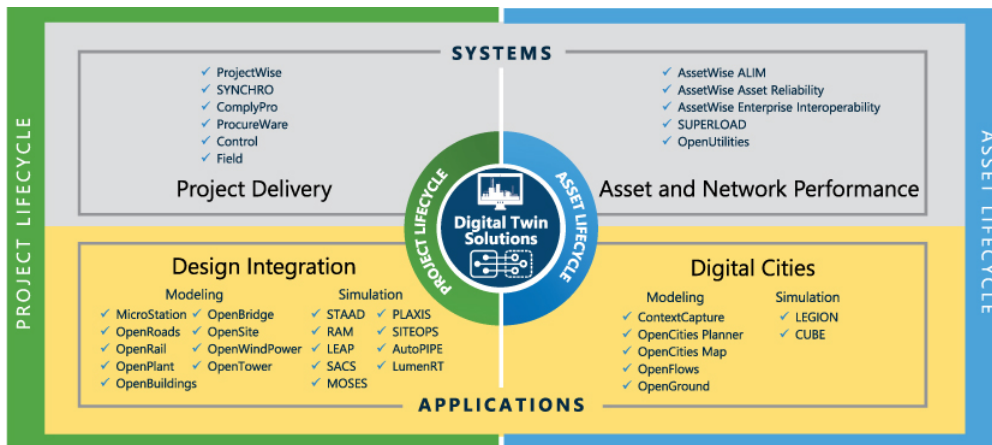

### ***Design Integration Applications***

We undertake to provide comprehensive open modeling and open simulation applications for infrastructure design integration. Our open modeling applications include:

- *MicroStation*, for flexible 3D design and documentation providing the common modeling environment upon which our applications are built;
- *OpenRoads*, for the planning, 3D design, and documentation of roads and highways;
- *OpenRail*, for the planning, 3D design, and documentation of rail and transit systems;
- *OpenPlant*, for the 2D and 3D design and documentation of process plants;
- *OpenBuildings*, for the 3D design, and documentation of buildings and their integrated structural, HVAC, electrical, and plumbing systems;
- *OpenBridge*, for the 3D design and documentation of bridges;
- *OpenSite*, for the optimal planning, 3D design and documentation of building, residential development, and infrastructure sites;
- *OpenWindPower*, for the design of fixed and floating wind turbine structures; and
- *OpenTower*, for the design of communications towers, including for 5G capacity.

Our open simulation applications include:

- *STAAD* and *RAM*, for analysis and simulation respectively of infrastructure and building structural performance;
- *LEAP* and *RM*, for analysis and simulation of bridge structural performance;
- *SACS*, for analysis and simulation of offshore structural performance;
- *MOSES*, for analysis and simulation of floating structures;
- *PLAXIS*, for geotechnical analysis and simulation of subsurface rock and soil interacting with infrastructure foundations, footings, pilings, and tunnels;
- *SITEOPS*, for simulation of compliant site layout, and optimization of earthworks, drainage, and parking;
- *AutoPIPE*, for analysis and simulation of pipe stress in industrial process plants; and
- *LumenRT*, for enlivened animations of infrastructure projects.

### ***Project Delivery Systems***

Our Project Delivery solutions support collaboration, work-sharing, and 4D construction modeling for infrastructure project delivery enterprises. These offerings include:

- *ProjectWise*, for helping teams to manage, share, and distribute work-in-progress engineering content. *ProjectWise* enables all stakeholders involved in design and engineering to share and find information, conduct collaborative design reviews, and manage contractual exchanges faster for maximum team productivity;
- *SYNCHRO*, for planning 4D construction models for project and field management, work packaging, and immersive visualization, for instance via Microsoft HoloLens;
- *SYNCHRO ConstructSim*, for advanced work packaging, including engineering, construction, and installation work packages, and trade and task workface planning; and
- Additional cloud services for specialized project delivery use cases, including *ComplyPro*, *ProcureWare*, *Control*, and *Field*.

### ***Asset and Network Performance Systems***

Our Asset and Network Performance solutions, including our *AssetWise* systems, manage geo-coordinated information for asset performance modeling throughout the operations and maintenance lifecycle of infrastructure assets and their associated networks, in transportation, energy, and communications. These offerings include:

- *AssetWise ALIM*, for managing infrastructure asset information and linear networks and for controlling and managing change over the asset lifecycle;
- *AssetWise Asset Reliability*, for reducing equipment downtime and limiting business risk associated with equipment failures, while increasing safety, reliability, and cost effectiveness;
- *AssetWise Enterprise Interoperability*, for enabling access to multiple data sources from third-party providers, and integrating them in operations and maintenance workflows;
- *SUPERLOAD*, for automating the safe routing and permitting of overweight/oversized vehicles;
- *AssetWise 4D Analytics*, for employing advanced analytics and machine learning, particularly to IoT time series, to gather insights to understand current conditions and predict future performance;
- *AssetWise Linear Analytics*, for visualizing and understanding vast quantities of linear network data to identify trends and anomalies, and optimize maintenance decisions, for rail or road networks; and
- *OpenUtilities*, for the design and management of electric, gas, and district energy networks, and substations.

### ***Digital Cities Applications***

Our Digital Cities offerings are used for surveying, reality modeling, planning, and managing the geospatial infrastructure of cities and regions. These offerings include:

- *ContextCapture*, for surveying existing conditions of a city, construction site, or operating infrastructure asset by processing digital imagery captured by UAVs, cameras, and scanners into 3D, geo-located, engineering-ready mesh models, and providing the digital context for digital twins;
- *ContextCapture Insights*, for applying machine learning, through cloud computing, to automatically identify and classify recognizable components in reality modeling;
- *OpenCities Planner*, for engineering-ready geospatial urban planning and visualization;
- *OpenCities Map*, for engineering-level GIS functions such as mapping, cadaster, and parcel management;
- *OpenFlows*, for water, wastewater, and stormwater system planning, design, and operations, incorporating hydrological, hydraulic, and flood modeling;
- *OpenGround*, for geotechnical information management;
- *CUBE*, for vehicular traffic simulation in roadway design; and
- *LEGION*, for pedestrian traffic simulation.



### Applications and Systems Revenue Mix

Our 2019 revenues attributable to our applications and systems are set forth in the chart below.

### 2019 Revenues by Applications and Systems

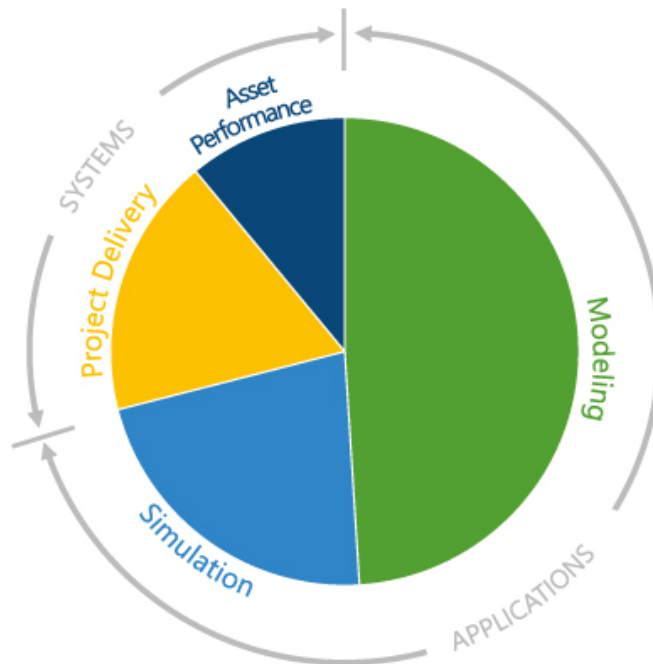

\* All figures calculated using ASC 606.

### iTwins Cloud Offerings

Our iTwins cloud offerings add digital twins capabilities to any account's environment. These include:

- *iTwins Design Review Service*, for browser-level immersive status visualization, ranging from ad-hoc 2D/3D discipline-specific workflows for any applications users, to *ProjectWise*-enabled 4D design reviews and analytics visibility spanning the full project scope;
- *Immersive Asset Service*, for 4D immersive visualization and analytics visibility for *AssetWise* users;
- *OpenUtilities Digital Twin Cloud Services*, for consolidating, validating, and aligning GIS, reality modeling, performance, simulation, and other data for energy and communications networks; and
- *PlantSight*, for live and evergreen digital twins of operating process plants. PlantSight is jointly developed by Bentley and Siemens and commercially available from either company.

### Use Cases

Our applications and systems are used in combinations, in parallel and in sequence, for infrastructure projects and assets.

#### Project Lifecycle Use Case

The following example illustrates the comprehensive use of our offerings in the planning, design, and construction of a new highway overpass to accommodate increased traffic at an intersection in a growing part of a city:

At the start of the project, *ProjectWise* is set up for the project team as a structured repository for their engineering work and shared documents and models relevant to the overpass project. The physical conditions of the current roadway intersection are surveyed with drones and captured with *ContextCapture* to produce the accurate 3D model which will be the basis for the engineering work. For the planning of the overpass, *OpenRoads ConceptStation* enables the roadway designers to quickly iterate on different overpass configurations and get preliminary estimates of the construction costs of various scenarios. *OpenSite* and *PLAXIS* is used by geotechnical engineers for modeling the geotechnical properties of the site to ensure the subsurface conditions for the roadway and overpass are accurately considered in the proposed design. Visualizations and animation of the proposed design alternatives are generated by *LumenRT* for city and community reviews and approvals.

When the preliminary design is approved, *OpenRoads Designer* begins to produce the detailed design of the ramps and roadway directly from the *ConceptStation* files. Bridge engineers use *OpenBridge Modeler* to quickly evaluate various options for the overpass bridge, then *OpenBridge Designer* is used to produce the detailed design of the bridge. *LEAP* is used to model and simulate the bridge's structural performance and compliance with building codes. Throughout the detailed design phase, as the project team grows and the complexity of the design develops, *ProjectWise* supports the work-sharing for the team, manages the production and distribution of the project deliverables, and helps resolve design clashes among elements of the multidisciplinary design.

In the construction phase, as the project team expands to include contractors and subcontractors, detailers, and fabricators, *ProjectWise* coordinates and provides an audit trail of the distribution of documents and approvals, ensuring the right team members have the right information at the right time. The construction management team uses *SYNCHRO 4D* to take the 3D models of the project and assign sequencing attributes to the various constructible elements, creating a 4D construction model used to evaluate different construction sequences during planning, and to track the progress of the actual construction through to completion. *SYNCHRO ConstructSim* is used to automate the detailed workforce planning to create work packages of trades, materials, and schedules for each step and each section of the construction project.

When the construction planning is complete and the roadway and ramp grading is ready to begin, the project terrain model created by *OpenRoads Designer* is exported via *ProjectWise* to Topcon's *Magnet* software, which drives the GPS-enabled grading machinery to grade the surface of the site earthworks to the exact elevations of the design model. As the construction progresses, UAVs with *ContextCapture* continuously surveys the site to enable our solution's reality modeling capabilities to track the volume of soil still to be cut and filled, and monitor the actual progress to determine the "earned value" for contractor payments.

#### *Asset Lifecycle Use Case*

When the roadway overpass project is complete and operational, our Asset Lifecycle solutions can help keep its infrastructure in peak performance:

*AssetWise Asset Reliability* manages the inspection and inventory of all types of transportation infrastructure assets, including bridges, culverts, signs, light poles, antenna towers, stormwater networks, guardrails, retaining walls, and other ancillary structures. UAVs with *ContextCapture* continuously survey the roadway and overpass and use machine learning to identify storm drains that are clogged or road surface cracks and potholes needing repair and *AssetWise Enterprise Interoperability* alerts enterprise maintenance systems to issue work orders for repairs.

Sensors on the overpass bridge provide performance data to the asset performance digital twin and *AssetWise 4D Analytics* compares the observed performance to the predicted performance of the digital twin and spots trends for future performance, ensuring the safe operation of the bridge. *SUPERLOAD*, which maintains a cloud database of the dimensions and structural capacities of all the bridges in the state, further supports the operation of the overpass by permitting and routing over-sized and overweight vehicles to ensure those vehicles can safely cross the bridge, or have the clearance to drive under it, without damage to the vehicle or the bridge.

As the city grows, *CUBE* simulates the increase in vehicular traffic in different areas and *AssetWise Linear Analytics* analyzes the road network and projects the impact of increased traffic on the overpass. *Linear Analytics* also indicates the impact of a lane closure due to construction or an accident and provides alternate routing to alleviate congestion. When road construction involves subsurface utilities, *OpenUtilities* provides accurate documentation to the field to locate and identify the utility networks in the construction zone and analyzes the water pipe networks to help pinpoint the source of leaks. If there is flooding due to a water main break or an extreme weather event, *OpenFlows FLOOD* models the extent of flooding over the timeline of the event and determines its impact on the roadway and overpass.

*AssetWise ALIM* tracks and manages all of the overpass and roadway network asset information, ensuring that changes over its lifecycle are recorded and those affected by the impact of those changes on the entire road network are notified. *ALIM* streamlines the data analysis and reporting required for compliance with local, regional, and national transportation authorities.

## **Our Commercial Offerings**

### ***Licensing Models***

Our applications are offered through perpetual licenses or term licenses, priced dependent on the country of purchase and use. Most accounts owning perpetual licenses subscribe to our SELECT coverage which, in addition to providing support and upgrades, enables the use of their licenses for each product to be pooled within each country. For most larger accounts (generally a minimum of \$250,000 ARR) we have traditionally offered an ELS, which entitles unlimited use of any of our applications for an annual fixed fee, reset annually generally based on actual usage (within each country) for the previous year. During the fourth quarter of 2018, to respond to and improve upon new commercial models offered by peers and competitors, we introduced a new global consumption-based plan with consumption measurement durations of less than one year, E365, which is priced uniformly per application per day of actual usage in any country, and inclusive of Success services (described below) by our colleagues to assist with expanding and gaining the most value from usage of our software. We have begun upgrading ELS accounts to E365, beginning with the largest global accounts.

## Revenues by Commercial Model

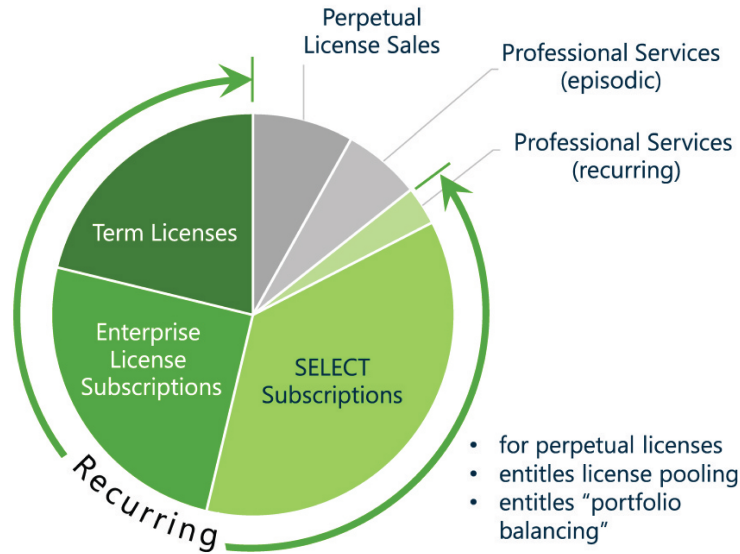

\* All figures as of December 31, 2019. All figures calculated using ASC 606. Chart segment sizing corresponds to underlying % of 2019 revenue.

Our systems, *ProjectWise* and *AssetWise*, are offered under our CSS program, charged quarterly based on actual users of “passports” and “visas” for various levels of functionality. Passport and visa pricing include Azure provisioning at our cost, although some accounts elect to continue on-premises and/or hybrid hosting. CSS commercial models entail an annual funding commitment, generally paid upfront, based on an estimation of services to be used for the upcoming year. Actual consumption is monitored and invoiced against the deposit on a calendar quarter basis. Accounts are charged only for what gets used, and deposited amounts never expire. At the end of 2019, accounts comprising approximately 58% our total ARR had chosen to institute our new commercial models of CSS and/or E365 consumption funding for licensing of our software.

### Success Plans

Over the past several years we have re-deployed the post-sale focus of our success force, comprising more than 900 colleagues with experience and credentials in infrastructure engineering, from on-demand professional services and training to instead fulfill “Success Plans.” Through Success Plans, we assume proactive responsibilities to accounts to maximize their value from our solutions, which we accomplish by assigning our success force experts to be dedicated to serve multiple accounts requiring similar specializations. Typically, our success force engages with our accounts remotely. Success Plans are bundled into our new E365 commercial program and are growing rapidly among our major accounts.

Our success force also provides:

- *Managed services*, under Service Level Agreements (“SLAs”), to administer accounts’ instances of our Azure-provisioned *ProjectWise* and/or *AssetWise* systems. SLAs vary as to our scope of responsibility, sometimes including Success Plans and/or our colleagues dedicated onsite;
- *Professional services*, mainly for implementation and integration of our *ProjectWise* and *AssetWise* systems within substantial enterprises, although we seek to minimize the need for this; and
- *Digital Advancement Academies*, where we convene industry participants to share best practices, including in programs with major owner-operator accounts to onboard their supply chains for initiatives in going digital.

## **Our Accounts**

We provide our software solutions to over 34,000 accounts in 172 countries worldwide. Our revenues are balanced and diversified between engineering and construction contracting firms who work together to deliver the design and construction of capital projects (representing 54% and 55% of our 2018 and 2019 revenues, respectively), and their clients, the world's public and private infrastructure asset owners and operators (representing 46% and 45% of our 2018 and 2019 revenues, respectively).

We do not have material account concentration. No account, including any group of accounts under common control or accounts that are affiliates of each other, represented more than 2.5% of our revenues in 2018 or 2019.

## **User Case Studies**

Examples of the value of Bentley's infrastructure engineering software solutions for the design, construction and operations of critical infrastructure include:

### ***Case Study: Italferr S.p.A.***



### **Italferr Comprehensively Leverages Bentley's Design Integration Solutions for Project Digital Twin in Critical Infrastructure Project**

#### *The Challenge*

Following the tragic collapse of the Morandi Bridge in Genoa, Italy in 2018, Italferr S.p.A. was commissioned to develop the engineering design of the new viaduct over the Polcevera River. The viaduct forms a critical link in the region's transportation system and economy, which made it imperative to apply the latest technology to speed the design and construction of the replacement bridge. The project had to be tackled in innovative ways to ensure the speed of modeling and design decisions, with the requirement to complete the detailed engineering design in about three months, and the construction completed less than two years after the collapse. This meant that engineering workflows and construction workflows that are typically sequential had to be done in parallel to meet the extraordinary timeline for the engineering of the 1067-meter-long viaduct.

#### *The Solution*

Italferr turned to Bentley's design integration portfolio for the multi-disciplinary engineering of the viaduct and ProjectWise's connected data environment for project team collaboration, enabling the various engineering teams to seamlessly integrate their BIM models. Bentley's reality modeling solution was used to quickly perform aerial LIDAR surveys of the site to automatically generate digital terrain models from the aerial imaging, and Italferr used Bentley's geotechnical modeling applications to model the subsurface conditions. As the roadway alignment was being engineered with OpenRoads, another part of the design team modelled the structural, HVAC, and electrical systems as generative components, leveraging the inherent computational design capabilities in OpenBuildings' GenerativeComponents technology. Since the sizing, angle, and orientation of these components were all driven by the geometry of the centerline alignment for the viaduct's roadway, these computational design capabilities meant that the model and its related documentation could be automatically updated as the roadway alignment geometry or other governing geometry was updated to optimize the design.

With the ProjectWise connected data environment as the collaboration and data federation hub for the project, it enabled digital workflows to keep the project digital twin continuously up-to-date, and to find and resolve clashes between the various components while still in the engineering phase. From the project digital twin, a 4D construction digital twin was created using SYNCHRO to strategize, visualize, and industrialize the construction sequence for optimal outcomes — as the concrete piers were being erected,

the steel cross-sections of the decking spans could be fabricated offsite, transported to the construction site, assembled on the ground, then lifted in place onto the piers.

#### *Added Benefits*

The project digital twin also made it possible to extract volumes and quantities from the model which, when they were systematically organized into schedules, allowed the total cost of the work to be precisely defined. Italferr also is working to create an asset performance digital twin of the new viaduct to be used in the operation lifecycle, complete with information useful for organizing and managing maintenance. This objective will allow the digital twin model to leverage the digital components of the BIM model for use in operations and maintenance, linking the digital twin to IoT sensors monitoring the bridge performance to ensure its operational performance and safety. The project includes the construction of a photovoltaic system with an output power of 136 kW to use renewable energy to power the safety monitoring systems as well as the lighting, controls, and drainage equipment of the viaduct.

#### *Account Growth*

Italferr has been using Bentley's civil engineering solutions for more than ten years, and since 2016 has expanded their adoption of Bentley offerings to include ProjectWise and a comprehensive portfolio of design integration applications.

#### *Case Study: Shell*



### **Shell Advances to 4D Construction Digital Twins with Bentley's Reality Modeling**

#### *The Challenge*

To help in realizing its goal of building the "plant of the future" for a multi-billion-dollar chemical plant in western Pennsylvania, Shell wanted to regularly survey the construction site to track and improve the progress of the project, but because of the scale of the 386-acre site, and the inherent safety challenges in surveying an active construction site, conventional surveying methods were not feasible. To meet this challenge, Shell turned to Bentley's ContextCapture software.

#### *The Solution*

UAVs (Unmanned Aerial Vehicles) equipped with digital cameras perform at least weekly photographic surveys on the site and upload nearly 8,000 digital photos to Bentley's ContextCapture cloud service, which automatically processes the 2D images into a 3D "reality mesh." The reality mesh is dimensionally accurate and engineering-ready, making it an effective digital twin of the physical construction site. A new digital reality mesh is generated on a weekly basis, maintaining a 4D construction digital twin, enabling the engineering and construction teams to monitor the actual construction progress over time in comparison to planned progress.

The Shell project team has worked with Bentley on a bi-monthly basis to use the digital twin and Bentley's flood modeling application, OpenFlows FLOOD, to simulate the effects of heavy rainfall events resulting in potential flooding on the site. The results enable Shell Construction management to devise strategies to mitigate potential disruption to the construction schedule, swiftly re-planning workfront activities as well as assessing any environmental damage.

#### *Added Benefits*

The digital twin of the construction project was also instrumental in enabling the project team to identify and resolve potential construction clashes in near-real-time, helping keep the project on track. In

addition, the project team used the reality meshes to monitor soil erosion, manage construction materials inventory, improve emergency response management, and identify potential hazards. The digital twin will facilitate safe plant operations, for instance through the accurate 3D location of underground piping, based on the capture of reality meshes for reference prior to trenches being filled in.

The continuous surveying of the existing site conditions ensures that the 4D construction digital twin always mirrors the current status, which is made securely accessible to the project teams via a web browser and immersive visualization. This allows Shell stakeholders, and the engineering, procurement, and construction (EPC) contractors, to optimize their collaboration and decision-making based on an up-to-date, single view of physical reality in relation to the 4D project plan.

#### *Account Growth*

The use of ContextCapture and OpenFlows FLOOD adds to Bentley applications and systems cumulatively used for Shell projects and assets by its engineering, construction and plant operations groups. For example, Shell engineers use STAAD, SACS and MOSES for onshore and offshore structural simulation respectively, AutoPIPE for plant pipe stress simulation and PLAXIS for geotechnical engineering. In construction, Shell and EPC contractors use SYNCHRO Advanced Work Packaging for workforce planning, achieving significant improvements in “hands-on-tools time.” In operations, AssetWise Reliability solutions have been applied to improve operational uptime. Spanning the project and asset lifecycles at mega-scale, Shell facilities benefit from ProjectWise and AssetWise connected data environments and are most recently leveraging Bentley’s iTwin services to open up the “dark data” from other vendors’ plant design applications.

#### *Case Study: Shenzhen Expressway Engineering Consultants Co., Ltd.*



### **Shenzhen Expressway Engineering Consultants Leverage iTwin Technology for Delivery of Complex Highway Interchange**

#### *The Challenge*

The east grade-separated interchange engineering of Yan’gang in Shenzhen, Guangdong, China, was initiated to accommodate the convergence of four high-speed roadways, which transport cargo from the Shenzhen Yantian Port and is a connector for high-speed traffic to the downtown area. The complex interchange network runs 10.5 kilometers in length, including 10 new ramps, 16 bridges, and eight tunnels and underpasses. The RMB 1.47 billion project is one of the key demonstration projects chosen by the People’s Republic of China’s Ministry of Transport (MOT) to serve as a benchmark for innovation in the design, engineering, and construction of traffic infrastructure in Shenzhen. As the leading unit of the MOT’s BIM Industry R&D Center, Shenzhen Highway Engineering Consultants is responsible for project delivery of the interchange, and for establishing a BIM and digital twin methodology throughout the entire project lifecycle that will become a model for the whole traffic engineering industry in Guangdong. The project scope includes the integrated site and multi-disciplinary highway engineering, the coordination and management of the large volume of data from multiple sources, including teams responsible for land acquisition and site demolition, and oversight of the complex construction works, while ensuring that the project meets the highest standards of quality, safety, cost management and timely completion.

#### *The Solution*

In addition to a comprehensive set of Bentley’s open modeling applications and the ProjectWise collaboration system, the Shenzhen Expressway Engineering team used Bentley’s iTwin technology to create project and construction digital twins to analyze several traffic relief and interchange design schemes for an optimal design and construction plan. With an engineering and construction project this complex, it is essential that changes in any of the engineered systems (including earthworks, subsurface drainage networks, road and bridge foundations and superstructures, and roadway alignments), be communicated and

synchronized to the entire project team, and that any potential physical clashes among these systems by identified and resolved prior to construction.

UAVs used Bentley’s reality modeling solutions, enabling continuous surveying of the site to monitor the construction progress. Bentley’s design integration and project delivery solutions, in concert with Bentley’s iTwin technology, facilitated real-time collaboration, change synchronization, and data access, identifying and proactively resolving over 60% of site interference problems to avoid construction delays and cost overruns. Through a 4D construction digital twin created with SYNCHRO, the team simulated virtual on-site construction to verify workflows and meet the 35-month construction schedule.

#### *Added Benefits*

The aggregation of data from multiple sources in the digital twin, and making that data open to analytics and accessible to project stakeholders, has provided valuable business and engineering insights to keep the project on track. For example, according to the actual conditions at site as continuously surveyed through reality modeling, the management team can analyze the observed progress deviation from schedule and can rationally allocate the manpower, material, machines and other resources to keep the project on schedule and on budget. The digital twin is providing the visibility needed to make its supervision more efficient — the industry supervision organizations, the owner, and the third-party survey company can assess the performance of each party in this project, and can initiate ratification notices and link it with the model, making the whole process online and transparent. In addition, through the innovative application of digital twin, it has been possible to achieve positive results in both energy saving and environmental protection. Upon completion, the “digital DNA” of the digital twin will be seamlessly reconfigured as an asset performance digital twin for the complete operations and maintenance lifecycle.

#### *Account Growth*

Beginning with their first use of Bentley’s civil engineering solutions in 2017, Shenzhen Expressway Engineering Consultants have expanded their adoption of Bentley’s full project delivery and asset performance solutions portfolio and is now one of the leading consumers of Bentley’s iTwin technology.

#### *Case Study: Águas do Porto*



### **H2PORTO, A Technological Platform for the Integrated Management of the Urban Water Cycle**

#### *The Challenge*

Águas do Porto is a water utility company providing service and management of the urban water cycle in Porto, the second largest city in Portugal. With nearly 157,000 customers, Águas do Porto currently manages 818 kilometers of water mains, 558 kilometers of foul water sewers, and 661 kilometers of storm water drainage pipes, in addition to 66 kilometers of streams and 3.4 kilometers of seafront. Águas do Porto has installed and manages data from 34,000 smart water meters on customer properties and has over 350 telemetry and telecontrol devices installed throughout its network, a number that continues to increase.

Águas do Porto was challenged with finding a better way to manage the vast number of infrastructure assets and water resources required to manage the city’s water cycle and to integrate, manage and analyze a huge amount of data collected from many sources with numerous existing, and sometimes incompatible, software systems. To meet this challenge, the company began development of H2PORTO, a technology platform for the integrated management of the urban water cycle. The overarching goals of the project are to promote a culture of innovation and smart water management for the efficient usage of existing resources and to achieve better overall asset management and service.



### *The Solution*

OpenFlows, OpenFlows WaterGEMs, and OpenFlows FLOOD were used for the design, configuration, implementation, and automation of all the modeling and predictive capabilities, and for the creation of a digital twin of the city's water supply, wastewater, stormwater, and bathing water systems, to forecast flooding and water quality issues, and to improve service response and resilience. The predictive models automatically generate daily forecasts and publish the results in the project platform. Bentley consultants also developed services for on-demand, online simulation analysis of network changes resulting from pipe bursts, valve closures, and pumping station shutoffs.

The H2PORTO platform incorporates all data gathered from more than 22 different sources, including billing, meters, sensors, operations, SCADA, weather stations and traffic control systems. Integrating all this data in an agnostic technological platform management system, the company created a powerful tool that enables better and more reliable water service and achieves more structured and effective communication and collaboration for 400 internal users, customers and other stakeholders. The platform relies on the identification of issues related to common standards and processes for data provision, communication amongst technological platforms, business intelligence tools, and decision making through the analysis of data, modelling tools and predictive analysis, striving to better inform its citizens.

### *Added Benefits*

The digital twin of the water system has evolved to an *asset performance digital twin*. The insights gained from the digital twin enable the team to adjust their asset management strategies every day, allowing for more sustainable asset planning. The digital twin helps engineers and technicians to investigate and analyze the networks in more detail and from different perspectives, with room for tests and simulations that are not achievable in real-life scenarios. The modeling of flooding and pollution events specifically empowers the teams with the information they need to take the necessary actions to prevent damage or harmful incidents before they occur. Since 2016, the rate of water meters replacement almost doubled, the average duration of pipe bursts repairs improved by 8%, and water supply interruptions and malfunctions in water mains both decreased about 20%.

### *Account Growth*

Águas do Porto has been a user of Bentley's solutions since 2013.

### **Our Technology**

Our business is singularly focused on software for infrastructure engineering, primarily for the world's largest projects and assets. As a result, we manage our software products to meet constraints imposed for fitness to this purpose. Our market position is built on several reputational hallmarks, including:

- generational stability of file formats, corresponding to the long lives of infrastructure projects and assets;
- commitment to openness and interoperability with competitors' file formats;
- continuity of software applications' lifecycles, never jeopardizing users' cumulative investments by requiring them to "start over"; and
- highest capacity and performance, versus competitors, for large infrastructure models and datasets.

### *Application Framework*

Our software solutions are delivered using flexible, reusable, and open technology, which results in highly integrated applications and cloud services that support comprehensive digital workflows in a scalable manner. For example, our modeling and simulation applications, including MicroStation, leverage a set of reusable components for graphics editing, visualization, solid modeling, and other capabilities. This open framework supports the addition of domain specific features, allowing us to offer highly compatible and well-integrated discipline-specific applications based on this common framework.

*Microsoft Integration*

Our software leverages Microsoft’s platform technologies. We seek to take full advantage of integration with Microsoft Office 365 and other horizontal applications such as Teams for workflows that unify our engineering applications within enterprise environments across all computing form factors and devices.

*iModels and iModelHub*

We support a rich format for digital twins called an iModel, a relational database encapsulated in a file, that stores aligned domain data from multiple source applications. iModels are synchronized with our design applications and we provide software development tools to enable iModels to be synchronized with third-party applications or services. We have created and maintain iModel connections to most of the significant applications used in infrastructure engineering. iModels provide a common data currency to support open and easy exchange between users and systems, and we believe that they have become a de facto standard for visibility and collaboration of digital engineering models. iModelHub, an iTwin cloud service, manages each iModel as a distributed database with an intrinsic ledger of changes (enabling alignment, accountability, and accessibility of digital components over the lifecycle of a project or an asset) to form the backbone of an infrastructure digital twin. To foster an expanded ecosystem of digital twin innovation, our iModel.js code is available on GitHub as an open source library under the MIT license.

*Our Licensing and Administration Platform*

All of our applications and systems share a cloud-native platform for license pooling, management of subscription entitlements, and usage reporting for us and for accounts, including for commercial consumption metrics. Our platform also logs usage of particular “instrumented” functions within our applications to enable our success force to be of most value. Our platform can also provide in-application messaging to users from our success force.

**Our Acquisitions**

Since our founding, we have purposefully pursued a strategy of regularly acquiring and integrating specialized infrastructure engineering software businesses, including 18 acquisitions over the past five years. Our average historical annual revenue growth rate from acquisitions over the last six years has been approximately 1.1%. Our acquisitions have the following purposes:

- filling in the breadth and depth of our comprehensive applications portfolio across disciplines and infrastructure sectors, especially where the developer organizations have already worked on integration and compatibility with our platforms and APIs;
- extending our lifecycle comprehensiveness, especially for our Asset and Network Performance, and Digital Cities product advancement units;
- adding new horizontal technologies that we can incorporate within our platforms for the benefit of our applications and systems at large, such as reality modeling; and
- adding new distribution capacity, such as to channel partners in geographies where we wish to accelerate our scale and growth.

Our executive management and our Portfolio Development team proactively identify and develop potential acquisition subject areas and unsolicited candidates. We also are prepared, experienced, and able to respond with agility when appropriate situations may appear opportunistically. We have a disciplined and proprietary diligence and valuation process for evaluating acquisition targets. Our general practice is to fully assimilate the acquired companies’ functions into our global functional structure as quickly as possible, supported by a dedicated team to manage and streamline the integration process.

We prioritize the retention and development of the acquired incoming colleagues from our acquisitions, including offering talent mobility for key personnel. Further, many of our current line executives are former founders and/or C-level officers of companies we have acquired.

Examples of key recent acquisitions, along with their purposes, include:

- *PLAXIS* (2018), *SoilVision* (2018), and *Keynetix* (2019), to become what we believe be a world leader in geotechnical engineering modeling and simulation software and in geotechnical information management;
- *SYNCHRO* (2018), to become a leading provider of 4D construction modeling software;
- *ACE Enterprise* (2018), to integrate our systems with enterprise environments such as SAP and IBM's Maximo;
- *Citilabs* (2019), to add vehicle traffic simulation software (CUBE) and roadway movement data (Streetlytics) to lead to improved mobility digital twins for Digital Cities;
- *OrbitGT* (2019), to add specialized capabilities for mobile mapping (such as vehicle-based scanning and photogrammetry) to our reality modeling offerings for Digital Cities;
- *GroupBC* (2020), to bring additional common data environment solutions for construction projects and infrastructure assets, and federate to iTwin cloud services, extending the value of project and asset information through digital twins; and
- *Cohesive Solutions* (2020), to bring digital integrator expertise for the convergence, through digital twin cloud services, of digital engineering models (ET), with IT and OT, for infrastructure assets in the utilities, energy and facilities sectors.

### **Our Competition**

The market for our software solutions is highly competitive and subject to change. We compete against large, global, publicly-traded companies that have resources greater than our own, and also against small, new, or geographically-focused firms that specialize in developing niche software offerings. While we do not believe that any competitor offers a portfolio as comprehensive as ours, we do face strong competition, varying by infrastructure lifecycle phase and sector:

- our key competitors in **public works/utilities applications** include Autodesk, Inc., Trimble Inc., Hexagon AB, and Dassault Systèmes;
- our key competitors in **industrial/resources applications** include Hexagon AB and AVEVA Group plc;
- our key competitors in **commercial/facilities applications** include Autodesk Inc., Nemetschek SE, and Trimble, Inc.;
- our key competitors in **project lifecycle systems** include Autodesk, Inc. and Oracle Corporation with their Primavera P6 and Aconex offerings; and
- our key competitors in **asset lifecycle systems** include Aspen Technology, Inc., AVEVA Group plc, Environmental Systems Research Institute, Inc., and General Electric Corp.

The principal competitive factors affecting our market include:

- product features, performance, and effectiveness;
- reliability and security;
- product line breadth, depth, and continuity;
- comprehensiveness of offerings across disciplines and infrastructure sectors;
- specification by and endorsement of infrastructure owners, and degree of adoption across the relevant supply chain;
- familiarity and loyalty by professionals throughout their training and careers;
- ability to integrate with other technology;
- capacity to operate at scale;
- capabilities for configurability and APIs;

- ease of use and efficient workflows;
- price, commercial model, and total cost of use;
- support of industry standards;
- strength of sales and marketing efforts; and
- brand awareness and reputation.

We believe we compete favorably against our competitors based on the factors above and that we distinguish ourselves through our comprehensive software portfolio, our commitment to both integration and interoperability across the entire infrastructure lifecycle, our flexible commercial models, and our direct sales channels.

### **Our Sales and Marketing**

We bring our offerings to market primarily through direct sales channels that generated approximately 92% of our 2019 revenues. Our direct sales channel includes:

- Corporate Account Managers, who are responsible for our largest accounts;
- Inside Sales Specialists, who are responsible for servicing small-to mid-sized (“commercial”) accounts in territories defined by geography and product lines; and
- Product Sales Specialists, who are technical experts in a specific product line who work with Corporate Account Managers and Inside Sales Specialists.

We rely on specialist channel partners in geographic regions where we do not currently have a meaningful presence and where, for many of our offerings, direct sales efforts are less economically feasible. Channel partners accounted for approximately 8% of 2019 revenue. We are establishing digital integrators such as Digital Construction Works to serve as global channel partners. In addition, we have established a new business endeavor, DXW+, which offers practitioner subscriptions that include virtual support and advice from DXW’s engineering experts. DXW+ is available in selected and expanding geographies, and for individual professionals in any organization. We also benefit from additional sales resources and coverage from our digital co-venturers through various forms, including bundles of our offerings with theirs.

Sales cycles for our applications tend to be relatively short, measured in weeks. The most prevalent transactions are increases by accounts in their use of our applications already in use. Our sales model allows and encourages accounts to try usage of our applications that are new to them with minimal obligation. We act upon our logs of such new usage to assign user success colleagues to help the new users in this expanded adoption.

Our system offerings, *ProjectWise* and *AssetWise*, are generally sold through either proactive proposals or responses to RFPs, so sales cycles for those offerings range from months to several quarters. We have a comprehensive global proposals team to assure appropriate business development resources are allocated, to quality-assure efficient and effective proposal contents, and to maximize the capture ratio for our proposal pursuit.

Our marketing functions include:

- *corporate marketing*, to build brand awareness, brand equity, and thought leadership, including through corporate events and programs covering industry trends and challenges, and to conduct market research and industry studies;
- *industry and product marketing*, for demand generation through digital marketing channels, including our website, Internet advertising, webinars, and virtual events, and paid and organic social media, and through traditional marketing channels such as trade print advertising, press releases, editorial placements, industry-specific trade shows and conferences, in-person seminars, and locally-sponsored events; and
- *regional marketing*, to localize and deliver our marketing programs throughout the world.

We also invest in our annual Year in Infrastructure Conference, which brings together leading infrastructure thought leaders from around the world for presentations on innovative projects, to learn about the latest advances to our applications and cloud offerings, and to network and share best practices. Our associated Year in Infrastructure Awards, which in 2019 attracted over 500 project nominations from our accounts and are judged by independent juries in approximately 20 categories for going digital in infrastructure engineering.

### **Our Research and Development**

We continue to make substantial investments in research and development because we believe the infrastructure engineering software market presents compelling opportunities for the application of new technologies that advance our current solutions. Our research and development roadmap balances technology advances and new offerings with continuous enhancements to existing offerings. Our allocation of research and development resources is guided by management-established priorities, input from product managers, and user and sales force feedback.

We had approximately 1,500 colleagues engaged globally in software research and development as of December 31, 2019. Each of our product advancement groups for Design Integration, Project Delivery, Asset and Network Performance, and Digital Cities have research and development resources and responsibilities. Our iTwin Services group consists of over 275 colleagues and is entirely devoted to the rapid development of new and incremental cloud-native services for infrastructure digital twins. Our separate Chief Technology Office assesses the potential of new software technologies and sources.

As part of our resource allocation process, we also conduct a cost-benefit analysis of acquiring available technology in the marketplace versus developing our own solutions. Our Portfolio Development office, in addition to pursuing appropriate acquisitions and digital-integrator startups, allocates funding for internal “acceleration” projects, to “make” rather than “buy.” Each such project is staffed with colleagues dedicated to the “intrapreneurial” incubation of a new offering, which is brought back to its respective sponsoring product advancement group after market introduction.

For the years ended December 31, 2017, 2018, and 2019, and for the six months ended June 30, 2020, our research and development spending was \$151.2 million, \$175.0 million, \$183.6 million, and \$89.4 million, respectively, and as a percentage of total revenues was 24.0%, 25.3%, 24.9%, and 23.6%, respectively.

#### *Digital co-ventures*

In 2019, we and Topcon created an equally-owned joint venture, Digital Construction Works, Inc. to serve as a digital integrator for major construction projects and related enterprises. We and Topcon each contributed experienced colleagues in addition to the required capital commitments.

As part of our co-venturing with Siemens, we undertake a program of joint research and development investment in which each company bears its own costs. These investments have led to jointly offered cloud services for infrastructure digital twins, some of which are already commercially available. We and Siemens have committed to a cumulative investment of over €100 million to fund the joint innovation investment program.

### **Our Talent and Our Values**

As of June 30, 2020, we had 4,010 full-time colleagues. Our colleagues are located in 42 countries, including 1,568 in the Americas, 1,183 in EMEA, and 1,259 in APAC. We embrace diversity among our colleagues, who collectively bring 64 languages to fulfill the needs of our globally dispersed accounts and users. Our colleagues are highly qualified with an average of seven years of total service with the Company and advanced academic credentials, including 90 doctoral degrees and 1,046 master’s-level degrees.

We believe our culture and values are key to our mission and key to our success in competing to attract and retain highly talented colleagues. Our culture and values include a motivation to make an impact on the world’s infrastructure to improve quality of life, a passion to solve our users’ challenging problems through innovation and creativity, a desire to connect and collaborate, and a commitment to deliver on our promises.

In addition to competitive compensation and benefit programs, we support our colleagues' interests in their communities with civic outreach and corporate giving matching programs, as well as an annual stipend for every colleague globally to support their choice of investment in Science, Technology, Engineering, and Math (STEM) programs.

None of our colleagues in the United States is covered by a collective bargaining agreement. We have never experienced a strike or similar work stoppage, and we consider our relations with our colleagues to be favorable.

### **Our Intellectual Property**

We believe that the success of our business depends more on the quality of our proprietary software solutions, technology, processes, and domain expertise than on copyrights, patents, trademarks, and trade secrets. While we consider our intellectual property rights to be valuable, we do not believe that our competitive position depends primarily on obtaining legal protection for our software solutions and technology. Instead, we believe that our competitive position depends primarily on our ability to maintain a leadership position by developing innovative proprietary software solutions, technology, information, processes, and know-how. Nevertheless, we rely on a combination of copyrights, patents, trademarks, and trade secrets in the United States and other jurisdictions to secure our intellectual property, and we use contractual provisions and non-disclosure agreements to protect it. As of December 31, 2019, we had 116 patents granted and 53 patents pending in the United States, the first of which expired on May 24, 2020, and 21 patents granted and 33 patents pending internationally, the first of which expires on August 14, 2022. In addition, from time to time we enter into collaboration arrangements and in-bound licensing agreements with third parties, including certain of our competitors, in order to expand the functionality and interoperability of our software solutions. We are not substantially dependent upon any one of these arrangements, and we are not obligated to pay any material royalty or license fees with respect to them.

Our patents cover systems and methods relating to various aspects of software for infrastructure design and modeling, collaboration and work sharing and infrastructure asset operations. Among other things, our patents address a broad range of issues in infrastructure domains from analyzing building energy usage and structural analysis, railway system maintenance, water network design and operation and augmented reality, as well as techniques for creating, storing, displaying, and processing infrastructure models.

To innovate and increase our strategic position, our software developers are incentivized to alert our internal patent committee to innovations that might be patentable or of strategic value. In 2019, our patent committee reviewed 20 invention disclosures submitted by our software developers, and filed 25 U.S. and eight foreign patent applications, while 16 U.S. and three foreign patents were granted. We also plan to assess appropriate occasions for seeking patent and other intellectual property protections for aspects of our technology and solutions that we believe constitute innovations providing significant competitive advantages. We have registered 129 trademarks, including "Bentley," "MicroStation," "AssetWise," and "ProjectWise," with the U.S. Patent and Trademark Office and in several jurisdictions outside the United States.

Our names, logos, website names, and addresses are owned by us or licensed by us. This prospectus contains trademarks, trade names, and service marks of other companies, which are the property of their respective owners. Solely for convenience, trademarks, and trade names referred to in this prospectus may appear without the ®, TM, or SM symbols, but the lack of those references is not intended to indicate, in any way, that we will not assert, to the fullest extent under applicable law, our rights or the right of the applicable licensor to these trademarks, trade names, and service marks. We do not intend our use or display of other parties' trademarks, trade names, or service marks to imply, and such use or display should not be construed to imply, endorsement or sponsorship of us by these other parties.

### **Our Facilities**

Our corporate headquarters are located in Exton, Pennsylvania and consist of 107,051 square feet of office space, 76,392 square feet of which we own. Our lease for the remainder expires in 2025. Our headquarters accommodates our principal software engineering, sales, marketing professional services, and administrative activities. For more information, see Note 5 to our consolidated financial statements included elsewhere in this prospectus. In addition to our headquarters, we own one other location in India, which is

used for office space, for an aggregate total, including our headquarters, of 106,392 square feet of real property owned by us. We lease facilities in an additional 96 locations across 36 countries.

We believe that our current facilities are suitable and adequate to meet our current needs and that suitable additional or substitute space will be available as needed in the future to accommodate our operations.

**Legal Proceedings**

We are subject from time to time to various legal proceedings and claims which arise in the ordinary course of our business. Although the outcome of these and other claims cannot be predicted with certainty, we do not believe that the ultimate resolution of pending matters will have a material adverse effect on our financial condition, cash flows, or results of operations. We currently believe that we do not have any material litigation pending against us.

## MANAGEMENT

### Executive Officers, Directors and Director Nominee

The following table sets forth the name, age, and titles of our executive officers, directors and director nominee as of the date of this prospectus:

Name	Age	Position
Gregory S. Bentley	65	Chairman, Chief Executive Officer and President
Keith A. Bentley	62	Chief Technology Officer and Director
Barry J. Bentley, Ph.D. <sup>(1)</sup>	64	Director
Raymond B. Bentley	60	Executive Vice President and Director
Kirk B. Griswold <sup>(1)</sup>	58	Director
Brian F. Hughes <sup>(1)</sup>	61	Director
Janet B. Haugen <sup>(2)</sup>	61	Director Nominee
David J. Hollister	55	Chief Financial Officer and Chief Operations Advancement Officer
David R. Shaman	54	Chief Legal Officer and Secretary

(1) Member of the Audit Committee.

(2) Will be a member of the Audit Committee upon the consummation of this offering.

The following includes a brief biography for each of our executive officers, directors and director nominee, with each director and director nominee biography including information regarding the experiences, qualifications, attributes or skills that caused our board of directors to determine that each member of our board of directors and director nominee should serve as a director as of the date of this prospectus.

**Gregory S. Bentley** has served as President and Chairman of our board of directors since June 1996 and Chief Executive Officer since August 2000. Prior to joining us in 1991, Mr. Bentley founded and served as Chief Executive Officer of Devon Systems International, Inc., a provider of financial trading software, which was sold to SunGard Data Systems, Inc. in 1987. Mr. Bentley served as a director of SunGard and a member of its audit committee from 1991 through 2005. He holds a B.S. in economics and an M.B.A. in finance and decision sciences from the Wharton School, University of Pennsylvania. He is a trustee of Drexel University.

We believe that Mr. Bentley is qualified to serve as a member of our board of directors due to the extensive and valuable business and managerial perspective he has and his significant experience in the software technology industry, together with a deep understanding of our history and commitment to the markets we serve.

**Keith A. Bentley** co-founded our Company and has served as a director since our inception in 1984. He previously served as the Company's President from 1984 to 1995 and as the Chief Executive Officer from 1984 to 2000. He currently serves as Chief Technology Officer, a position he has held since 2000. He holds a Bachelor's degree in electrical engineering from the University of Delaware and an M.S. in electrical engineering from the University of Florida.

We believe that Mr. Bentley is qualified to serve as a member of our board of directors due to the perspective and experience he brings as one of our co-founders and our Chief Technology Officer, and his experience in the software industry, especially as it relates to our technology and solutions.

**Barry J. Bentley, Ph.D.** co-founded our Company and has served as a director since 1984 and as an executive officer from 1984 through 2019. From September 1984 to June 1996, Dr. Bentley served as Chairman of our board of directors. Prior to co-founding our Company, in 1979, he co-founded and served as Vice President of Dynamic Solutions Corporation, a software firm. Dr. Bentley is one of the originators of MicroStation and was continuously involved in the planning and development of our software solutions



and technology since our inception through 2019. He holds a Bachelor's degree in chemical engineering from the University of Delaware and an M.S. and Ph.D. in chemical engineering from the California Institute of Technology.

We believe that Dr. Bentley is qualified to serve as a member of our board of directors due to his deep knowledge and understanding of the Company's technology, history, and mission as one of our co-founders, as well as his experience in the software industry.

**Raymond B. Bentley** has served as a director since May 2015 and has served as an Executive Vice President since 1984. He was the lead developer for MicroStation and chief architect in the core-graphics group. He holds a Bachelor's degree in mechanical engineering from Rensselaer Polytechnic Institute and an M.S. in computer engineering from the University of Cincinnati.

We believe that Mr. Bentley is qualified to serve as a member of our board of directors due to his vast experience with our technology and the software industry, and for the business perspective he brings to the board.

**Kirk B. Griswold** has served as a director since 2002. He is a Founding Partner of Argosy Capital Group, Inc., a private equity and real estate firm. He holds a Bachelor's degree in Physics from the University of Virginia and an M.B.A. with a dual major in Finance and Management from the Wharton School, University of Pennsylvania.

We believe that Mr. Griswold is qualified to serve as a member of our board of directors due to his extensive experience in engineering, project management, and consulting, as well as his knowledge and experience in finance.

**Brian F. Hughes** has served as a director since February 2020. He retired from KPMG LLP in 2019 where he was a partner from 2002 to 2019, serving as National Private Markets Group Leader from 2012 to 2019, National Co-Leader of KPMG's venture capital practice from 2009 to 2019, and the practice leader of the Technology and Venture Capital group of KPMG's Philadelphia office from 2002 to 2009. He began his career in 1981 at Arthur Andersen where he was elected partner in 1993. Mr. Hughes holds a B.S. in Economics and Accounting from the Wharton School, University of Pennsylvania and an M.B.A. from the Wharton School, University of Pennsylvania. He is also a licensed CPA.

We believe that Mr. Hughes is qualified to serve as a member of our board of directors due to his extensive financial and accounting experience with both private and public companies, as well as his understanding of public company audit and governance requirements and responsibilities.

**Janet B. Haugen** is a nominee to our board of directors and Audit Committee, whose formal election will occur upon the consummation of this offering. She previously served as the Senior Vice President and Chief Financial Officer of Unisys Corporation from April 2000 to November 2016. She also held positions as Vice President, Controller and Acting Chief Financial Officer of Unisys between April 1996 and April 2000. Prior to joining Unisys, she held positions at Ernst & Young from 1980 to 1996, including as an audit partner from 1993 to 1996. She currently serves on the board of directors, Audit Committee Chair and a member of the Compensation Committee of Paycom Software, Inc., a provider of comprehensive, cloud-based human capital management software, a position she has held since February 2018. Since May 2019 she has served on the board of directors of Juniper Networks, Inc., which designs, develops and sells high-performance network technology products and services, and as chair of the Audit Committee since February 2020. She also served on the board of directors and chair of the audit committee of SunGard Data Systems Inc., a software and services company, from 2002 to 2005.

We believe that Ms. Haugen is qualified to serve on our board due to her extensive leadership experience as an executive, financial expertise and public company governance experience as a current and prior member of the board of directors and audit committee chair of other public technology companies.

**David J. Hollister** has served as our Chief Financial Officer since 2007. In addition to providing financial leadership, Mr. Hollister is responsible for various aspects of our operations, including our IT and cloud hosting operations, financial operations, business intelligence, and portfolio development activities, including mergers and acquisitions and accelerated commercial development. Prior to joining our Company,

he was the chief financial officer and a member of the board of directors of Broder Bros., Co from 2004 to 2007. Mr. Hollister previously served as a director in the M&A Transaction Services practice at PricewaterhouseCoopers LLP, where he specialized in international transactions. He holds a Bachelor's degree in Business Administration from the University of Northern Colorado and an M.B.A. from the University of Michigan.

**David R. Shaman** joined our Company in 1998 and has served as our Chief Legal Officer since 2016. Mr. Shaman previously served as General Counsel from 2015 to 2016 and as Deputy General Counsel from 2006 to 2015. Prior to joining us, Mr. Shaman was an associate at the law firm Covington & Burling LLP. Mr. Shaman's international experience includes eight years leading the Company's legal operations outside the United States, as well as tenures at the European Commission, Directorate-General for Informatics in Brussels and Harlequin Limited, a software company in Cambridge, United Kingdom. He holds a Bachelor's degree in mathematics from the University of Pennsylvania, a J.D. from Harvard Law School, and a Diploma in Mathematical Statistics from Cambridge University.

### **Director Independence**

Rules 5605 and 5615 of the Nasdaq Listing Rules require that independent directors compose a majority of a listed company's board of directors within one year of listing. In addition, the Nasdaq Listing Rules require that, subject to specified exceptions, each member of a listed company's audit committee be independent and also satisfy criteria set forth in Rule 10A-3 under the Exchange Act. Under Nasdaq Listing Rule 5605(a)(2), a director will only qualify as an "independent director" if, in the opinion of the board of directors, that person does not have a relationship that would interfere with the exercise of independent judgment in carrying out the responsibilities of a director. To be considered independent for purposes of Rule 10A-3 under the Exchange Act, a member of an audit committee of a listed company may not, other than in his or her capacity as a member of the audit committee, the board of directors, or any other board committee: (1) accept, directly or indirectly, any consulting, advisory, or other compensatory fee from the listed company or any of its subsidiaries; or (2) be an affiliated person of the listed company or any of its subsidiaries.

Based upon information requested from, and provided by, each director and director nominee concerning his or her background, employment and affiliations, including family and other relationships, including those relationships described in the section titled "Certain Relationships and Related Party Transactions," our board of directors will have three independent directors. Our board of directors has determined that each of Kirk B. Griswold, Brian F. Hughes and Janet B. Haugen does not have a relationship that would interfere with the exercise of independent judgment in carrying out the responsibilities of a director and that he or she is "independent" as that term is defined under Rule 5605(a)(2) of the Nasdaq Listing Rules. Although the Nasdaq Listing Rules require that a majority of the board of directors be independent, because we will be a "controlled company" within the meaning of the Nasdaq Listing Rules, we are permitted to, and have elected to, not comply with this requirement. In addition, although the Nasdaq Listing Rules require that each member of our audit committee be independent, under special phase-in rules applicable to newly public companies, we will have until one year from the effective date of the registration statement of which this prospectus forms a part to comply with this independence requirement.

### **Controlled Company**

We are a "controlled company" under the corporate governance rules of the Nasdaq Listing Rules because the Bentley Control Group controls a majority of the voting power of our outstanding capital stock. Therefore, we are not required to have a majority of our board of directors be independent, nor are we required to have a compensation committee or an independent nominating function. In light of our status as a controlled company, our board of directors has determined not to have a compensation committee or an independent nominating function and to have the full board of directors be directly responsible for reviewing and approving compensation and benefit arrangements for our executive officers and directors, as well as for nominating members of our board of directors. Additionally, as described in the section titled "Description of Capital Stock — Anti-Takeover Provisions — *Certificate of Incorporation and By-law Provisions*," so long as the outstanding shares of our Class A and Class B common stock held by the Bentley Family represent a majority of the combined voting power of our common stock, the Bentley Family will

be able to effectively control all matters submitted to our stockholders for a vote, as well as the overall management and direction of our company.

#### **Compensation Committee Interlocks and Insider Participation**

We did not have a compensation committee during the last completed fiscal year and compensation of our executive officers was determined by our board of directors during the last completed fiscal year. None of our executive officers currently serves, or in the past year has served, as a member of the board of directors or compensation committee of any entity that has one or more executive officers serving on our board of directors.

#### **Election of Officers**

Our executive officers are elected by, and serve at the discretion of, our board of directors. Messrs. Gregory S., Keith A., and Raymond B. Bentley, each of whom is a director and executive officer of our Company, and Dr. Barry J. Bentley, a director of our Company, are brothers.

#### **Board of Directors**

##### ***Composition of our Board of Directors upon the Effectiveness of the Registration Statement of which this Prospectus Forms a Part***

Our amended and restated by-laws provide that the number of directors will be determined from time to time by resolution of our board of directors. Upon the effectiveness of the registration statement of which this prospectus forms a part, we will have six directors and by closing of this offering we will have seven directors.

Upon election, each director is elected for a one-year term and serves until a successor is duly elected and qualified. Any additional directorships resulting from death, resignation, increase in the number of directors or otherwise may be filled for the unexpired term by a majority vote of the remaining directors then in office. Directors may be removed with or without cause by the affirmative vote of a majority of the combined vote of our then-outstanding shares of Class A and Class B common stock, voting together as a single class.

##### ***Committees of our Board of Directors***

###### *Audit Committee*

Our board of directors has established an audit committee (the "Audit Committee"), which will have the composition and responsibilities described below, as of the effectiveness of the registration statement of which this prospectus forms a part. We believe that the composition of the Audit Committee meets the applicable independence requirements of the Nasdaq Listing Rules and Exchange Act rules, which permit us to phase in our compliance with such requirements as follows: (1) one independent member on the effective date of the registration statement of which this prospectus forms a part, (2) a majority of independent members within 90 days of the effective date of the registration statement of which this prospectus forms a part and (3) all independent members within one year of the effective date of the registration statement of which this prospectus forms a part.

Following the consummation of this offering, our Audit Committee will consist of Kirk B. Griswold, Brian F. Hughes and Janet B. Haugen, each of whom satisfies the independence requirements of the applicable Nasdaq Listing Rules and Exchange Act rules, and Barry J. Bentley. Brian F. Hughes will be the chair of our Audit Committee, and each of Kirk B. Griswold, Brian F. Hughes, Janet B. Haugen and Barry J. Bentley is an "audit committee financial expert," as defined in Item 407(d)(5) of Regulation S-K, and possesses financial sophistication as required by the Nasdaq Listing Rules. This designation does not impose any duties, obligations or liabilities that are greater than those that are generally imposed on members of our Audit Committee and our board of directors. Members serve on this committee until their resignations or until otherwise determined by our board of directors. Barry J. Bentley is expected to resign from the

Audit Committee within one year of the effectiveness of the registration statement of which this prospectus forms a part in accordance with the applicable Nasdaq Listing Rules and Exchange Act rules.

The Audit Committee will be responsible for, among other things:

- selection, retention, termination, compensation, and oversight of the work of an independent public accounting firm to act as our independent auditors, as well as any other public accounting firm engaged to prepare or issue an audit report or other audit, review or attest services;
- considering and approving, in advance, all audit and permitted non-audit and tax services to be performed by our independent auditors;
- reviewing and discussing the adequacy and effectiveness of our financial reporting processes, internal control over financial reporting and disclosure controls and procedures and the audits of our financial statements;
- establishing procedures for the receipt, retention, and treatment of complaints received by us regarding accounting, internal accounting controls or auditing matters and the confidential, anonymous submission by our colleagues of concerns regarding questionable accounting or auditing matters;
- investigating any matter brought to its attention within the scope of its duties and engaging independent counsel and other advisers as the Audit Committee deems necessary;
- determining compensation of advisors hired by the Audit Committee;
- reviewing quarterly financial statements prior to their release;
- reviewing and assessing the adequacy of a formal written charter on an annual basis;
- reviewing and approving related-party transactions for potential conflict of interest situations on an ongoing basis;
- managing risks to the Company by monitoring, discussing, reviewing, or developing policies and procedures with respect to risk exposures, compliance with applicable laws and the Company's policies and complaints regarding accounting or auditing matters; and
- handling such other matters that are specifically delegated to the Audit Committee by our board of directors from time to time.

Our board of directors adopted a written charter for our Audit Committee, which became available on our website upon effectiveness of the registration statement of which this prospectus forms a part. Such written charter for the Audit Committee will satisfy the applicable rules of the SEC and the listing standards of Nasdaq.

#### **Code of Conduct**

We are committed to ethical business conduct and have a code of conduct applicable to the conduct of our business by all of our colleagues, officers, and directors. Upon the effectiveness of the registration statement of which this prospectus forms a part, our code of conduct was posted on our website, [www.bentley.com](http://www.bentley.com). We intend to disclose future amendments to certain provisions of this code of conduct, or waivers of such provisions, applicable to any principal executive officer, principal financial officer, principal accounting officer or controller, or persons performing similar functions, and our directors, on our website. Information contained on our website is not a part of this prospectus and the inclusion of our website address in this prospectus is an inactive textual reference only.

## EXECUTIVE AND DIRECTOR COMPENSATION

This section discusses the material components of the executive compensation program for our executive officers who are named in the “Summary Compensation Table” below, whom we refer to as our “named executive officers.”

For the year ended December 31, 2019, or fiscal year 2019, our named executive officers and their positions were as follows:

- Gregory S. Bentley, Chairman, Chief Executive Officer and President;
- Keith A. Bentley, Chief Technology Officer and Director; and
- David J. Hollister, Chief Financial Officer and Chief Operations Advancement Officer.

This discussion may contain forward-looking statements that are based on our current plans, considerations, expectations, and determinations regarding future compensation programs. Actual compensation programs that we adopt in connection with or following the effectiveness of the registration statement of which this prospectus forms a part may differ materially from the currently planned programs summarized in this discussion.

### Summary Compensation Table

The following table presents information regarding the total compensation that was awarded to, earned by, or paid to our named executive officers for services rendered during fiscal year 2019.

Name and Principal Position	Year	Salary (\$) <sup>(1)</sup>	Bonus (\$)	Non-equity Incentive Plan Compensation (\$) <sup>(3)</sup>	All Other Compensation (\$) <sup>(4)</sup>	Total (\$)
Gregory S. Bentley <i>Chairman, Chief Executive Officer and President</i>	2019	200,000	—	12,130,273	23,842	12,354,115
Keith A. Bentley <i>Chief Technology Officer and Director</i>	2019	200,000	—	7,077,226	21,972	7,299,198
David J. Hollister <i>Chief Financial Officer and Chief Operations Advancement Officer</i>	2019	200,000	1,000 <sup>(2)</sup>	4,045,398	46,180	4,292,578

- (1) Amounts reflect the actual base salary earned by each named executive officer in fiscal year 2019.
- (2) Amount reflects a one-time discretionary bonus paid to Mr. Hollister in fiscal 2019 in recognition of his contributions to us in fiscal year 2019.
- (3) Amounts reflect the sum of the amount of \$12,127,313, \$7,074,266, and \$4,042,438 paid pursuant to the Bentley Systems, Incorporated Bonus Pool Plan to Gregory S. Bentley, Keith A. Bentley, and David J. Hollister, respectively, and an additional \$2,960 paid to each of these named executive officers pursuant to our global profit sharing plan, in each case with respect to fiscal year 2019. Please see the sections titled “2019 Bonuses — Bonus Pool Plan” and “2019 Bonuses — Global Profit Sharing Plan” below for further information.
- (4) Amounts reflect: (i) for Gregory S. Bentley, a \$15,000 per year vehicle allowance, a reimbursement of \$8,618 in connection with accompanying spousal/dependent children travel, and \$224 in company matching contributions to his account under our 401(k) plan; (ii) for Keith A. Bentley, a \$15,000 per year vehicle allowance, a reimbursement of \$6,748 in connection with accompanying spousal/dependent children travel, and \$224 in company matching contributions to his account under our 401(k) plan; and (iii) for David J. Hollister, a \$15,000 per year vehicle allowance, a \$12,500 health and fitness club

allowance, a reimbursement of \$15,456 in connection with accompanying spousal/dependent children travel, \$3,000 as a matching contribution to charity, and \$224 in company matching contributions under our 401(k) plan.

### **Narrative Disclosures to Summary Compensation Table**

The primary elements of compensation for our named executive officers are base salary, cash performance bonuses, and certain deferred compensation and retirement plans. These elements (and the amounts of compensation and benefits under each element) were selected because we believe they are necessary to help us attract and retain executive talent, which is fundamental to our success. Below is a more detailed summary of the current executive compensation program as it relates to our named executive officers.

#### ***Annual Base Salary***

The base salary payable to each named executive officer is intended to provide a fixed baseline component of compensation, which is supplemented by the significant variable-based component of their annual compensation, as described below.

As such, each of our named executive officers received a base salary of \$200,000 in fiscal year 2019.

#### ***2019 Bonuses***

##### ***Bonus Pool Plan***

Our key employees, including our named executive officers, participate in the Bentley Systems, Incorporated Bonus Pool Plan, as amended and restated, effective as of September 3, 2020 (the “Bonus Plan”). Pursuant to the Bonus Plan, participants are eligible to receive incentive bonuses that are determined based on our Management Report Operating Income, or adjusted operating income, as determined by our internal management accounts (“MROI”). For purposes of the Bonus Plan, the bonus pool thereunder may be funded with up to an aggregate of 20% of our adjusted MROI (as adjusted for accounting anomalies and other items identified as non-GAAP charges), subject to approval by our board of directors, which payments are made to plan participants based on each such participant’s allocated interest in the bonus pool.

A participant may defer any portion, or all, of such participant’s incentive bonus payable pursuant to the Bonus Plan into the DCP (as defined herein). Prior to September 3, 2020, a participant’s non-deferred incentive bonus was payable in cash. On September 3, 2020, we amended and restated the Bonus Plan to provide a participant with the ability to elect to receive any portion, or all, of such participant’s non-deferred incentive bonus in shares of fully vested Class B common stock, issued under our 2020 Incentive Award Plan. Such election must be made prior to the start of the applicable calendar quarter for which the incentive bonus is to be paid, and the number of shares of Class B common stock payable in respect of such elected amount is calculated using a volume-weighted average price of our Class B common stock for the period commencing on the tenth trading day prior to the end of the applicable calendar quarter and ending on the tenth trading day following the end of the applicable calendar quarter. Notwithstanding participants’ elections to receive shares of fully vested Class B common stock in respect of their non-deferred incentive bonus payments, if, in any calendar quarter, the aggregate dollar value of shares of fully vested Class B common stock payable in respect of the non-deferred incentive bonuses exceeds \$7.5 million, the portion of each participant’s non-deferred incentive bonus payable in shares of fully vested Class B common stock will be reduced pro rata such that the \$7.5 million limit is not exceeded, and, for each affected participant, the amount of such reduction will be payable in cash. With respect to fiscal year 2019, our named executive officers were allocated percentage interests in the Bonus Plan bonus pool as follows: a 36.4% (12/33) interest for Gregory S. Bentley, a 21.2% (7/33) interest for Keith A. Bentley, and a 12.1% (4/33) interest for David J. Hollister, and they were paid bonuses quarterly in the aggregate amounts of \$12,127,313, \$7,074,266, and \$4,042,438, respectively under the Bonus Plan.

##### ***Global Profit Sharing Plan***

Our full-time colleagues, including our named executive officers, are generally eligible to participate in our global profit sharing plan (the “Profit Sharing Plan”). Under the Profit Sharing Plan, each participant

is eligible for a cash bonus based upon the company's achievement of certain performance targets, which in fiscal year 2019 included the MROI. The target level of the MROI objective is based on our annual growth objectives and is set by members of our senior management at the beginning of the fiscal year. Under the Profit Sharing Plan, each participant receives an on-target bonus amount equal to 2% of such participant's eligible compensation with respect to fiscal year 2019, with payouts ranging from 0% (if threshold achievement of 75% of the applicable performance target is not achieved) to 6% of eligible compensation (if maximum achievement of the applicable performance target is achieved). Such amounts were determined on a straight-line basis between threshold and target, and target and maximum achievement levels. Such bonus amounts are then adjusted (which may be negative or positive) using a weighted multiplier based on our achievement of non-financial company performance objectives, as established by our senior management at the beginning of the fiscal year. For fiscal year 2019, each of the named executive officers were paid a cash bonus of \$2,960 in February 2020 under the Profit Sharing Plan.

#### *Hollister Bonus*

In addition to bonuses payable under the Bonus Plan and the Profit Sharing Plan, David J. Hollister was paid a one-time discretionary cash bonus of \$1,000 in recognition of his contributions to us in fiscal year 2019.

#### *Equity Compensation*

The 2015 Plan (as defined in the section below titled “— Equity Incentive Plans”) provides our officers, key employees, consultants, and directors the opportunity to participate in the equity appreciation of our business through the receipt of equity awards with respect to shares of our Class B common stock. No equity awards were granted to the named executive officers in fiscal year 2019. David J. Hollister, however, was previously granted an option to purchase 200,000 shares of our Class B common stock on May 27, 2015 under the 2015 Plan at an exercise price of \$3.495 per share. Such option is fully vested, with 100,606 shares subject to the option that remain outstanding and exercisable as of December 31, 2019.

On July 10, 2020, our board of directors approved the grant of 994,912 total shares of restricted stock and restricted stock units under the 2015 Plan to substantially all of our full-time colleagues, including 680 shares to each named executive officer, that vest upon the earlier of December 31, 2020 or the consummation of this offering.

#### *Other Benefits and Perquisites*

We offer participation in broad-based retirement, health, and welfare plans to all of our colleagues, including our named executive officers. We provide a 401(k) plan to our employees, including our current named executive officers, as discussed in the section below titled “— Profit Sharing/401(k) Plan.”

#### *Profit Sharing/401(k) Plan*

We sponsor a defined contribution plan intended to qualify for favorable tax treatment under Section 401(a) of the U.S. Internal Revenue Code of 1986, as amended (the “Code”), containing a cash or deferred feature that is intended to meet the requirements of Section 401(k) of the Code. The plan provides for employer matching or non-elective contributions on behalf of participants. Employer matching and non-elective contributions become 25% vested after one year of service and continue vesting thereafter at 25% per year until they are 100% vested following four years of service. Up to 100% of non-elective contributions may be invested in shares of our Class B common stock. For fiscal year 2019, each of our named executive officers received employer matching contributions of \$224 and no elective contributions.

#### *Nonqualified Deferred Compensation*

We sponsor the Bentley Systems, Incorporated Nonqualified Deferred Compensation Plan (the “DCP”). Under the DCP, key management colleagues, including our named executive officers, may defer all or any part of their incentive compensation and the company may make discretionary awards on behalf of such participants. Additionally, non-employee directors may defer all or any part of their directors' fees under our Nonqualified Deferred Compensation Plan for Non-Employee Directors. We have historically credited

participants with non-elective contributions to the DCP, but no such contributions have occurred since 2015. All deferrals are deemed invested in phantom shares of our Class B common stock and all benefits are distributed in actual shares of our Class B common stock.

For fiscal year 2019, Gregory S. Bentley and Keith A. Bentley elected to defer 10% and 20%, respectively, of their 2019 incentive compensation into the DCP. David J. Hollister did not defer any portion of his fiscal year 2019 incentive compensation. The following table shows the number of outstanding phantom shares of our Class B common stock held by each named executive officer as of December 31, 2019 under the DCP, including additional phantom shares acquired as a result of dividend equivalents credited on those phantom shares:

Name	Outstanding Phantom Shares
Gregory S. Bentley	3,240,932
Keith A. Bentley	2,917,970
David J. Hollister	3,542,184

#### *Employee Benefits and Perquisites*

All of our full-time colleagues, including our named executive officers, are eligible to participate in a standard suite of health and welfare benefit plans. In addition, we generally provide the following benefits to our senior executives, including our named executive officers:

- Reimbursement for health and fitness memberships and programs in an amount of up to \$12,500 per year;
- Reimbursement of certain costs of the executive's spouse and dependent children to accompany the executive on qualifying business trips in an amount of up to \$25,000 per year;
- An annual vehicle allowance of \$15,000; and
- Charitable matching contributions in an amount of up to \$12,500 per year.

We believe the benefits and perquisites described above are necessary and appropriate to provide a competitive compensation package to our senior executives, including our named executive officers.

#### *No tax gross-ups*

No named executive officers received any tax gross-ups in respect of compensation received by them in fiscal year 2019, nor are any named executive officers currently entitled to receive any such tax gross-ups in the future.



### Outstanding Equity Awards at Fiscal Year-End

The following table summarizes the number of shares of Class B common stock that were underlying outstanding equity incentive plan awards for each named executive officer for fiscal year 2019.

Name	Grant Date	Option Awards			
		Number of Securities Underlying Unexercised Options (#) Exercisable	Number of Securities Underlying Unexercised Options (#) Unexercisable	Option Exercise Price (\$)	Option Expiration Date
Gregory S. Bentley	—	—	—	—	—
Keith A. Bentley	—	—	—	—	—
David J. Hollister	05/27/2015	100,606 <sup>(1)</sup>	—	\$3.495	05/26/2020

- (1) The shares subject to the option vested ratably on each of the first four anniversaries of the grant date, subject to David J. Hollister's continued service with us through the applicable vesting dates. As of December 31, 2019, such shares are fully vested and exercisable.

### Employment Agreements

We do not have employment agreements with any of our named executive officers. However, each of our executive officers, including the named executive officers, has executed customary intellectual property assignment agreements for our benefit. Pursuant to those agreements, each of our executive officers has confirmed his or her understanding and agreement that any and all intellectual property and trade secrets (i) related to our business and (ii) contained in our products or systems that such executive has created, developed or otherwise produced or caused to be produced or delivered to us, or will so do in the future, is our property or will be assigned to us. Each executive has also agreed to take all further acts that may be necessary to transfer, perfect, and defend our ownership of such property.

### Equity Incentive Plans

#### 2015 Plan

We maintain the Bentley Systems, Incorporated 2015 Equity Incentive Plan, as amended and restated, effective as of May 29, 2018, and as further amended on July 10, 2020 (the "2015 Plan"). The 2015 Plan is intended to provide a means whereby we may attract and retain key employees, consultants, and directors and motivate them to exercise their best efforts on behalf of the company. The 2015 Plan provides for the grant of stock options, restricted stock, restricted stock units, stock appreciation rights, and dividend equivalent rights to our key employees, consultants, and non-employee directors and is administered by our board of directors. Under the 2015 Plan, 50,000,000 shares of Class B common stock are reserved for issuance. If an award granted under the 2015 Plan expires, terminates for any reason, is cancelled, or is forfeited, the shares subject to that award will be available for future grant under the 2015 Plan. In addition, if an option is exercised by surrendering shares as full or partial payment, or if tax withholding requirements are satisfied by surrendering shares to us or by withholding shares, only the number of shares issued net of shares withheld or surrendered shall be deemed delivered for purposes of determining the number of shares that remain available for grant under the 2015 Plan. The 2015 Plan provides that the per share exercise price of a nonqualified stock option granted thereunder cannot be less than the higher of 100% of the fair market value of a share of Class B common stock on the grant date, or the par value thereof. The 2015 Plan also provides that, on the day prior to the date on which any in-the-money option is scheduled to expire due to the expiration of the option term, that option will be automatically exercised using a net exercise method to cover both the exercise price and applicable tax withholding. The type and number of shares that may be issued under the 2015 Plan and the type and number of shares issuable under outstanding awards under the 2015 Plan, as well as the exercise price of outstanding options, will be adjusted to reflect any stock split, reverse stock split, stock dividend, distribution (including extraordinary cash dividends), spin-off, recapitalization, share combination or reclassification, or similar change in our capitalization.

In the event of a corporate transaction (such as a merger), the surviving or successor corporation is required to assume each outstanding award or substitute a new award for each outstanding award under the 2015 Plan unless our board of directors decides to terminate all or any portion of the outstanding awards effective upon the closing of the corporate transaction. If our board of directors decides to so terminate outstanding awards, each holder of outstanding options must receive at least seven days' notice of such termination and any option that is to be terminated will be exercisable (to the extent it is then exercisable) up to the time of termination. Upon the closing of such corporate transaction, such option, if not exercised, will be terminated, and we will pay to the holder thereof an amount equal to the difference between the fair market value of a share of Class B common stock (as of the date the option terminated) and the exercise price of the option. If the exercise price of such outstanding options equals or exceeds such fair market value, we will cancel the option without payment. Upon the occurrence of a change in control (as defined in the 2015 Plan), all outstanding unvested awards granted under the 2015 Plan will automatically vest; provided, however that unvested awards that were granted on or after July 10, 2020 will not automatically vest upon the occurrence of a change in control. Our board of directors may terminate the 2015 Plan at any time. Our board of directors has determined not to make additional awards under the 2015 Plan following the effectiveness of this prospectus. However, the 2015 Plan will continue to govern outstanding equity awards granted thereunder.

### ***2020 Incentive Award Plan***

On September 3, 2020, our board of directors adopted, and on September 14, 2020, our stockholders approved, the 2020 Omnibus Incentive Plan (the "2020 Incentive Award Plan"), subject to the consummation of this offering.

*Purpose.* The purpose of our 2020 Incentive Award Plan is to provide a means through which to attract and retain key personnel and to provide a means whereby our directors, officers, employees, consultants and advisors can acquire and maintain an equity interest in us, or be paid incentive compensation, including incentive compensation measured by reference to the value of our Class B common stock, thereby strengthening their commitment to our welfare and aligning their interests with those of our stockholders.

*Administration.* Our 2020 Incentive Award Plan will be administered by the compensation committee of our board of directors or such other committee of our board of directors to which it has properly delegated power, or if no such committee or subcommittee exists, our board of directors (the "Committee"). The Committee is authorized to interpret, administer, reconcile any inconsistency in, correct any defect in and/or supply any omission in our 2020 Incentive Award Plan and any instrument or agreement relating to, or any award granted under, our 2020 Incentive Award Plan; establish, amend, suspend, or waive any rules and regulations and appoint such agents as the Committee deems appropriate for the proper administration of our 2020 Incentive Award Plan; adopt sub-plans; and to make any other determination and take any other action that the Committee deems necessary or desirable for the administration of our 2020 Incentive Award Plan. Except to the extent prohibited by applicable law or the applicable rules and regulations of any securities exchange or inter-dealer quotation system on which our securities are listed or traded, the Committee may allocate all or any portion of its responsibilities and powers to any one or more of its members and may delegate all or any part of its responsibilities and powers to any person or persons selected by it in accordance with the terms of our 2020 Incentive Award Plan. Unless otherwise expressly provided in our 2020 Incentive Award Plan, all designations, determinations, interpretations, and other decisions under or with respect to our 2020 Incentive Award Plan or any award or any documents evidencing awards granted pursuant to our 2020 Incentive Award Plan are within the sole discretion of the Committee, may be made at any time and are final, conclusive and binding upon all persons or entities, including, without limitation, us, any participant, any holder or beneficiary of any award, and any of our stockholders. The Committee may make grants of awards to eligible persons pursuant to terms and conditions set forth in the applicable award agreement, as determined by the Committee in its sole discretion, to the extent not inconsistent with the terms of our 2020 Incentive Award Plan, including subjecting such awards to performance criteria listed in our 2020 Incentive Award Plan.

*Awards Subject to our 2020 Incentive Award Plan.* Our 2020 Incentive Award Plan provides that the total number of shares of Class B common stock that may be issued under our 2020 Incentive Award Plan

is 25,000,000 (the “Absolute Share Limit”); provided, however, that the the Absolute Share Limit is automatically increased on the first day of each fiscal year in an amount equal to the lower of 1% of the total number of shares of Class B common stock outstanding on the last day of the immediately preceding fiscal year and a lower number of shares of Class B common stock as determined by our board of directors. No more than 25,000,000 shares of Class B common stock may be issued in the aggregate pursuant to the exercise of incentive stock options. The maximum number of shares of Class B common stock granted during a single fiscal year to any non-employee director, taken together with any cash fees paid to such non-employee director during the fiscal year, may not exceed \$1,000,000 in total value (calculating the value of any such awards based on the grant date fair value of such awards for financial reporting purposes) or such lower amount as determined by our board of directors prior to the date of grant, either as part of our non-employee director compensation program or as otherwise determined by the board of directors in the event of any change to such non-employee director’s compensation program or for any particular period of service. Except for substitute awards (as described below), in the event any award expires or is cancelled, forfeited, terminated, settled in cash or otherwise settled without issuance to the participant of the full number of shares to which the award related, the unissued shares of Class B common stock may be granted again under our 2020 Incentive Award Plan. Shares of Class B common stock surrendered or withheld in payment of the exercise price, or taxes relating to an award, will be deemed to constitute shares not issued to a participant and shall again be available for awards under the plan, provided, that such shares shall not become available for issuance hereunder if either the applicable shares are withheld or surrendered following the termination of the plan or at the time the applicable shares are withheld or surrendered, it would constitute a material revision of the plan subject to stockholder approval under any then-applicable rules of any national securities exchange or inter-dealer quotation system on which the Class B common stock is listed or traded.

Awards may, in the sole discretion of the Committee, be granted in assumption of, or in substitution for, outstanding awards previously granted by an entity directly or indirectly acquired by us or with which we combine (referred to as “substitute awards”), and such substitute awards will not be counted against the Absolute Share Limit, except that substitute awards intended to qualify as “incentive stock options” will count against the limit on incentive stock options described above. No award may be granted under our 2020 Incentive Award Plan after the tenth anniversary of the effective date (as defined therein), but awards granted before then may extend beyond that date.

*Options.* The Committee may grant non-qualified stock options and incentive stock options, under our 2020 Incentive Award Plan, with terms and conditions determined by the Committee that are not inconsistent with our 2020 Incentive Award Plan. All stock options granted under our 2020 Incentive Award Plan are required to have a per share exercise price that is not less than 100% of the fair market value of our Class B common stock underlying such stock options on the date such stock options are granted (other than in the case of options that are substitute awards). All stock options that are intended to qualify as incentive stock options must be granted pursuant to an award agreement expressly stating that the options are intended to qualify as incentive stock options and will be subject to the terms and conditions that comply with the rules as may be prescribed by Section 422 of the Code. The maximum term for stock options granted under our 2020 Incentive Award Plan will be ten years from the initial date of grant, or with respect to any stock options intended to qualify as incentive stock options, such shorter period as prescribed by Section 422 of the Code. However, if a non-qualified stock option would expire at a time when trading of shares of our Class B common stock is prohibited by our insider trading policy (or “blackout period” imposed by us), the term will automatically be extended to the 30th day following the end of such period. The purchase price for the shares as to which a stock option is exercised may be paid to us, to the extent permitted by law, (1) in cash or its equivalent at the time the stock option is exercised; (2) in shares having a fair market value equal to the aggregate exercise price for the shares being purchased and satisfying any requirements that may be imposed by the Committee (so long as such shares have been held by the participant for at least six months or such other period established by the Committee to avoid adverse accounting treatment); or (3) by such other method as the Committee may permit in its sole discretion, including, without limitation, (A) in other property having a fair market value on the date of exercise equal to the purchase price, (B) if there is a public market for the shares at such time, through the delivery of irrevocable instructions to a broker to sell the shares being acquired upon the exercise of the stock option and to deliver to us the amount of the proceeds of such sale equal to the aggregate exercise price for the shares being purchased or (C) through a “net exercise” procedure effected by withholding the minimum number of shares needed to pay

the exercise price. Any fractional shares of Class B common stock will be settled in cash. If an exercisable option is scheduled to expire and the exercise price per share of Class B common stock of such option is less than the then-current fair market value of a share of Class B common stock, then on the date immediately preceding the date on which the option will expire, the option will be automatically exercised on behalf of the participant through a “net exercise” procedure.

*Stock Appreciation Rights.* The Committee may grant stock appreciation rights under our 2020 Incentive Award Plan, with terms and conditions determined by the Committee that are not inconsistent with our 2020 Incentive Award Plan. The Committee may award stock appreciation rights in tandem with options or independent of any option. Generally, each stock appreciation right will entitle the participant upon exercise to an amount (in cash, shares or a combination of cash and shares, as determined by the Committee) equal to the product of (1) the excess of (A) the fair market value on the exercise date of one share of Class B common stock, over (B) the strike price per share, times (2) the number of shares of Class B common stock covered by the stock appreciation right. The strike price per share of a stock appreciation right will be determined by the Committee at the time of grant but in no event may such amount be less than 100% of the fair market value of a share of Class B common stock on the date the stock appreciation right is granted (other than in the case of stock appreciation rights granted in substitution of previously granted awards). The maximum term for stock appreciation rights under our 2020 Incentive Award Plan will be ten years from the initial date of grant. However, if a stock appreciation right would expire at a time when trading of shares of our Class B common stock is prohibited by our insider trading policy (or “blackout period” imposed by us), the term will automatically be extended to the 30th day following the end of such period. If an exercisable stock appreciation right is scheduled to expire and the exercise price per share of Class B Common Stock of such stock appreciation right is less than the then-current fair market value of a share of Class B Common Stock, then on the date immediately preceding the date on which the option will expire, the stock appreciation right will be automatically exercised on behalf of the participant through a “net exercise” procedure.

*Restricted Shares and Restricted Stock Units.* The Committee may grant restricted shares of our Class B common stock or restricted stock units, representing the right to receive, upon vesting and the expiration of any applicable restricted period, one share of Class B common stock for each restricted stock unit, or, in the sole discretion of the Committee, the cash value thereof (or any combination thereof). As to restricted shares of our Class B common stock, subject to the other provisions of our 2020 Incentive Award Plan, the holder will generally have the rights and privileges of a stockholder as to such restricted shares of Class B common stock, including, without limitation, the right to vote such restricted shares of Class B common stock. Participants have no rights or privileges as a stockholder with respect to restricted stock units.

*Other Equity-Based Awards and Cash-Based Awards.* The Committee may grant other equity-based or cash-based awards under our 2020 Incentive Award Plan, with terms and conditions determined by the Committee that are not inconsistent with our 2020 Incentive Award Plan.

*Effect of Certain Events on the 2020 Incentive Award Plan and Awards.* In the event of (1) any dividend (other than regular cash dividends) or other distribution (whether in the form of cash, shares of Class B common stock, other securities or other property), recapitalization, stock split, reverse stock split, reorganization, merger, consolidation, split-up, split-off, spin-off, combination, repurchase or exchange of shares of Class B common stock or other securities, issuance of warrants or other rights to acquire shares of Class B common stock or other securities, or other similar corporate transaction or event that affects the shares of Class B common stock (including a change in control, as defined in our 2020 Incentive Award Plan), or (2) unusual or nonrecurring events affecting the Company, including changes in applicable rules, rulings, regulations or other requirements, that the Committee determines, in its sole discretion, could result in substantial dilution or enlargement of the rights intended to be granted to, or available for, participants (any event in (1) or (2), an “Adjustment Event”), the Committee will, in respect of any such Adjustment Event, make such proportionate substitution or adjustment, if any, as it deems equitable, to any or all of: (A) the Absolute Share Limit, or any other limit applicable under our 2020 Incentive Award Plan with respect to the number of awards which may be granted thereunder, (B) the number of shares of Class B common stock or other securities of the Company (or number and kind of other securities or other property) which may be issued in respect of awards or with respect to which awards may be granted under our 2020 Incentive

Award Plan or any sub-plan and (C) the terms of any outstanding award, including, without limitation, (1) the number of shares of Class B common stock or other securities of the Company (or number and kind of other securities or other property) subject to outstanding awards or to which outstanding awards relate, (2) the exercise price or strike price with respect to any award, or (3) any applicable performance measures; it being understood that, in the case of any “equity restructuring,” the Committee will make an equitable or proportionate adjustment to outstanding awards to reflect such equity restructuring.

In connection with any change in control, the Committee may, in its sole discretion, provide for any one or more of the following: (1) a substitution or assumption of awards, or to the extent the surviving entity does not substitute or assume the awards, the acceleration of vesting of, the exercisability of, or lapse of restrictions on awards immediately prior to, and contingent upon, the consummation of such Change in Control and (2) subject to any limitations or reductions as may be necessary to comply with Section 409A of the Code, cancellation of any one or more outstanding awards and payment to the holders of such awards that are vested as of such cancellation (including any awards that would vest as a result of the occurrence of such event but for such cancellation) the value of such awards, if any, as determined by the Committee (which value, if applicable, may be based upon the price per share of Class B common stock received or to be received by other holders of our Class B common stock in such event), including, in the case of stock options and stock appreciation rights, a cash payment equal to the excess, if any, of the fair market value of the shares of Class B common stock subject to the option or stock appreciation right over the aggregate exercise price or strike price thereof.

*Nontransferability of Awards.* Each award will not be transferable or assignable by a participant other than by will or by the laws of descent and distribution and any such purported assignment, alienation, pledge, attachment, sale, transfer or encumbrance will be void and unenforceable against us or any of our subsidiaries.

However, the Committee may, in its sole discretion, permit awards (other than incentive stock options) to be transferred, including transfers to a participant’s family members, any trust established solely for the benefit of a participant or such participant’s family members, any partnership or limited liability company of which a participant, or such participant and such participant’s family members, are the sole member(s), and a beneficiary to whom donations are eligible to be treated as “charitable contributions” for tax purposes.

*Amendment and Termination.* Our board of directors may amend, alter, suspend, discontinue, or terminate our 2020 Incentive Award Plan or any portion thereof at any time; but no such amendment, alteration, suspension, discontinuance or termination may be made without stockholder approval if (1) such approval is necessary to comply with any regulatory requirement applicable to our 2020 Incentive Award Plan or for changes in U.S. GAAP to new accounting standards; (2) it would materially increase the number of securities which may be issued under our 2020 Incentive Award Plan (except for adjustments in connection with certain corporate events); or (3) it would materially modify the requirements for participation in our 2020 Incentive Award Plan; and any such amendment, alteration, suspension, discontinuance or termination that would materially and adversely affect the rights of any participant or any holder or beneficiary of any award will not to that extent be effective without such individual’s consent.

The Committee may, to the extent consistent with the terms of any applicable award agreement, waive any conditions or rights under, amend any terms of, or alter, suspend, discontinue, cancel or terminate, any award granted or the associated award agreement, prospectively or retroactively (including after a participant’s termination). However, except as otherwise permitted in our 2020 Incentive Award Plan, any such waiver, amendment, alteration, suspension, discontinuance, cancellation or termination that would materially and adversely affect the rights of any participant with respect to such award will not to that extent be effective without such individual’s consent. In addition, without stockholder approval, except as otherwise permitted in our 2020 Incentive Award Plan, (1) no amendment or modification may reduce the exercise price of any option or the strike price of any stock appreciation right; (2) the Committee may not cancel any outstanding option or stock appreciation right and replace it with a new option or stock appreciation right (with a lower exercise price or strike price, as the case may be) or other award or cash payment that is greater than the value of the cancelled option or stock appreciation right; and (3) the Committee may not take any other action which is considered a “repricing” for purposes of the stockholder approval rules of any securities exchange or inter-dealer quotation system on which our securities are listed or quoted.

*Dividends and Dividend Equivalents.* The Committee in its sole discretion may provide part of an award with dividends or dividend equivalents, on such terms and conditions as may be determined by the Committee in its sole discretion. Unless otherwise provided in the award agreement, any dividend payable in respect of any share of restricted stock that remains subject to vesting conditions at the time of payment of such dividend will be retained by the Company and remain subject to the same vesting conditions as the share of restricted stock to which the dividend relates.

*Data Protection.* By participating in the plan or accepting any rights granted under it, each participant consents to the collection and processing of personal data so that we and our affiliates can fulfill our obligations and exercise our rights under our 2020 Incentive Award Plan and generally administer and manage our 2020 Incentive Award Plan. This data will include, but may not be limited to, data about the participant's participation in our 2020 Incentive Award Plan and shares offered or received, purchased, or sold under our 2020 Incentive Award Plan from time to time and other appropriate financial and other data (such as the date on which the awards were granted under our 2020 Incentive Award Plan).

*Clawback/Repayment.* All awards are subject to reduction, cancellation, forfeiture or recoupment to the extent necessary to comply with (i) any clawback, forfeiture or other similar policy adopted by our board of directors or the Committee and as in effect from time to time and (ii) applicable law. To the extent that a participant receives any amount in excess of the amount that the participant should otherwise have received under the terms of the award for any reason (including, without limitation, by reason of a financial restatement, mistake in calculations or other administrative error), the participant will be required to repay any such excess amount to the Company.

*Detrimental Activity.* If a participant has engaged in any detrimental activity, as defined in our 2020 Incentive Award Plan, as determined by the Committee, the Committee may, in its sole discretion, provide for one or more of the following: (i) cancellation of any or all of such participant's outstanding awards or (ii) forfeiture by the participant of any gain realized on the vesting or exercise of awards, and prompt repayment of any such gain to us.

### ***Global Employee Stock Purchase Plan***

On September 3, 2020, our board of directors adopted, and on September 14, 2020, our stockholders approved, our Global Employee Stock Purchase Plan (the "Global ESPP") to become effective on the date immediately preceding, and contingent upon, our initial public offering, and to remain effective until terminated by our board of directors. The purpose of the Global ESPP is to provide an opportunity for eligible employees of the Company and any parent, subsidiary or affiliate of the Company that has been designated by our board of directors or any properly delegated committee or subcommittee thereof (the "committee") to purchase shares of our Class B common stock at a discount through voluntary payroll deductions from such employees' eligible compensation. The purchase rights granted under the Global ESPP are intended to be treated as either (i) purchase rights granted under an "employee stock purchase plan," as that term is defined in Section 423 of the Code (a "Section 423 Offering"), or (ii) purchase rights granted under an employee stock purchase plan that is not subject to the requirements of Section 423 of the Code (a "Non-Section 423 Offering"). The following summary of the Global ESPP is qualified in its entirety by reference to the Global ESPP that is ultimately adopted by our board of directors.

*Administration.* The Global ESPP will be administered by the committee. The committee will have, among other authority, the authority to interpret the Global ESPP, determine eligibility and adjudicate disputed claims under the Global ESPP, determine the terms and conditions of purchase rights under the Global ESPP, and to make any other determination and take any other action desirable for the administration of the Global ESPP. To the extent not prohibited by applicable laws, the committee may delegate its authority to a subcommittee, to one or more officers of the Company or to other persons or groups of persons, including to assist with the day-to-day administration of the Global ESPP.

*Eligibility.* Generally, any individual in an employee-employer relationship with the Company or a participating company for income tax and employment tax withholding and reporting purposes is eligible to participate in the Global ESPP and may participate by submitting an enrollment agreement or appropriate online form to the Company under procedures specified by the committee. The committee, in its discretion, may determine on a uniform basis for an offering that employees will not be eligible to participate if the

employee has not met certain conditions prescribed in the Global ESPP. No employee is eligible for the grant of any purchase rights under the Global ESPP if, immediately after such grant, the employee would own shares of our Class B common stock possessing 5% or more of the total combined voting power or value of all classes of shares of common stock of the Company or of any subsidiary or parent of the Company (including any shares of Class B common stock which such employee may purchase under all outstanding purchase rights), nor will any employee be granted purchase rights to buy more than \$25,000 worth of shares of Class B common stock (determined based on the fair market value of the shares of Class B common stock on the date the purchase rights are granted) under the Global ESPP in any calendar year such purchase rights are outstanding. Eligible employees who are citizens or resident of a jurisdiction outside the United States may be excluded from participation in the Global ESPP if their participation is prohibited under local laws or if complying with local laws would cause a Section 423 Offering to fail to qualify under Section 423 of the Code. In the case of a Non-Section 423 Offering, eligible employees may be excluded from participation in the Global ESPP or an offering if the committee has determined that participation of such eligible employees is not advisable or practicable for any reason.

*Number of Shares Authorized.* The maximum number of shares of Class B common stock available for issuance under the Global ESPP will be no more than 25,000,000 shares of Class B common stock. The shares of Class B common stock may be authorized but unissued shares, treasury shares or shares purchased in the open market. In the event of any change affecting the number, class, value, or terms of the shares of Class B common stock resulting from a recapitalization, stock split, reverse stock split, stock dividend, spinoff, split up, combination, reclassification or exchange of shares of Class B common stock, merger, consolidation, rights offering, separation, reorganization or liquidation or any other change in the corporate structure or shares of Class B common stock, including any extraordinary dividend or extraordinary distribution (but excluding any regular cash dividend), then the committee, in order to prevent dilution or enlargement of the benefits or potential benefits intended to be made available under the Global ESPP, will, in such manner as it may deem equitable, adjust the number and class of shares of Class B common stock that may be delivered under the Global ESPP, the purchase price per share and the number of shares of Class B common stock covered by each right under the Global ESPP that has not yet been exercised.

*Non-U.S. Sub-Plans.* The committee will also have the authority to adopt such sub-plans as are necessary or appropriate to permit the participation in the Global ESPP by employees who are foreign nationals or employed outside the United States. Such sub-plans may vary the terms of the Global ESPP, other than with respect to the number of shares of Class B common stock reserved for issuance under the Global ESPP, to accommodate the requirements of local laws, customs and procedures for non-U.S. jurisdictions.

*Offering Periods.* The Global ESPP will be implemented by means of consecutive offering periods, with the first offering period commencing on the first trading day on or after January 1, 2021 and ending on the last trading day on or before June 30, 2021. Unless otherwise determined by the committee, offering periods will run from January 1st (or the first trading day thereafter) through June 30th (or the first trading day prior to such date), and from July 1st (or the first trading day thereafter) through December 31st (or the first trading day prior to such date). The committee has the authority to establish additional or alternative sequential or overlapping offering periods, a different number of purchase periods within an offering period, or a different duration for one or more offering periods or purchase periods or different commencement or ending dates for such offering periods with respect to future offerings, provided that no offering period may have a duration that exceeds 27 months.

*Contributions, Purchase Price and Purchase of Shares.* Except as otherwise provided by the committee, up to a maximum of 15% of an employee's "eligible compensation" (as defined in the Global ESPP) may be contributed by payroll deductions toward the purchase of shares of Class B common stock in each purchase period. An employee may elect to increase or decrease the rate of contributions during a subsequent enrollment period to the Global ESPP. The purchase price per share at which shares of Class B common stock are sold in an offering period under the Global ESPP will be equal to the lesser of 85% of the fair market value of a share of Class B common stock (i) on the first trading day of the offering period, or (ii) on the purchase date (*i.e.*, the last trading day of the purchase period). For this purpose, "fair market value" generally means the closing price of a share of Class B common stock on the applicable date.

Each purchase right automatically will be exercised on the applicable purchase date, and shares of Class B common stock will be purchased on behalf of each employee by applying the employee's contributions for the applicable purchase period to the purchase of whole shares of Class B common stock at the purchase price in effect for that purchase date. The maximum number of shares of Class B common stock purchasable per employee during any single offering period may not exceed 4,000 shares, or such other amount as may be designated by the committee.

*Withdrawals and Termination of Employment.* An employee may withdraw from participating in the Global ESPP in an offering period and receive a refund of his or her contributions by following the procedures prescribed by the committee. Upon receipt of a notice of withdrawal, deductions of contributions on behalf of the employee will be discontinued commencing with the payroll period immediately following the effective date of the notice of withdrawal, and such employee will be ineligible to participate in the Global ESPP until the next enrollment period. Amounts credited to the account of any employee who withdraws will be refunded, without interest, as soon as practicable. Upon termination of employment or other loss of eligible employee status for any reason, Global ESPP participation is immediately terminated, contributions will be discontinued and any amounts then credited to the employee's contribution account will be refunded, without interest, as soon as practicable.

*Change in Control.* In the event of a "Change in Control" (as defined in the Global ESPP but excluding a liquidation or dissolution of the Company), our board of directors or the committee may take any action it deems necessary with respect to the outstanding rights to purchase shares of Class B common stock, including but not limited to, accelerating the purchase date or discontinuing contributions and refunding any previously made contributions, without interest, as soon as practicable. Our board of directors or committee has the right to determine the treatment of outstanding purchase rights under the Global ESPP in the event of a liquidation or dissolution of the Company.

*Amendment and Termination of ESPP.* Our board of directors or the committee may amend the Global ESPP at any time, provided that if shareholder approval is required pursuant to the Code, securities laws or regulations, or the rules or regulations of the securities exchange on which the Company's shares of Class B common stock are listed or traded, then no such amendment will be effective unless approved by the Company's shareholders within such time period as may be required. Our board of directors may suspend the Global ESPP or discontinue the Global ESPP at any time, including shortening an offering period in connection with a spin-off or similar corporate event. Upon termination of the Global ESPP, all contributions will cease, all amounts credited to an employee's account will be equitably applied to the purchase of whole shares of Class B common stock then available for sale, and any remaining amounts will be promptly refunded, without interest, to the employees.

#### Director Compensation Table

The following table provides information regarding the total compensation that was earned by or paid to each of our non-employee directors for fiscal year 2019.

Name	Fees Earned or Paid in Cash (\$)	Stock Awards (\$) <sup>(2)</sup>	Option Awards (\$) <sup>(3)</sup>	Total (\$)
Kirk Griswold	15,000 <sup>(1)</sup>	53,358	16,500	84,858

- (1) Amount reflects an annual cash retainer of \$15,000 for Kirk Griswold's service as chair of the audit committee of our board of directors.
- (2) Kirk Griswold elected to receive shares of Class B common stock in lieu of a \$50,000 annual cash retainer, which he was entitled to in connection with his service on our board of directors. This amount reflects the grant-date fair value of such stock award computed in accordance with ASC Topic 718, rather than the amounts paid to or realized by Kirk Griswold. We provide information regarding the assumptions used to calculate the value of all stock awards made to our directors in Note 13 to our consolidated financial statements included elsewhere in this prospectus.
- (3) Amounts reflect the full grant-date fair value of stock options granted during fiscal year 2019 computed



in accordance with ASC Topic 718, rather than the amounts paid to or realized by Kirk Griswold. We provide information regarding the assumptions used to calculate the value of all option awards made to our directors in Note 13 to our consolidated financial statements included elsewhere in this prospectus.

Kirk Griswold was our only non-employee director in fiscal year 2019. The below reflects the aggregate number of outstanding equity awards held by Kirk Griswold as of December 31, 2019:

Name	Outstanding at Fiscal Year End <sup>(1)</sup>
Kirk Griswold	60,000

- (1) Kirk Griswold holds options to purchase 60,000 shares of our Class B common stock, 27,500 shares of which are vested and 32,500 shares of which are unvested.

Our employee directors for fiscal year 2019, Barry J. Bentley, Gregory S. Bentley, Keith A. Bentley, and Raymond B. Bentley, did not receive any additional compensation for their service on our board of directors and it continues to be the case in fiscal year 2020 that employee directors will not receive additional compensation for such service. See the section titled “Executive and Director Compensation” above for more information about Gregory S. Bentley and Keith A. Bentley’s compensation for fiscal year 2019.

Prior to our adoption of the Bentley Systems, Incorporated Non-Employee Director Compensation Policy described below, our non-employee directors were entitled to receive an annual cash retainer of \$50,000 (paid in equal quarterly installments) for service on our board of directors, as well as an additional cash retainer of \$15,000 for service on the audit committee of our board of directors. Prior to each applicable year, each such director could elect to receive shares of our Class B common stock with a fair market value of \$50,000 as of the commencement of such year (paid quarterly in equal installments) in lieu of the \$50,000 annual cash retainer. Each non-employee director was also entitled to receive an initial option award to purchase 25,000 shares of our Class B common stock upon his or her appointment to our board of directors and an annual option award to purchase 10,000 shares of our Class B common stock. All options granted to non-employee directors (including all options granted to Kirk Griswold described herein) vest ratably on each of the first four anniversaries of the grant date, subject to the director’s continued service with us through the applicable vesting dates.

Kirk Griswold was our only non-employee director in fiscal year 2019 and elected to receive shares of our Class B common stock in lieu of the annual cash retainer payable in fiscal year 2019. As a result, in fiscal year 2019 Kirk Griswold received a \$15,000 cash retainer for his service on the audit committee as well as an aggregate of 7,016 shares of our Class B common stock in four installments occurring on each original quarterly payment date for his annual cash retainer.

Further, on May 15, 2019, Kirk Griswold received an annual option grant to purchase 10,000 shares of Class B common stock at an exercise price per share of \$7.24. Additionally, Kirk Griswold previously received option grants in connection with his service on our board of directors of: an option for 20,000 shares of our Class B common stock, granted on May 11, 2016 at an exercise price per share of \$5.23; an option for 20,000 shares of our Class B common stock, granted on May 10, 2017 at an exercise price per share of \$5.38; and an option for 10,000 shares of our Class B common stock, granted on May 29, 2018 at an exercise price per share of \$6.805.

As discussed above in “— Other Benefits and Perquisites — Nonqualified Deferred Compensation,” our non-employee directors are eligible to participate in our Nonqualified Deferred Compensation Plan for Non-Employee Directors, which permits such directors to defer all or any part of their director compensation. Deferrals under our Nonqualified Deferred Compensation Plan for Non-Employee Directors will be paid out, as elected by the participating non-employee director, after the earliest to occur of (i) his or her separation from service (within the meaning of Code Section 409A), (ii) a date or dates chosen by the director, or (iii) a change in control that meets the requirements of Code Section 409A. As elected by the non-employee director, distributions will be made as a single distribution or in annual installments for a period of two to ten years. All deferrals are deemed invested in phantom shares of our Class B common stock, dividend equivalents are credited on such phantom shares and deemed reinvested as additional phantom

shares, and all benefits are distributed in actual shares of our Class B common stock. 500,000 shares of our Class B common stock are authorized for issuance under our Nonqualified Deferred Compensation Plan for Non-Employee Directors. Our board of directors may terminate or amend this plan at any time, but no termination or amendment can materially impair the rights of a participant without his or her consent. Kirk Griswold did not defer any compensation under such plan during fiscal year 2019.

On March 12, 2020, we adopted the Bentley Systems, Incorporated Independent Director Compensation Policy, which we amended and renamed the Bentley Systems, Incorporated Non-Employee Director Compensation Policy on September 3, 2020. The Bentley Systems, Incorporated Non-Employee Director Compensation Policy, which will be effective upon the consummation of this offering, will be implemented for directors elected or re-elected in 2020 and supersedes the director compensation policy described above. The new policy provides that all non-employee directors will be paid compensation for services provided to us as set forth below:

- \$50,000 payable upon the non-employee director's first election or appointment to our board of directors if upon election such director is an independent director under the rules and regulations of any exchange on which the Company's stock is listed;
- if such director has never been an employee of the Company or its subsidiaries, a fully vested award of \$100,000 worth of our Class B common stock (awarded pursuant to our 2015 Equity Incentive Plan, or any successor plan then in effect), granted upon the non-employee director's first election or appointment to our board of directors;
- if such director has never been an employee of the Company or its subsidiaries, a fully vested award of \$150,000 worth of our Class B common stock (awarded pursuant to our 2015 Equity Incentive Plan, or any successor plan then in effect), granted immediately following the non-employee director's re-election to our board of directors at our Annual Meeting of Stockholders;
- an annual retainer of \$50,000 for service on our board of directors;
- an annual retainer of \$50,000 for service on one or more committees of our board of directors; and
- an annual retainer of \$75,000 for service as the chairperson on one or more committees of our board of directors.

All cash retainers will be paid annually in advance, with 25% of each such retainer deemed to be compensation for each calendar quarter of service during the applicable calendar year. If a director resigns from our board of directors or is removed for cause, such director will be obligated to repay to us any cash retainer amounts attributable to calendar quarters for which services will not be rendered for a full calendar quarter during the applicable year (with no pro-rata credit for service during part of a quarter). A non-employee director who serves as a member of more than one board committee will only receive one annual committee member service retainer and a non-employee director who serves as the chairperson of more than one board committee will only receive one annual committee chairperson service retainer. A non-employee director who receives an annual retainer for service as a committee chairperson will not also receive an annual retainer for service as a member of a committee.

Except for the annual retainer for service as the chairperson of a board committee, each non-employee director who has never been an employee of the Company or its subsidiaries may elect to receive his or her annual cash retainer in the form of an award of restricted stock (awarded under our 2015 Equity Incentive Plan, or any successor plan then in effect), based on the fair market value of our Class B common stock on the applicable award date, which restricted stock award will be subject to vesting as to 25% of the award at the end of each calendar quarter during the applicable year of service.

## CERTAIN RELATIONSHIPS AND RELATED PARTY TRANSACTIONS

We have not been a party to any transactions since January 1, 2017 in which the amount involved exceeded \$120,000 and in which any of our executive officers, directors or beneficial holders of more than five percent of our capital stock had or will have a direct or indirect material interest, other than the arrangements described below or under the section titled “Executive and Director Compensation.”

### **Our Relationship with Siemens AG**

#### *Common Stock Purchase Agreement*

In September 2016, we and the Bentleys (other than Richard P. Bentley, who is not a party to the Common Stock Purchase Agreement) and certain of their family members and family trusts entered into a Common Stock Purchase Agreement with Siemens AG (“Siemens”), as amended, pursuant to which Siemens was authorized, and agreed, to acquire (prior to our IPO) up to \$100 million of our Class B common stock from our existing stockholders. Subsequent amendments increased this amount to \$250 million (the “Maximum Purchase Amount”). The Maximum Purchase Amount, upon the earlier of September 2021 or the Maximum Purchase Amount being reached, increases by \$20 million on each subsequent anniversary of the date of the Common Stock Purchase Agreement so long as the Strategic Collaboration Agreement (as defined below) remains in effect on each subsequent anniversary, with the next increase to the Maximum Purchase Amount set to occur on September 23, 2020. For the years ended December 31, 2017, 2018, and 2019, Siemens paid \$58.1 million, \$39.0 million, and \$5.7 million, respectively, for an aggregate of 16.4 million shares of our Class B common stock. As of December 31, 2019, Siemens beneficially owned, through one or more of its affiliates, 30,995,246 shares of our Class B common stock. On June 18, 2020, Siemens purchased an additional 4,574,399 Class B common shares from our existing stockholders for \$15.48 per share to reach the Maximum Purchase Amount of \$250 million. As of June 30, 2020, Siemens beneficially owned, through one or more of its affiliates, 35,569,645 shares of our Class B common stock.

In addition to the opportunity to acquire shares of our Class B common stock, the Common Stock Purchase Agreement also granted to Siemens: (i) certain information rights prior to the effectiveness of the registration statement of which this prospectus forms a part, including the right to receive our financial statements and information regarding our capital structure; and (ii) certain protective rights prior to the effectiveness of the registration statement of which this prospectus forms a part, including provisions that (A) limit our ability to amend, alter or repeal any provision of our certificate of incorporation and by-laws in a manner that disproportionately affects the powers, preferences or rights of our Class B common stock (other than, for the avoidance of doubt, any amendments, restatements or other modifications that by their terms are only effective upon the effectiveness of a registration statement in connection with an underwritten public offering of our common stock), and (B) limit the extent to which we could engage in repurchases of our common stock prior to Siemens’ cumulatively reaching the Maximum Purchase Amount. In addition, the Common Stock Purchase Agreement provides that upon the effectiveness of the registration statement of which this prospectus forms a part, (i) our Class B common stock will have voting rights and will be the class of securities offered to the public in such offering and (ii) our certificate of incorporation and any other related documentation shall be amended to reflect the voting rights, including voting ratios and sunset provisions agreed to in the Common Stock Purchase Agreement, and the Company shall not deviate from such voting structure in any manner adverse to Siemens in any material respect without Siemens’ prior written consent.

Subject to certain exceptions, we, along with the Bentley family members party to the Common Stock Purchase Agreement, also granted to Siemens a right of first refusal (and, as applicable, tag-along rights) on any fundamental sale transaction undertaken by the Company, as well as any new issuance of stock, and, subject to certain exceptions, sales of stock by the Bentley family members party thereto.

In connection with the effectiveness of the registration statement of which this prospectus forms a part, Siemens’ right of first refusal terminates (see “Prospectus Summary — Recent Developments — Relationship with Siemens”), but certain rights and restrictions set forth in the Common Stock Purchase Agreement continue to apply, including the following:

*Right of Participation.* Following the effectiveness of the registration statement of which this prospectus forms a part, we and the Bentley family members party to the Common Stock Purchase Agreement have agreed, as applicable, to notify Siemens of our intent to undertake any fundamental sale transaction, non-public offering of stock by us or sale by any Bentley family member party thereto of more than 1% of our fully-diluted capital stock, including any such transaction that may come about as a result of a non-public offer from a third party. Upon receipt of such notice, Siemens has twenty days to submit to the Company or the relevant Bentley family member, as applicable, a binding offer to engage in such transaction and to propose material transaction terms. Siemens may from time to time improve its proposed terms subject to our or the relevant seller's right to request "best and final" offers from Siemens and any other relevant third party. Neither we nor any member of the Bentley family party to the Common Stock Purchase Agreement is obligated to accept any offer submitted by Siemens, subject only to our agreement not to consummate any subject transaction with a third party on terms less favorable in the aggregate than those proposed by Siemens during the period beginning on the date Siemens proposes such offer and expiring twelve months thereafter or upon the expiration, withdrawal or revocation of Siemens' offer, whichever comes first.

*Rights in a Public Offering.* If this registration statement becomes effective after September 23, 2020, we are required to sell, and Siemens is required to purchase, at the initial public offering price, shares, which represents the number of additional shares necessary so that upon the consummation of this offering, Siemens shall have acquired (including pursuant to private sale transactions under the Common Stock Purchase Agreement prior to the effectiveness of the registration statement of which this prospectus forms a part) an aggregate of \$270 million worth of our Class B common stock. We currently anticipate consummating this offering prior to September 23, 2020.

If, following this offering, the Company issues shares of capital stock in a public offering, Siemens has the right to purchase, for the price per share used in such public offering, additional shares as are necessary so that Siemens' percentage ownership on a fully diluted basis at the time of such public offering, is unchanged as a result of such public offering.

*Lock-up.* Siemens has agreed in the Common Stock Purchase Agreement that, upon the effectiveness of the registration statement of which this prospectus forms a part, it will not sell, make any short sale of, loan or otherwise dispose of any shares of Class B common stock (other than any shares sold to the underwriters) for a period of 180 days from the date of effectiveness. The Common Stock Purchase Agreement also requires Siemens to execute and deliver to the underwriters a lock-up agreement reflecting the foregoing terms.

*Standstill Agreement.* Siemens has agreed that following the effectiveness of the registration statement of which this prospectus forms a part, it will not directly or indirectly acquire shares of our Class B common stock such that following such acquisition Siemens and its affiliates, and the Company's affiliates (each as determined under Rule 144) would beneficially own 80% or more of our issued and outstanding shares of capital stock.

*Disclaimer of Corporate Opportunity.* We have waived to the fullest extent permitted by applicable law any claim against Siemens based upon the corporate opportunity doctrine or otherwise that could limit Siemens' ability to pursue other opportunities, including acquisitions or investments, that may compete with or be complimentary to our business, and Siemens is under no obligation to offer any such opportunities to us.

#### **Registration Rights Agreement**

In connection with the Common Stock Purchase Agreement, we and an affiliate of Siemens entered into a registration rights agreement. Beginning eighteen months following the effectiveness of the registration statement of which this prospectus forms a part, Siemens may request one consummated registration by the Company of its shares on Form S-1 and unlimited registrations on Form S-3 (to the extent available, and no more than two per year). In addition, subject to certain exceptions, if we propose to register any of our securities under the Securities Act in connection with the public offering of such securities, upon the request of Siemens, we will register all of the capital stock that Siemens has requested to be included in such registration, subject to any proportionate cut back at the request of any underwriter used in connection

with such registration. In connection with any of these the registrations, we will indemnify Siemens and we will bear all fees, costs, and expenses (except underwriting commissions and discounts).

### ***Strategic Collaboration Agreement***

In conjunction with the Common Stock Purchase Agreement, we entered into a strategic collaboration agreement with Siemens. This agreement governs our collaboration with Siemens and certain of its divisions on the development, marketing, and distribution of agreed upon software and software development projects. The initial term of the agreement lasts until December 31, 2026 and automatically renews for successive one year terms unless either party elects to terminate the agreement by providing notice of termination at least one year prior to the expiration of the then current term. In addition, Siemens has the right to terminate the agreement and any related collaboration projects if the Bentleys no longer own a majority of our voting power or if we otherwise undergo a change of control.

### ***Licensing Transactions***

Siemens, through its various affiliates, has historically been and continues to be a user of our software, including pursuant to one or more SELECT Agreements.

We are also party to several royalty-bearing license agreements with certain Siemens affiliates pursuant to which each party has licensed technology from the other for use in its own software products. Certain of these arrangements generally pre-date Siemens' acquisition of our Class B common stock. In addition, under the framework of the strategic collaboration agreement referenced above, we are party to several agreements with Siemens affiliates pursuant to which each party has the right to offer licenses and subscriptions to certain technology of the other party both independent of, and in connection with, interoperable solutions developed under the strategic collaboration agreement. For the years ended December 31, 2017, 2018, and 2019, Siemens paid us \$2.0 million, \$2.4 million, and \$2.6 million, respectively, pursuant to the foregoing arrangements. For the years ended December 31, 2017, 2018, and 2019, we paid Siemens approximately \$903,000, \$968,000, and \$1.0 million, respectively, pursuant to the foregoing arrangements.

### ***Stockholders Agreement***

At the completion of this offering, the Bentleys and certain of their permitted transferees will be parties to an amended and restated stockholders agreement (the "Stockholders Agreement"), to which we will not be a party.

The Stockholders Agreement will provide that the parties thereto, by a majority vote, will have the right to nominate a single slate of nominees for election in each election of our board of directors. Each party to the Stockholders Agreement will agree to vote all of such party's shares to elect such slate of nominees to our board of directors, and no party to the Stockholders Agreement will approve the removal of any director nominated by majority vote without the consent of the parties to the Stockholders Agreement voting with the majority. In addition, the Stockholders Agreement will provide that the parties to the Stockholders Agreement, by a majority vote among them, shall determine the manner in which each party to the Stockholders Agreement shall vote all of the voting shares held by each party to the Stockholders Agreement on all other matters at meetings of the stockholders of the Company. No person who is not a Bentley or a permitted transferee thereof will have the right to participate in any majority vote under the Stockholders Agreement.

The Stockholders Agreement will also set forth certain restrictions on the ability of the parties thereto to freely transfer shares of our Class A common stock, except for permitted transfers to family members, entities controlled by or for the benefit of such party or such party's family members, and parties taking a security interest in shares of our Class A common stock to secure indebtedness. In addition, the Stockholders Agreement will provide the parties thereto with (i) drag-along rights in the event the parties to the Stockholders Agreement determine by a majority vote to sell all shares of our stock held by them, (ii) rights of first refusal in the event a party to the Stockholders Agreement wishes to sell shares of our Class A common stock to a person who is not a permitted transferee and (iii) rights to purchase shares of our Class A common stock held by a party to the Stockholders Agreement prior to their transfer by reason of

bankruptcy or insolvency proceedings, attachment or garnishment, divorce or other involuntary transfer (other than by reason of death).

For information on the beneficial ownership of shares of our common stock by the Bentleys and the Bentley Family, see the section titled “Principal and Selling Stockholders.”

#### **Indemnification of our Directors and Officers**

Upon the completion of this offering, our amended and restated by-laws will require us to indemnify our directors and the officers designated by our board of directors to the fullest extent permitted by Delaware law. Subject to certain limitations, our amended and restated by-laws also require us to advance expenses incurred by our directors and such officers.

#### **Procedures for Approval of Related-Party Transactions**

In connection with the offering of our Class B common stock, we have adopted a written policy relating to the approval of related-party transactions. We will review relationships and transactions in which we and our directors, executive officers or certain stockholders or their immediate family members are participants to determine whether such persons have a direct or indirect material interest. Our legal, accounting, and finance staff will be primarily responsible for the development and implementation of processes and controls to obtain information from our directors and executive officers with respect to related-party transactions and for determining, based on the facts and circumstances, whether we or a related person have a direct or indirect material interest in the transaction.

In addition, our Audit Committee will review and approve or ratify any related-party transaction reaching a certain threshold of significance. In approving or rejecting any such transaction, we expect that our Audit Committee will consider the relevant facts and circumstances available and deemed relevant to the Audit Committee.

Any member of the Audit Committee who is a related person with respect to a transaction under review will not be permitted to participate in the deliberations or vote on approval or ratification of the transaction.

**PRINCIPAL AND SELLING STOCKHOLDERS**

The following table sets forth certain information with respect to the beneficial ownership of our common stock as of September 4, 2020, after giving effect to the Charter Amendments and as adjusted to reflect the sale of shares of our Class B common stock offered by this prospectus (but assuming no exercise of the underwriters' option to purchase additional shares), by:

- each of our executive officers;
- each of our directors and director nominee;
- certain selling stockholders;
- other selling stockholders or groups of each holding less than 1%;
- all of our directors and executive officers as a group; and
- each person known by us to be the beneficial owner of more than five percent of any class of our voting securities.

We have determined beneficial ownership in accordance with the rules of the SEC, and thus it represents sole or shared voting or investment power with respect to our securities. Unless otherwise indicated below, to our knowledge, the persons and entities named in the table have sole voting and sole investment power with respect to all shares that they beneficially owned as set forth opposite such person's name, subject to community property laws where applicable. We have deemed shares of our common stock to be outstanding and beneficially owned by a person for the purpose of computing their percentage ownership if that person has the right to acquire voting or investment power in respect of such common stock within 60 days of September 4, 2020. Our calculation of the percentage of beneficial ownership before the offering is based on 11,601,757 shares of Class A common stock and 247,856,647 shares of Class B common stock outstanding as of September 4, 2020, and, with respect to such percentages following the offering, as adjusted to reflect the issuance of 994,912 total shares of restricted Class B common stock and restricted stock units issued in July 2020 that will vest automatically upon the consummation of this offering, reduced by 32,238 of such restricted stock units that will be settled in cash, and 1,025,461 shares of Class B common stock being sold in this offering following the exercise of stock options for such shares.

Except as otherwise indicated, the address of each of the persons in this table is c/o Bentley Systems, Incorporated, 685 Stockton Drive, Exton, PA 19341.

Name of Beneficial Owner	Common stock beneficially owned before the offering				% of total voting power before the offering <sup>(1)</sup>	Number of shares offered	Common stock beneficially owned after the offering				% of total voting power after the offering <sup>(1)</sup>
	Class A		Class B				Class A		Class B		
	Number	%	Number	%			Number	%	Number	%	
<b>Executive Officers, Directors and Director Nominee:</b>											
Keith A. Bentley <sup>(2)(9)</sup>	3,340,793	28.8%	15,779,747	6.4%	19.3%	—	3,340,793	28.8%	15,779,747	6.3%	19.2%
Barry J. Bentley <sup>(3)(9)</sup>	3,340,793	28.8%	13,575,643	5.5%	18.9%	—	3,340,793	28.8%	13,575,643	5.4%	18.8%
Gregory S. Bentley <sup>(4)(9)</sup>	1,926,509	16.6%	6,480,738	2.6%	10.7%	—	1,926,509	16.6%	6,480,738	2.6%	10.6%
Raymond B. Bentley <sup>(5)(9)</sup>	1,655,397	14.3%	18,811,889	7.6%	11.4%	—	1,655,397	14.3%	18,811,889	7.5%	11.4%
Kirk B. Griswold <sup>(6)</sup>	—	—	477,849	*	*	21,225	—	—	456,624	*	*
Brian F. Hughes	—	—	11,531	*	*	—	—	—	11,531	*	*
Janet B. Haugen	—	—	—	—	—	—	—	—	—	—	—
David J. Hollister <sup>(7)</sup>	—	—	1,491,112	*	*	382,048	—	—	1,109,064	*	*
All executive officers, directors and director nominee as a group (9 persons) <sup>(8)</sup>	10,263,492	88.5%	57,267,763	23.1%	60.7%	403,273	10,263,492	88.5%	56,864,490	22.9%	60.5%
<b>5% Stockholders:</b>											
Richard P. Bentley <sup>(9)</sup>	1,000,000	8.6%	3,000,000	1.2%	5.5%	848,996	1,000,000	8.6%	2,151,004	*	5.3%
Siemens International Holding B.V. <sup>(10)</sup>	—	—	35,569,645	14.4%	6.1%	—	—	—	35,569,645	14.2%	6.1%
<b>Selling Stockholders or Groups of Selling Stockholders<sup>(11)</sup>:</b>											
<b>Stockholders selling in excess of 100,000 shares of Class B common stock:</b>											
Jean-Baptiste Monnier <sup>(12)(15)</sup>	22,500	*	1,874,097	*	*	1,521,115	22,500	*	352,982	*	*
Alton B. Cleveland, Jr. <sup>(13)</sup>	—	—	756,138	*	*	628,257	—	—	127,881	*	*
The Sabina B. Singh M17 Trust	—	—	552,958	*	*	469,459	—	—	83,499	*	*
The Sabina B. Singh 2020 GRAT	—	—	380,000	*	*	322,618	—	—	57,382	*	*
The Singh 2019 Grantor Retained Annuity Trust	—	—	656,720	*	*	283,629	—	—	373,091	*	*
Fidelity Investments Charitable Gift Fund	—	—	292,340	*	*	248,195	—	—	44,145	*	*
Robert W. Mitchell Jr. Profit Sharing Plan	—	—	238,372	*	*	202,377	—	—	35,995	*	*
Malcolm S. Walter <sup>(14)</sup>	—	—	461,226	*	*	232,687	—	—	228,539	*	*
Stylios Camateros	—	—	253,794	*	*	215,470	—	—	38,324	*	*
Suzan E. Willcox <sup>(15)</sup>	145,241	1.3%	2,182,030	*	1.1%	192,912	145,241	1.3%	1,989,118	*	1.1%
George J. Dulchinos <sup>(15)(16)</sup>	25,000	*	355,364	*	*	169,799	25,000	*	185,565	*	*
William R. Whitesell <sup>(17)</sup>	—	—	266,261	*	*	166,770	—	—	99,491	*	*
Alan P. Kiraly <sup>(18)</sup>	—	—	192,016	*	*	161,035	—	—	30,981	*	*
John Riddle <sup>(19)</sup>	—	—	196,678	*	*	119,668	—	—	77,010	*	*
The Bachow Family Trust dated 11/16/2012	—	—	350,025	*	*	106,124	—	—	243,901	*	*
<b>Stockholders selling fewer than 100,000 shares of Class B common stock, each of whom hold less than 0.3% of our Class B common stock:</b>											
U.S. colleagues (198 stockholders) <sup>(11)(15)(20)</sup>	85,024	*	11,984,202	4.8%	2.5%	2,382,874	85,024	*	9,601,328	3.3%	2.1%
Non-U.S. colleagues (194 stockholders) <sup>(11)(15)(21)</sup>	30,500	*	3,127,019	1.3%	*	1,130,386	30,500	*	1,996,633	*	*
U.S. non-colleague selling stockholders (53 stockholders) <sup>(11)(22)</sup>	—	—	3,986,257	1.6%	*	737,270	—	—	3,248,987	1.2%	*
Non-U.S. non-colleague selling stockholders (22 stockholders)	—	—	1,652,651	*	*	207,086	—	—	1,445,565	*	*



- 
- \* Represents beneficial ownership of less than 1% of class.
- (1) Percentage of total voting power represents voting power with respect to all shares of our Class A and Class B common stock, as a single class, and assumes the effectiveness of our Charter Amendments. Upon the completion of this offering, the holders of our Class A common stock will be entitled to 29 votes per share, and holders of our Class B common stock will be entitled to one vote per share. For more information about the voting rights of our Class A and Class B common stock, see the section titled “Description of Capital Stock.” We have deemed shares of our common stock to be outstanding and beneficially owned by a person for the purpose of computing the percentage ownership of that person if that person has the right to acquire voting or investment power in respect of such common stock within 60 days of September 4, 2020.
  - (2) Includes (i) 2,103,211 shares of Class B common stock distributable under our DCP within 60 days of September 4, 2020 assuming Keith A. Bentley’s termination of employment on such date, (ii) 680 shares of restricted Class B common stock that will vest upon the consummation of this offering and (iii) 92,654 shares of Class B common stock held in our 401(k) plan. Excludes 38,805,572 shares of Class B common stock held by various trusts of which Keith A. Bentley’s spouse, family members or third-party trustees serve as trustee and as to which Keith A. Bentley disclaims beneficial ownership.
  - (3) Includes (i) 433,879 shares of Class B common stock that are issuable to Barry J. Bentley pursuant to our DCP in connection with his termination of employment on December 31, 2019 and (ii) 92,654 shares of Class B common stock held in our 401(k) plan. Excludes 33,707,989 shares of Class B common stock held by various trusts of which Barry J. Bentley’s spouse, family members or third-party trustees serve as trustee and as to which Barry J. Bentley disclaims beneficial ownership.
  - (4) Includes (i) 3,472,950 shares of Class B common stock pledged as security for a credit facility from PNC Bank, N.A., (ii) 971,027 shares of Class B common stock distributable under our DCP within 60 days of September 4, 2020 assuming Gregory S. Bentley’s termination of employment on such date, (iii) 680 shares of restricted Class B common stock that will vest upon the consummation of this offering and (iv) 92,654 shares of Class B common stock held in our 401(k) plan. Excludes 29,981,604 shares of Class B common stock held by various trusts of which Gregory S. Bentley’s spouse, family members or third-party trustees serve as trustee and as to which Gregory S. Bentley disclaims beneficial ownership.
  - (5) Includes (i) 680 shares of restricted Class B common stock that will vest upon the consummation of this offering and (ii) 92,654 shares of Class B common stock held in our 401(k) plan. Excludes 2,597,400 shares of Class B common stock held by a trust of which Raymond B. Bentley’s spouse, family members or third-party trustees serve as trustee and as to which Raymond B. Bentley disclaims beneficial ownership.
  - (6) Includes 42,500 shares of Class B common stock issuable pursuant to options that are exercisable within 60 days of September 4, 2020.
  - (7) Includes (i) 509,926 shares of Class B common stock distributable under our DCP within 60 days of September 4, 2020 assuming David J. Hollister’s termination of employment on such date, (ii) 680 shares of restricted Class B common stock that will vest upon the consummation of this offering and (iii) 20,447 shares of Class B common stock held in our 401(k) plan.
  - (8) Includes (i) an aggregate total of 3,660,550 shares of Class B common stock pledged as security for credit facilities from PNC Bank, N.A. and M&T Bank, (ii) 285,707 shares of Class B common stock issuable pursuant to options that are exercisable within 60 days of September 4, 2020, (iii) 4,018,043 shares of Class B common stock distributable under our DCP within 60 days of September 4, 2020 assuming such persons’ termination of employment on such date, (iv) 4,294 restricted shares of Class B common stock which will vest upon the consummation of this offering and (v) 423,699 shares of Class B common stock held in our 401(k) plan. Excludes all shares of Class B common stock held in trust as to which Barry J. Bentley, Gregory S. Bentley, Keith A. Bentley and Raymond B. Bentley disclaim beneficial ownership as set forth above.
  - (9) At the completion of this offering, Barry J. Bentley, Gregory S. Bentley, Keith A. Bentley, Raymond B. Bentley and Richard P. Bentley and certain of their family members will be parties to an amended and restated stockholders agreement, to which we will not be a party. See the section titled “Certain
-

- Relationships and Related Party Transactions — Stockholders Agreement” for information regarding the voting and transfer arrangements among the parties to such agreement.
- (10) All such shares of Class B common stock are held of record by Siemens International Holding B.V., the address of which is c/o Siemens AG, Werner von Siemens Str. 50 91052 Erlangen, Germany.
  - (11) The amounts do not include additional equity awards for Class B common stock that are not exercisable, or for which any service condition would not be satisfied, within 60 days of September 4, 2020.
  - (12) Includes (i) 7,416 shares of Class B common stock distributable under our DCP within 60 days of September 4, 2020 assuming Jean-Baptiste Monnier’s termination of employment on such date, (ii) 1,091 shares of restricted Class B common stock that will vest upon the consummation of this offering and (iii) 36,915 shares of Class B common stock held in our 401(k) plan.
  - (13) Includes 2,112 shares of Class B common stock held in our 401(k) plan.
  - (14) Includes 187,153 shares of Class B common stock distributable under our DCP within 60 days of September 4, 2020.
  - (15) The holders of all of our Class A common stock are included in the Bentley Control Group in respect of their shares of Class A common stock.
  - (16) Includes (i) 5,000 shares of Class B common stock issuable pursuant to options that are exercisable within 60 days of September 4, 2020, (ii) 681 shares of restricted Class B common stock that will vest upon the consummation of this offering and (iii) 68,053 shares of Class B common stock held in our 401(k) plan.
  - (17) Includes 31,150 shares of Class B common stock held in our 401(k) plan.
  - (18) Includes (i) 130,108 shares of Class B common stock issuable pursuant to options that are exercisable within 60 days of September 4, 2020, (ii) 1,539 shares of restricted Class B common stock that will vest upon the consummation of this offering and (iii) 11,153 shares of Class B common stock held in our 401(k) plan.
  - (19) Includes 55,725 shares of Class B common stock held in our 401(k) plan.
  - (20) Includes (i) 2,813,569 shares of Class B common stock issuable pursuant to options that are exercisable within 60 days of September 4, 2020, (ii) 110,437 shares of restricted Class B common stock that will vest upon the consummation of this offering, (iii) 2,448,688 shares of Class B common stock held in our 401(k) plan and (iv) 9,443 shares of Class B common stock distributable under our DCP within 60 days of September 4, 2020 assuming such colleagues’ termination of employment on such date.
  - (21) Includes (i) 1,302,279 shares of Class B common stock issuable pursuant to options that are exercisable within 60 days of September 4, 2020, (ii) 71,826 shares of restricted Class B common stock that will vest upon the consummation of this offering, (iii) 1,732 shares of Class B common stock held in our 401(k) plan on account of prior employment in the United States and (iv) 1,928 shares of Class B common stock distributable under our DCP within 60 days of September 4, 2020 assuming such colleagues’ termination of employment on such date.
  - (22) Includes former Company colleagues who are now employed by Digital Construction Works, Inc. Includes (i) 15,250 shares of Class B common stock issuable pursuant to options that are exercisable within 60 days of September 4, 2020 and (ii) 349,741 shares of Class B common stock held in our 401(k) plan on account of prior employment with the Company.

## DESCRIPTION OF CAPITAL STOCK

### General

The following is a summary of certain of the rights of our capital stock and related provisions of our amended and restated certificate of incorporation and amended and restated by-laws that will be in effect upon the completion of this offering. For more detailed information, we refer you to the forms of our amended and restated certificate of incorporation and amended and restated by-laws that are filed as exhibits to the registration statement of which this prospectus is a part and to applicable provisions of Delaware law. Note 11 to our audited consolidated financial statements included elsewhere in this prospectus includes a description of the terms of our Class B common stock pursuant to our amended and restated certificate of incorporation then in effect for the periods reported and does not reflect the Charter Amendments.

Upon the completion of this offering, under our amended and restated certificate of incorporation, we will provide for two classes of common stock: Class A common stock, which will have 29 votes per share, and Class B common stock, which will have one vote per share. The beneficial owners of our Class A common stock are primarily the Bentleys. Any holder of Class A common stock may convert all or a portion of such holder's shares at any time into shares of Class B common stock on a share-for-share basis. In addition, Class A common stock will convert automatically into Class B common stock upon the occurrence of specified events, including transfers, except for certain permitted transfers described below. Except as specified below, the holders of Class A and Class B common stock will vote together as a single class. Except as expressly provided in our amended and restated certificate of incorporation, including with respect to voting rights and conversion rights, the rights of the two classes of common stock are identical. In addition, our amended and restated certificate of incorporation authorizes shares of undesignated preferred stock, the rights, preferences and privileges of which may be designated from time to time by our board of directors.

Upon the completion of this offering, our authorized capital stock will consist of 2,000,000,000 shares, each with a par value of \$0.01 per share, of which:

- 100,000,000 shares are designated as Class A common stock;
- 1,800,000,000 shares are designated as Class B common stock; and
- 100,000,000 shares are undesignated preferred stock.

As of June 30, 2020, we had outstanding 11,601,757 shares of Class A common stock held of record by 17 stockholders, 247,607,598 shares of Class B common stock held of record by 807 stockholders, and no shares of preferred stock, 15,999,363 shares of Class B common stock issuable upon exercise of stock options outstanding as of June 30, 2020 at a weighted average exercise price of \$6.34 per share of Class B common stock (which does not give effect to the exercise price adjustment in connection with the Special Dividend), 45,151 shares of Class B common stock issuable upon the settlement of restricted stock units outstanding as of June 30, 2020, and 27,941,520 shares of Class B common stock held by colleagues and directors as phantom shares under our DCPs as of June 30, 2020. In addition, in July 2020 we granted 994,912 total shares of restricted Class B common stock and restricted stock units that will vest automatically upon the consummation of this offering, with 32,238 of such restricted stock units that will be settled in cash, and there are 1,311,447 shares of unvested restricted Class B common stock and restricted stock units that will not vest upon consummation of this offering.

### Common Stock

#### *Dividend Rights*

Subject to preferences that may apply to shares of preferred stock outstanding at the time, the holders of outstanding shares of our common stock are entitled to receive dividends out of funds legally available if our board of directors, in its discretion, determines to issue dividends and only then at the times and in the amounts that our board of directors may determine. See the section titled "Dividend Policy" for more information.

***Voting Rights***

Upon the completion of this offering, the holders of our Class A common stock will be entitled to 29 votes per share, provided, however, that at any such time, and thereafter, as none of Barry J. Bentley, Gregory S. Bentley, Keith A. Bentley or Raymond B. Bentley is an executive officer or director of the Company, the holders of our Class A common stock will be entitled to 11 votes per share. Upon the completion of this offering, holders of our Class B common stock, which is the class of common stock that the selling stockholders are selling pursuant to this prospectus and is the only class that will be publicly traded and listed, will be entitled to one vote per share. The holders of our Class A common stock and Class B common stock vote together as a single class, unless otherwise required by our amended and restated certificate of incorporation or law. Delaware law could require either holders of our Class A common stock or our Class B common stock to vote separately as a single class in the following circumstances:

- If we were to seek to amend our amended and restated certificate of incorporation to increase or decrease the par value of a class of stock, then that class would be required to vote separately to approve the proposed amendment; and
- If we were to seek to amend our amended and restated certificate of incorporation in a manner that alters or changes the powers, preferences or special rights of a class of stock in a manner that affected its holders adversely, then that class would be required to vote separately to approve the proposed amendment.

In addition, the affirmative vote of the holders of the Class A common stock is required to amend the provisions of our amended and restated certificate of incorporation that relate to our dual class structure.

Under our amended and restated certificate of incorporation, we are not able to engage in certain mergers or other transactions in which the holders of Class A common stock and Class B common stock are not given the same consideration, without the affirmative vote of the holders of a majority of the outstanding shares of Class A common stock, voting separately as a class, and Class B common stock, voting separately as a class. No such separate class vote will be required, however, if the holders of each class of common stock receive equity securities in the surviving entity with voting and related rights substantially similar to the rights of the class of common stock held by such holders prior to the merger or other transaction.

Except as otherwise required by Delaware law, all stockholder action, other than the election of directors, is decided by the vote of the holders of a majority in voting power of the shares of our capital stock issued and outstanding at a meeting in which a quorum, consisting of a majority in voting power of the shares of our capital stock issued and outstanding and entitled to vote at the meeting, is present. The election of directors is determined by a plurality of the votes cast in respect of the shares present at the meeting and entitled to vote on the election of directors. Stockholders do not have the ability to cumulate votes for the election of directors. Our amended and restated by-laws provide that the number of directors will be determined from time to time by resolution of our board of directors.

***No Preemptive or Similar Rights***

Holders of our common stock are not entitled to preemptive rights and are not subject to redemption or sinking fund provisions.

***Right to Receive Liquidation Distributions***

Upon our dissolution, liquidation or winding-up, the assets legally available for distribution to our stockholders are distributable ratably among the holders of our common stock, subject to prior satisfaction of all outstanding debt and liabilities and the preferential rights of and the payment of liquidation preferences, if any, on any outstanding shares of preferred stock.

***Conversion***

Our Class B common stock is not convertible into any other shares of capital stock. Each outstanding share of Class A common stock is convertible at any time at the option of the holder into one share of Class B

common stock. In addition, each share of Class A common stock will convert automatically into one share of Class B common stock upon the occurrence of specified events, including any transfer, whether or not for value, except for certain transfers described in our amended and restated certificate of incorporation, including transfers to family members, trusts primarily for the benefit of the stockholder or the stockholder's family members, certain entities or fiduciaries controlled by the stockholder or the stockholder's family members, and transfers by operation of law pursuant to a qualified domestic order or in connection with a divorce settlement. Each share of Class A common stock will also convert automatically into one share of Class B common stock upon the death of a Class A common stockholder, except if such shares are transferred in accordance with the foregoing sentence. Further, each share of Class A common stock will convert into one share of Class B common stock if such conversion is approved by the holders of at least 90% of the then-outstanding shares of Class A common stock or if the Bentley Family ceases to beneficially own, in the aggregate, at least 20% of the issued and outstanding shares of Class B common stock (on a fully diluted basis and assuming the conversion of all issued and outstanding shares of Class A common stock). Once converted into Class B common stock, a share of Class A common stock may not be reissued.

### **Options**

As of June 30, 2020, there were outstanding options to purchase 15,999,363 shares of our Class B common stock.

### **Restricted Stock and Restricted Stock Units**

As of June 30, 2020, there were outstanding restricted stock units representing 45,151 shares of our Class B common stock.

As of June 30, 2020, there were outstanding 125,488 shares of restricted Class B common stock.

On July 10, 2020 and July 21, 2020, we granted a total of 179,188 and 6,136 shares of restricted stock and restricted stock units, respectively, under our 2015 Plan, at a grant date fair value of \$15.48 per share, all of which were subject to performance-based vesting as determined by the achievement of certain business growth targets which include growth in annual recurring revenues as well as actual bookings for perpetual licenses and non-recurring services. 37,237 of such shares of restricted stock and restricted stock units issued in July 2020 have vested. Annual performance targets are seasonalized and targets are set for quarterly and annual performance periods ending on December 31, 2020. These performance-based restricted shares carry dividend, but not voting rights.

On July 10, 2020, we granted a total of 189,188 shares of restricted stock and restricted stock units under the 2015 Plan at a grant date fair value of \$15.48 per share, of which 179,188 vest ratably on each of the first four anniversaries of the grant date and 10,000 vest ratably on July 13, 2021 and the three subsequent anniversaries of that date. These restricted shares and units do not have voting rights and any dividends declared accrue on such shares and are paid only upon vesting.

On July 10, 2020, our board of directors approved the grant of 994,912 total shares of restricted stock and restricted stock units under the 2015 Plan to substantially all of our full-time colleagues, including 680 shares to each named executive officer, that vest upon the earlier of December 31, 2020 or the consummation of this offering.

On July 21, 2020, we granted a total of 1,020,472 shares of restricted stock and restricted stock units under the 2015 Plan at a grant date fair value of \$15.48 per share, which vest ratably on each of the first four anniversaries of the grant date. These restricted shares and units do not have voting rights and any dividends declared accrue on such shares and are paid only upon vesting.

### **DCP Phantom Shares**

As of June 30, 2020, there were outstanding 27,941,520 phantom shares of our Class B common stock pursuant to our DCPs. See the section titled "Executive and Director Compensation — Other Benefits and Perquisites — Nonqualified Deferred Compensation."

## Registration Rights

See the section titled “Certain Relationships and Related Party Transactions — Registration Rights Agreement” for more information about registration rights of existing stockholders.

## Anti-Takeover Provisions

The provisions of our amended and restated certificate of incorporation and amended and restated by-laws and of the DGCL summarized below may have an anti-takeover effect and may delay, deter, or prevent a tender offer or takeover attempt that you might consider in your best interest, including an attempt that might result in your receipt of a premium over the market price for your shares of Class B common stock. We believe that the benefits of increased protection of our potential ability to negotiate with an unfriendly or unsolicited acquirer outweigh the disadvantages of discouraging a proposal to acquire us because negotiation of these proposals could result in an improvement of their terms.

### *Section 203 of the Delaware General Corporation Law*

We intend to opt out of Section 203 of the DGCL. However, our amended and restated certificate of incorporation will contain provisions that are similar to Section 203. Specifically, our amended and restated certificate of incorporation will provide that, subject to certain exceptions, we will not be able to engage in a “business combination” with any “interested stockholder” for three years following the date that the person became an interested stockholder, unless the interested stockholder attained such status with the approval of our board of directors or unless the business combination is approved in prescribed manner. A “business combination” includes, among other things, a merger or consolidation involving us and the “interested stockholder” and the sale of more than 10% of our assets. In general, an “interested stockholder” is any entity or person beneficially owning 15% or more of our outstanding voting stock and any entity or person affiliated with or controlling or controlled by such entity or person. However, in our case, the Bentley Family and any of their respective direct or indirect transferees receiving 15% or more of our outstanding voting stock will not be deemed to be interested stockholders regardless of the percentage of our outstanding voting stock owned by them, and accordingly will not be subject to such restrictions.

### *Certificate of Incorporation and By-law Provisions*

Our amended and restated certificate of incorporation and our amended and restated by-laws will include a number of provisions that could deter hostile takeovers or delay or prevent changes in control of our board of directors or management team, including the following:

- *Stockholder Action by Written Consent.* Pursuant to Section 228 of the DGCL, any action required to be taken at any annual or special meeting of the stockholders may be taken without a meeting, without prior notice and without a vote if a consent or consents in writing, setting forth the action so taken, is signed by the holders of outstanding stock having not less than the minimum number of votes that would be necessary to authorize or take such action at a meeting at which all shares of our stock entitled to vote thereon were present and voted, unless our amended and restated certificate of incorporation provides otherwise. Our amended and restated certificate of incorporation prohibits stockholder action by written consent (and, thus, requires that all stockholder actions be taken at a meeting of our stockholders), if the Bentley Family ceases to own a majority of the voting power of our outstanding capital stock.
- *Special Meetings of Stockholders.* Our amended and restated certificate of incorporation and amended and restated by-laws further provide that special meetings of our stockholders may be called only by a majority of our total number of directors, the chair of our board of directors, our chief executive officer, or our president (in the absence of a chief executive officer). This provision could have the effect of preventing or delaying significant corporate actions that would otherwise be taken by the holders of at least a majority of the combined voting power of our Class A and Class B common stock.
- *Advance Notice Requirements for Stockholder Proposals and Director Nominations.* Our amended and restated by-laws provide advance notice procedures for stockholders seeking to bring business before our annual meeting of stockholders or to nominate candidates for election as directors at any

meeting of stockholders. Our amended and restated by-laws also specify certain requirements regarding the form and content of a stockholder's notice. These provisions may preclude our stockholders from bringing matters before our annual meeting of stockholders or from making nominations for directors at our meetings of stockholders if proper procedures are not followed. We expect that these provisions may also discourage or deter a potential acquirer from conducting a solicitation of proxies to elect the acquirer's own slate of directors or otherwise attempting to obtain control of our company.

- *Authorized but Unissued Shares.* The authorized but unissued shares of our Class A and Class B common stock will be available for future issuance without stockholder approval, subject to any limitations imposed by the listing standards of The Nasdaq Global Select Market. These additional shares may be utilized for a variety of corporate purposes, including future public offerings to raise additional capital, corporate acquisitions and employee benefit plans. The existence of authorized but unissued shares of Class A and Class B common stock enables our board of directors to make more difficult or to discourage an attempt to obtain control of us by means of a merger, tender offer, proxy contest or otherwise.
- *"Blank Check" Preferred Stock.* Our amended and restated certificate of incorporation allows our board of directors to, without prior stockholder approval, issue shares of authorized, undesignated preferred stock with dividend, liquidation, conversion, voting or other rights that could adversely affect the relative voting power or other rights of our common stock. The existence of such authorized but unissued shares of preferred stock may enable our board of directors to discourage an attempt to acquire control of our company, whether by means of a merger, tender offer, proxy contest or otherwise.
- *No Cumulative Voting.* The DGCL provides that stockholders are not entitled to cumulate votes in the election of directors unless a corporation's certificate of incorporation provides otherwise. Our amended and restated certificate of incorporation will not provide for cumulative voting.
- *Amendment of Certificate of Incorporation or By-laws.* The DGCL provides generally that the affirmative vote of a majority of the shares entitled to vote on any matter is required to amend a corporation's certificate of incorporation or by-laws, unless a corporation's certificate of incorporation, or by-laws, as the case may be, requires a greater percentage. Our by-laws may be amended or repealed by a majority vote of our board of directors or pursuant to the affirmative vote of the holders of at least 66 $\frac{2}{3}$ % of the voting power of the capital stock of the corporation. In addition, the affirmative vote of the holders of at least 66 $\frac{2}{3}$ % of the voting power of the capital stock of the corporation will be required to amend or repeal or to adopt any provisions inconsistent with any of the provisions of our certificate described above.

### **Stockholder Litigation Matters**

Our amended and restated certificate of incorporation provides that the Court of Chancery of the State of Delaware will be the exclusive forum for any derivative action or proceeding brought on our behalf; any action asserting a breach of fiduciary duty owed to us; any action asserting a claim arising pursuant to the DGCL, our amended and restated certificate of incorporation or our amended and restated by-laws; any action to interpret, apply, enforce or determine the validity of any provision of our amended and restated certificate of incorporation or our amended and restated by-laws; or any action asserting a claim that is governed by the internal affairs doctrine. The federal district court for the District of Delaware will be the exclusive forum for any claims brought under the Securities Act or the Exchange Act, as the Company is incorporated in the State of Delaware. The enforceability of similar choice of forum provisions in other companies' certificates of incorporation has been challenged in legal proceedings, and it is possible that a court could find these types of provisions to be inapplicable or unenforceable.

### **Limitations on Liability and Indemnification**

See the section titled "Executive and Director Compensation — Limitations on Liability and Indemnification Matters."

**Listing**

Our Class B common stock has been approved for listing on The Nasdaq Global Select Market under the symbol “BSY.” Our Class A common stock will not be listed on any stock market or exchange.

**Transfer Agent and Registrar**

The transfer agent and registrar for our common stock is Computershare Trust Company, N.A. The transfer agent’s address is 150 Royall Street, Canton, MA 02021.



## SHARES ELIGIBLE FOR FUTURE SALE

Before this offering, there has been no public market for our common stock, and a liquid trading market for our common stock may not develop or be sustained after this offering. We cannot predict the effect, if any, that market sales of shares of our common stock or the availability of shares of our common stock for sale will have on the market price of our common stock prevailing from time to time. Future sales of substantial amounts of our Class B common stock in the public market, or the perception that such sales could occur, could adversely affect market prices prevailing from time to time, may make it more difficult for you to sell your Class B common stock at a time and price that you deem appropriate and could impair our ability to raise capital through the sale of our equity securities. Furthermore, because only a limited number of shares will be available for sale shortly after this offering due to existing contractual and legal restrictions on resale as described below, there may be sales of substantial amounts of our Class B common stock in the public market after the restrictions lapse. This circumstance may adversely affect the prevailing market price and our ability to raise equity capital in the future. Although our Class B common stock has been approved for listing on The Nasdaq Global Select Market under the symbol “BSY,” we cannot assure you that there will be an active public market for our Class B common stock.

Based on the number of shares outstanding as of June 30, 2020 and after giving effect to (A) 994,912 total shares of restricted Class B common stock and restricted stock units issued in July 2020 that will vest automatically upon the consummation of this offering, reduced by 32,238 of such restricted stock units that will be settled in cash, (B) 1,025,461 shares of Class B common stock to be sold in this offering following the exercise of stock options for such shares, and (C) 37,237 vested shares of restricted Class B common stock and restricted stock units issued in July 2020, 11,601,757 shares of our Class A common stock and 249,632,970 shares of our Class B common stock will be outstanding. Of the shares to be outstanding immediately after the closing of this offering, the 10,750,000 shares of our Class B common stock to be sold in this offering will be freely tradable without restriction under the Securities Act unless purchased by our “affiliates,” as that term is defined in Rule 144 under the Securities Act.

The remaining 237,271,979 shares of our Class B common stock (assuming exercise of the underwriters’ option to purchase additional shares) and all of the shares of our Class A common stock will be “restricted securities” under Rule 144.

These restricted securities will be available for sale in the public market as follows: (i) 5,444,277 shares of our Class B common stock will not be subject to a lock-up and will be salable subject to compliance with Rules 144 and 701 under the Securities Act and (ii) 231,827,702 shares of our Class B common stock will be subject to a lock-up and, upon release 180 days after the date of the prospectus, will be salable subject to compliance with Rules 144 and 701 under the Securities Act.

In addition, of the 15,999,363 shares of Class B common stock that were issuable upon exercise of stock options outstanding as of June 30, 2020, options to purchase 8,412,929 shares of our Class B common stock were exercisable as of that date, and upon exercise these shares will be eligible for sale, subject to the lock-up agreements described below and Rules 144 and 701 under the Securities Act.

### Lock-Up Restrictions

In connection with this offering, our directors, executive officers, and holders of substantially all of our common stock and securities convertible into or exchangeable for our common stock (including the selling stockholders, but excluding the shares sold by them in this offering) have entered into lock up agreements with Goldman Sachs & Co. LLC (“Goldman Sachs”) under which they may not, subject to specific exceptions, sell any of our common stock for 180 days after the date of this prospectus without the prior written consent of Goldman Sachs. Goldman Sachs may, at its discretion, remove or reduce the lock-up restrictions applicable to any number of shares of our common stock on terms and conditions and in ratios and numbers that it may fix in its sole discretion. Siemens is subject to a contractual lock-up pursuant to the Common Stock Agreement with us, as described in the section titled “Certain Relationships and Related Party Transactions — Our Relationship with Siemens — Common Stock Purchase Agreement.” The Company lock-up contained in the underwriting agreement entered into by us with the underwriters in this offering will permit us and selling stockholders to sell shares of Class B common stock in an aggregate amount equal to

up to 20% of our total Class B common stock outstanding at such time beginning on December 1, 2020. This agreement does not apply to any existing employee benefit plans. See the section titled “Underwriting.”

After this offering, our colleagues, including our executive officers and our directors, may enter into written trading plans that are intended to comply with Rule 10b5-1 under the Exchange Act. Sales under these trading plans would not be permitted until the expiration of the lock-up provisions described above.

#### **Rule 144**

In general, under Rule 144 as currently in effect, once we have been subject to public company reporting requirements for at least 90 days, a person who is not deemed to have been one of our affiliates for purposes of the Securities Act at any time during the 90 days preceding a sale and who has beneficially owned the shares proposed to be sold for at least six months, including the holding period of any prior owner other than our affiliates, is entitled to sell those shares without complying with the manner of sale, volume limitation or notice provisions of Rule 144, subject to compliance with the public information requirements of Rule 144. If such a person has beneficially owned the shares proposed to be sold for at least one year, including the holding period of any prior owner other than our affiliates, then that person is entitled to sell those shares without complying with any of the requirements of Rule 144.

In general, under Rule 144, as currently in effect, our affiliates or persons selling shares on behalf of our affiliates are entitled to sell, within any three-month period beginning 90 days after the date of this prospectus, a number of shares that does not exceed the greater of:

- 1% of the number of shares of Class B common stock then outstanding, which will equal approximately 2.496 million shares immediately after our initial public offering based on shares outstanding as of June 30, 2020; or
- the average weekly trading volume of our Class B common stock during the four calendar weeks preceding the filing of a notice on Form 144 with respect to such sale.

Rule 144 does not supersede the terms of the lock-up agreements described above, which may restrict sales of shares of our Class B common stock for 180 days from the date of this prospectus. Sales under Rule 144 by our affiliates or persons selling shares on behalf of our affiliates are also subject to certain manner of sale provisions and notice requirements and to the availability of current public information about us.

#### **Rule 701**

Under Rule 701, common stock acquired upon the exercise of certain currently outstanding options or pursuant to other rights granted under our stock plans may be resold, to the extent not subject to lock-up agreements, (a) by persons other than affiliates, beginning 90 days after the effective date of this offering, and (b) by affiliates, subject to the manner-of-sale, volume limitations, current public information and filing requirements of Rule 144, in each case, without compliance with the holding period requirement of Rule 144.

#### **Registration Rights**

In connection with the Common Stock Purchase Agreement, we and an affiliate of Siemens entered into a registration rights agreement. Beginning eighteen months following the effectiveness of the registration statement of which this prospectus forms a part, Siemens may request one consummated registration by the Company of its shares on Form S-1 and unlimited registrations on Form S-3 (to the extent available, and no more than two per year). In addition, subject to certain exceptions, if we propose to register any of our securities under the Securities Act in connection with the public offering of such securities, upon the request of Siemens, we will register all of the capital stock that Siemens has requested to be included in such registration, subject to any proportionate cut back at the request of any underwriter used in connection with such registration. In connection with any of these the registrations, we will indemnify Siemens and we will bear all fees, costs and expenses (except underwriting commissions and discounts).

**Form S-8 Registration Statement**

We intend to file a registration statement on Form S-8 under the Securities Act covering all of the shares of our Class B common stock issuable or reserved for issuance under our 2015 Equity Incentive Plan, the DCP, the 2020 Incentive Award Plan, the Global ESPP and our future compensation plans and programs currently under consideration. We expect to file that registration statement as soon as practicable after this offering. To the extent not subject to the Rule 144 limitations applicable to affiliates, vesting restrictions, and lock-up agreements, the shares registered on Form S-8 will be eligible for resale.

## MATERIAL U.S. FEDERAL INCOME TAX CONSEQUENCES TO NON-U.S. HOLDERS

The following discussion is a summary of the material U.S. federal income tax consequences to Non-U.S. Holders (as defined below) of the purchase, ownership, and disposition of our common stock, but does not purport to be a complete analysis of all potential tax effects. The effects of other U.S. federal tax laws, such as estate and gift tax laws, and any applicable state, local or non-U.S. tax laws are not discussed. This discussion is based on the Code, Treasury Regulations promulgated thereunder, judicial decisions, and published rulings and administrative pronouncements of the U.S. Internal Revenue Service (the “IRS”), in each case in effect as of the date hereof. These authorities may change or be subject to differing interpretations. Any such change or differing interpretation may be applied retroactively in a manner that could adversely affect a Non-U.S. Holder of our common stock. We have not sought and will not seek any rulings from the IRS regarding the matters discussed below. There can be no assurance the IRS or a court will not take a contrary position to that discussed below regarding the tax consequences of the purchase, ownership and disposition of our common stock.

This discussion is limited to Non-U.S. Holders that hold our common stock as a “capital asset” within the meaning of Section 1221 of the Code (generally, property held for investment). This discussion does not address all U.S. federal income tax consequences relevant to a Non-U.S. Holder’s particular circumstances, including the impact of the alternative minimum tax or the Medicare contribution tax on net investment income. In addition, it does not address consequences relevant to Non-U.S. Holders subject to special rules, including, without limitation:

- U.S. expatriates and former citizens or long-term residents of the United States;
- persons holding our common stock as part of a hedge, straddle or other risk reduction strategy or as part of a conversion transaction or other integrated investment;
- banks, insurance companies, and other financial institutions;
- brokers, dealers or traders in securities;
- “controlled foreign corporations,” “passive foreign investment companies,” and corporations that accumulate earnings to avoid U.S. federal income tax;
- partnerships or other entities or arrangements treated as partnerships for U.S. federal income tax purposes (and investors therein);
- tax-exempt organizations or governmental organizations;
- persons deemed to sell our common stock under the constructive sale provisions of the Code;
- persons who hold or receive our common stock pursuant to the exercise of any employee stock option or otherwise as compensation;
- tax-qualified retirement plans;
- “qualified foreign pension funds” as defined in Section 897(1)(2) of the Code and entities all of the interests of which are held by qualified foreign pension funds; and
- persons subject to special tax accounting rules as a result of any item of gross income with respect to the stock being taken into account in an “applicable financial statement” (as defined in the Code).

If an entity treated as a partnership for U.S. federal income tax purposes holds our common stock, the tax treatment of a partner in the partnership will depend on the status of the partner, the activities of the partnership and certain determinations made at the partner level. Accordingly, partnerships holding our common stock and the partners in such partnerships should consult their tax advisors regarding the U.S. federal income tax consequences to them.

**THIS DISCUSSION IS FOR INFORMATION PURPOSES ONLY AND IS NOT TAX OR LEGAL ADVICE. INVESTORS SHOULD CONSULT THEIR TAX ADVISORS WITH RESPECT TO THE APPLICATION OF THE U.S. FEDERAL INCOME TAX LAWS TO THEIR PARTICULAR SITUATIONS AS WELL AS ANY TAX CONSEQUENCES OF THE PURCHASE, OWNERSHIP AND DISPOSITION OF OUR COMMON STOCK ARISING UNDER THE U.S. FEDERAL ESTATE OR**

**GIFT TAX LAWS OR UNDER THE LAWS OF ANY STATE, LOCAL OR NON-U.S. TAXING JURISDICTION OR UNDER ANY APPLICABLE INCOME TAX TREATY.**

**Definition of a Non-U.S. Holder**

For purposes of this discussion, a “Non-U.S. Holder” is any beneficial owner of our common stock that is neither a “U.S. person” nor an entity treated as a partnership for U.S. federal income tax purposes. A U.S. person is any person that, for U.S. federal income tax purposes, is or is treated as any of the following:

- an individual who is a citizen or resident of the United States;
- a corporation created or organized under the laws of the United States, any state thereof, or the District of Columbia;
- an estate, the income of which is subject to U.S. federal income tax regardless of its source; or
- a trust that (1) is subject to the primary supervision of a U.S. court and the control of one or more “United States persons” (within the meaning of Section 7701(a)(30) of the Code), or (2) has a valid election in effect to be treated as a United States person for U.S. federal income tax purposes.

**Distributions**

As described in the section titled “Dividend Policy,” the declaration and payment of dividends is within the discretion of our board of directors. If we do make distributions of cash or property on our common stock, such distributions will constitute dividends for U.S. federal income tax purposes to the extent paid from our current or accumulated earnings and profits, as determined under U.S. federal income tax principles. Amounts not treated as dividends for U.S. federal income tax purposes will constitute a return of capital and first be applied against and reduce a Non-U.S. Holder’s adjusted tax basis in its common stock, but not below zero. Any excess will be treated as capital gain and will be treated as described below under “— Sale or Other Taxable Disposition.”

Subject to the discussion below on effectively connected income, dividends paid to a Non-U.S. Holder of our common stock will be subject to U.S. federal withholding tax at a rate of 30% of the gross amount of the dividends (or such lower rate specified by an applicable income tax treaty, provided the Non-U.S. Holder furnishes a valid IRS Form W-8BEN or W-8BEN-E (or other applicable documentation) certifying qualification for the lower treaty rate). If a Non-U.S. Holder holds the stock through a financial institution or other intermediary, the Non-U.S. Holder will be required to provide appropriate documentation to the intermediary, which then will be required to provide certification to the applicable withholding agent, either directly or through other intermediaries. A Non-U.S. Holder that does not timely furnish the required documentation, but that qualifies for a reduced treaty rate, may obtain a refund of any excess amounts withheld by timely filing an appropriate claim for refund with the IRS. Non-U.S. Holders should consult their tax advisors regarding their entitlement to benefits under any applicable income tax treaty.

If dividends paid to a Non-U.S. Holder are effectively connected with the Non-U.S. Holder’s conduct of a trade or business within the United States (and, if required by an applicable income tax treaty, the Non-U.S. Holder maintains a permanent establishment in the United States to which such dividends are attributable), the Non-U.S. Holder will be exempt from the U.S. federal withholding tax described above. To claim the exemption, the Non-U.S. Holder must furnish to the applicable withholding agent a valid IRS Form W-8ECI, certifying that the dividends are effectively connected with the Non-U.S. Holder’s conduct of a trade or business within the United States.

Any such effectively connected dividends will be subject to U.S. federal income tax on a net income basis at the regular graduated rates applicable to U.S. persons. A Non-U.S. Holder that is a corporation also may be subject to a branch profits tax at a rate of 30% (or such lower rate specified by an applicable income tax treaty) on such effectively connected dividends, as adjusted for certain items. Non-U.S. Holders should consult their tax advisors regarding any applicable tax treaties that may provide for different rules.

Any documentation provided to an applicable withholding agent may need to be updated in certain circumstances. The certification requirements described above also may require a Non-U.S. Holder to provide its U.S. taxpayer identification number.

### **Sale or Other Taxable Disposition**

A Non-U.S. Holder will not be subject to U.S. federal income tax on any gain realized upon the sale or other taxable disposition of our common stock unless:

- the gain is effectively connected with the Non-U.S. Holder's conduct of a trade or business within the United States (and, if required by an applicable income tax treaty, the Non-U.S. Holder maintains a permanent establishment in the United States to which such gain is attributable);
- the Non-U.S. Holder is a nonresident alien individual present in the United States for 183 days or more during the taxable year of the disposition and certain other requirements are met; or
- our common stock constitutes a U.S. real property interest, by reason of our status as a U.S. real property holding corporation ("USRPHC"), for U.S. federal income tax purposes.

Gain described in the first bullet point above generally will be subject to U.S. federal income tax on a net income basis at the regular graduated rates applicable to U.S. persons. A Non-U.S. Holder that is a corporation also may be subject to a branch profits tax at a rate of 30% (or such lower rate specified by an applicable income tax treaty) on such effectively connected gain, as adjusted for certain items.

A Non-U.S. Holder described in the second bullet point above will be subject to U.S. federal income tax at a rate of 30% (or such lower rate specified by an applicable income tax treaty) on any gain, which may be offset by U.S. source capital losses of the Non-U.S. Holder (even though the individual is not considered a resident of the United States), provided the Non-U.S. Holder has timely filed U.S. federal income tax returns with respect to such losses.

With respect to the third bullet point above, we believe we currently are not, and do not anticipate becoming, a USRPHC.

Non-U.S. Holders should consult their tax advisors regarding potentially applicable income tax treaties that may provide for different rules.

### **Information Reporting and Backup Withholding**

Payments of dividends on our common stock to a Non-U.S. Holder generally will not be subject to backup withholding, provided the Non-U.S. Holder certifies its non-U.S. status, such as by furnishing a valid IRS Form W-8BEN, W-8BEN-E or W-8ECI, or otherwise establishes an exemption. Notwithstanding the foregoing, backup withholding may apply if the applicable withholding agent has actual knowledge, or reason to know, that the holder is a United States person that is not an exempt recipient. However, information returns are required to be filed with the IRS in connection with any dividends on our common stock paid to the Non-U.S. Holder, regardless of whether any tax was actually withheld. In addition, proceeds of the sale or other taxable disposition of our common stock within the United States or conducted through certain U.S.-related brokers generally will not be subject to backup withholding or information reporting, if the applicable withholding agent receives the certification described above and does not have actual knowledge or reason to know that such holder is a United States person, or the holder otherwise establishes an exemption. Proceeds of a disposition of our common stock conducted through a non-U.S. office of a non-U.S. broker (other than certain U.S.-related brokers) generally will not be subject to backup withholding or information reporting.

Copies of information returns that are filed with the IRS may also be made available under the provisions of an applicable treaty or agreement to the tax authorities of the country in which the Non-U.S. Holder resides or is established.

Backup withholding is not an additional tax. Any amounts withheld under the backup withholding rules may be allowed as a refund or a credit against a Non-U.S. Holder's U.S. federal income tax liability, provided the required information is timely furnished to the IRS.

### **Additional Withholding Tax on Payments Made to Foreign Accounts**

Withholding taxes may be imposed under Sections 1471 to 1474 of the Code (such Sections commonly referred to as the Foreign Account Tax Compliance Act ("FATCA")) on certain types of payments made to

non-U.S. financial institutions and certain other non-U.S. entities. Specifically, a 30% withholding tax may be imposed on dividends on, or (subject to the proposed Treasury Regulations discussed below) gross proceeds from the sale or other disposition of, our common stock paid to a “foreign financial institution” or a “non-financial foreign entity” (each as defined in the Code), unless (1) the foreign financial institution undertakes certain diligence and reporting obligations, (2) the non-financial foreign entity either certifies it does not have any “substantial United States owners” (as defined in the Code) or furnishes identifying information regarding each substantial United States owner, or (3) the foreign financial institution or non-financial foreign entity otherwise qualifies for an exemption from these rules. If the payee is a foreign financial institution and is subject to the diligence and reporting requirements in (1) above, it must enter into an agreement with the U.S. Department of the Treasury requiring, among other things, that it undertake to identify accounts held by certain “specified United States persons” or “United States owned foreign entities” (each as defined in the Code), annually report certain information about such accounts, and withhold 30% on certain payments to non-compliant foreign financial institutions and certain other account holders. Foreign financial institutions located in jurisdictions that have an intergovernmental agreement with the United States governing FATCA may be subject to different rules.

Under the applicable Treasury Regulations and administrative guidance, withholding under FATCA generally applies to payments of dividends on our common stock. While withholding under FATCA would have applied also to payments of gross proceeds from the sale or other disposition of stock on or after January 1, 2019, recently proposed Treasury Regulations eliminate FATCA withholding on payments of gross proceeds entirely. Taxpayers generally may rely on these proposed Treasury Regulations until final Treasury Regulations are issued.

Prospective Non-U.S. Holders should consult their tax advisors regarding the potential application of withholding under FATCA to their investment in our common stock.

## UNDERWRITING

We, the selling stockholders and the underwriters named below have entered into an underwriting agreement with respect to the shares being offered. Subject to certain conditions, each underwriter has severally agreed to purchase the number of shares indicated in the following table. Goldman Sachs & Co. LLC and BofA Securities, Inc. are the representatives of the underwriters.

Underwriters	Number of Shares
Goldman Sachs & Co. LLC	4,669,683
BofA Securities, Inc.	3,424,434
RBC Capital Markets, LLC	948,529
Robert W. Baird & Co. Incorporated	569,118
KeyBanc Capital Markets Inc.	569,118
Mizuho Securities USA LLC	569,118
<b>Total</b>	<b>10,750,000</b>

The underwriters are committed to take and pay for all of the shares being offered, if any are taken, other than the shares covered by the option described below unless and until this option is exercised.

The underwriters have an option to buy up to an additional 1,610,991 shares from the selling stockholders to cover sales by the underwriters of a greater number of shares than the total number set forth in the table above. They may exercise that option for 30 days. If any shares are purchased pursuant to this option, the underwriters will severally purchase shares in approximately the same proportion as set forth in the table above.

We have agreed to pay certain expenses in connection with this offering on behalf of the selling stockholders, including all the underwriting discounts and commissions. The following table shows the per share and total underwriting discounts and commissions to be paid to the underwriters by us. Such amounts are shown assuming both no exercise and full exercise of the underwriters' option to purchase additional shares from the selling stockholders.

	No Exercise	Full Exercise
Per share	\$ 1.54	\$ 1.54
<b>Total</b>	<b>\$16,555,000</b>	<b>\$19,035,926</b>

Shares sold by the underwriters to the public will initially be offered at the initial public offering price set forth on the cover page of this prospectus. Any shares sold by the underwriters to securities dealers may be sold at a discount of up to \$0.79 per share from the initial public offering price. After the initial offering of the shares, the representatives may change the offering price and the other selling terms. The offering of the shares by the underwriters is subject to receipt and acceptance and subject to the underwriters' right to reject any order in whole or in part.

We and our officers, directors, and holders of substantially all of our common stock, including the selling stockholders, have agreed with the underwriters, subject to certain exceptions, not to dispose of or hedge any of their common stock or securities convertible into or exchangeable for shares of common stock during the period from the date of this prospectus continuing through the date 180 days after the date of this prospectus, except with the prior written consent of Goldman Sachs. The Company lock-up contained in the underwriting agreement entered into by us with the underwriters in this offering will permit us and selling stockholders to sell shares of Class B common stock in an aggregate amount equal to up to 20% of our total Class B common stock outstanding at such time beginning on December 1, 2020. This agreement does not apply to any existing employee benefit plans. See the section titled "Shares Available for Future Sale" for a discussion of certain transfer restrictions.

Prior to the offering, there has been no public market for the shares. The initial public offering price has been negotiated among the representatives and us. Among the factors considered in determining the initial public offering price of the shares, in addition to prevailing market conditions, were our historical



performance, estimates of our business potential and earnings prospects, an assessment of our management, and the consideration of the above factors in relation to market valuation of companies in related businesses. Our Class B common stock has been approved for listing on the Nasdaq Global Select Market under the symbol “BSY.”

One or more funds affiliated with Capital Research Global Investors have indicated an interest in purchasing up to an aggregate of \$40 million in shares of our Class B common stock being offered by the selling stockholders in this offering at the initial public offering price. As this indication of interest is not a binding agreement or commitment to purchase, one or more funds affiliated with Capital Research Global Investors may determine to purchase more, fewer or no shares in this offering or the underwriters may determine to sell more, fewer or no shares to one or more funds affiliated with Capital Research Global Investors. The underwriters will receive the same discount from any shares of Class B common stock purchased by one or more funds affiliated with Capital Research Global Investors as they will from any other shares of Class B common stock sold to the public in this offering.

In connection with the offering, the underwriters may purchase and sell shares of common stock in the open market. These transactions may include short sales, stabilizing transactions, and purchases to cover positions created by short sales. Short sales involve the sale by the underwriters of a greater number of shares than they are required to purchase in the offering, and a short position represents the amount of such sales that have not been covered by subsequent purchases. A “covered short position” is a short position that is not greater than the amount of additional shares for which the underwriters’ option described above may be exercised. The underwriters may cover any covered short position by either exercising their option to purchase additional shares or purchasing shares in the open market. In determining the source of shares to cover the covered short position, the underwriters will consider, among other things, the price of shares available for purchase in the open market as compared to the price at which they may purchase additional shares pursuant to the option described above. “Naked” short sales are any short sales that create a short position greater than the amount of additional shares for which the option described above may be exercised. The underwriters must cover any such naked short position by purchasing shares in the open market. A naked short position is more likely to be created if the underwriters are concerned that there may be downward pressure on the price our common stock in the open market after pricing that could adversely affect investors who purchase in the offering. Stabilizing transactions consist of various bids for or purchases of common stock made by the underwriters in the open market prior to the completion of the offering.

The underwriters may also impose a penalty bid. This occurs when a particular underwriter repays to the underwriters a portion of the underwriting discount received by it because the representatives have repurchased shares sold by or for the account of such underwriter in stabilizing or short covering transactions. Purchases to cover a short position and stabilizing transactions, as well as other purchases by the underwriters for their own accounts, may have the effect of preventing or retarding a decline in the market price of our stock, and together with the imposition of the penalty bid, may stabilize, maintain, or otherwise affect the market price of our common stock. As a result, the price of our common stock may be higher than the price that otherwise might exist in the open market. The underwriters are not required to engage in these activities and may end any of these activities at any time. These transactions may be effected on the Nasdaq Global Select Market, in the over-the-counter market, or otherwise.

The underwriters do not expect sales to discretionary accounts to exceed five percent of the total number of shares offered. We have agreed to reimburse the underwriters for certain FINRA-related expenses incurred by them in connection with the offering in an amount not to exceed \$40,000 as set forth in the underwriting agreement.

We estimate that our share of the total expenses of the offering, excluding any underwriting discounts and commissions applicable to the sale of shares by the selling stockholders, will be approximately \$6.1 million. The underwriters have agreed to reimburse us for certain expenses incurred by us in connection with this offering upon closing of this offering.

We and the selling stockholders have agreed to indemnify the several underwriters against certain liabilities, including liabilities under the Securities Act.

The underwriters and their respective affiliates are full service financial institutions engaged in various activities, which may include sales and trading, commercial and investment banking, advisory, investment

management, investment research, principal investment, hedging, market making, brokerage, and other financial and non-financial activities and services. Certain of the underwriters and their respective affiliates have provided, and may in the future provide, a variety of these services to us and to persons and entities with relationships with us, for which they received or will receive customary fees and expenses. An affiliate of BofA Securities, Inc. is a lender under our Credit Facility.

In the ordinary course of their various business activities, the underwriters and their respective affiliates, officers, directors, and employees may purchase, sell, or hold a broad array of investments and actively traded securities, derivatives, loans, commodities, currencies, credit default swaps, and other financial instruments for their own account and for the accounts of their customers, and such investment and trading activities may involve or relate to assets, securities, and/or instruments of ours (directly, as collateral securing other obligations or otherwise) and/or persons and entities with relationships with us. The underwriters and their respective affiliates may also communicate independent investment recommendations, market color, or trading ideas and/or publish or express independent research views in respect of such assets, securities, or instruments and may at any time hold, or recommend to clients that they should acquire, long and/or short positions in such assets, securities, and instruments.

#### ***European Economic Area and the United Kingdom***

In relation to each Member State of the European Economic Area and the United Kingdom has implemented the Prospectus Regulation or each, a Relevant Member State, an offer to the public of our common shares may not be made in that Relevant Member State, except that an offer to the public in that Relevant Member State of our common shares may be made at any time under the following exemptions under the Prospectus Regulation:

- To any legal entity which is a qualified investor as defined in the Prospectus Regulation;
- To fewer than 150 natural or legal persons (other than qualified investors as defined in the Prospectus Regulation), subject to obtaining the prior consent of the representatives for any such offer; or
- In any other circumstances falling within Article 31(4)(2) of the Prospectus Regulation;

provided that no such offer or shares of our common stock shall result in a requirement for the publication by us or any placement agent or underwriter of a prospectus pursuant to Article 3 of the Prospectus Regulation or supplement a prospectus pursuant to Article 23 of the Prospectus Regulation.

Each person in a Relevant Member State who initially acquires any shares of common stock or to whom any offer is made will be deemed to have represented, acknowledged, and agreed to and with the Company and the underwriters that it is a qualified investor within the meaning of the Prospectus Regulation.

In the case of any common stock being offered to a financial intermediary as that term is used in Article 5(1) of the Prospectus Regulation, each such financial intermediary will be deemed to have represented, acknowledged, and agreed that the shares of common stock acquired by it in the offer have not been acquired on a non-discretionary basis on behalf of, nor have they been acquired with a view to their offer or resale to, persons in circumstances which may give rise to an offer to the public other than their offer or resale in a Relevant Member State to qualified investors, in circumstances in which the prior consent of the representatives has been obtained to each such proposed offer or resale.

The Company, the underwriters, and their affiliates will rely upon the truth and accuracy of the foregoing representations, acknowledgements, and agreements.

For the purposes of this provision, the expression an “offer to public” in relation to our common stock in any Relevant Member State means the communication in any form and by any means of sufficient information on the terms of the offer and our common stock to be offered so as to enable an investor to decide to purchase our common stock, as the same may be varied in that Relevant Member State by any measure implementing the Prospectus Directive in that Relevant Member State, the expression “Prospectus Regulation” means Regulation (EU) 2017/1129 and includes any relevant implementing measure in the Relevant Member State.

References to the Prospectus Regulation includes, in relation to the United Kingdom, the Prospectus Regulation as it forms part of UK domestic law by virtue of the European Union (Withdrawal) Act 2018.

This European Economic Area selling restriction is in addition to any other selling restrictions set out below.

### ***United Kingdom***

In the United Kingdom, this prospectus is only addressed to and directed as qualified investors who are (i) investment professionals falling within Article 19(5) of the Financial Services and Markets Act 2000 (Financial Promotion) Order 2005, or the Order, (ii) high net worth entities and other persons to whom it may lawfully be communicated, falling within Article 49(2)(a) to (d) of the Order persons to whom an invitation or inducement to engage in investment activity (within the meaning of Section 21 of the Financial Services and Markets Act 2000, as amended) in connection with the issue or sale of any securities may otherwise lawfully be communicated or caused to be communicated, with all such persons together being referred to as relevant persons. Any investment or investment activity to which this prospectus relates is available only to relevant persons and will only be engaged with relevant persons. Any person who is not a relevant person should not act or rely on this prospectus or any of its contents.

### ***Canada***

The securities may be sold in Canada only to purchasers purchasing, or deemed to be purchasing, as principal that are accredited investors, as defined in National Instrument 45-106 Prospectus Exemptions or subsection 73.3(1) of the Securities Act (Ontario), and are permitted clients, as defined in National Instrument 31-103 Registration Requirements, Exemptions, and Ongoing Registrant Obligations. Any resale of the securities must be made in accordance with an exemption form, or in a transaction not subject to, the prospectus requirements of applicable securities laws.

Securities legislation in certain provinces or territories of Canada may provide a purchaser with remedies for rescission or damages if this prospectus (including any amendment thereto) contains a misrepresentation, provided that the remedies for rescission or damages are exercised by the purchaser within the time limit prescribed by the securities legislation of the purchaser's province or territory. The purchaser should refer to any applicable provisions of the securities legislation of the purchaser's province or territory of these rights or consult with a legal advisor.

Pursuant to section 3A.3 of National Instrument 33-105 Underwriting Conflicts (NI 33-105), the underwriters are not required to comply with the disclosure requirements of NI 33-105 regarding underwriter conflicts of interest in connection with this offering.

### ***Hong Kong***

The shares may not be offered or sold in Hong Kong by means of any document other than (i) in circumstances which do not constitute an offer to the public within the meaning of the Companies (Winding Up and Miscellaneous Provisions) Ordinance (Cap. 32 of the Laws of Hong Kong), or the Companies (Winding Up and Miscellaneous Provisions) Ordinance, or which do not constitute an invitation to the public within the meaning of the Securities and Futures Ordinance (Cap. 571 of the Laws of Hong Kong), or the Securities and Futures Ordinance, (ii) to "professional investors" as defined in the Securities and Futures Ordinance and any rules made thereunder, or (iii) in other circumstances which do not result in the document being a "prospectus" as defined in the Companies (Winding Up and Miscellaneous Provisions) Ordinance, and no advertisement, invitation, or document relating to the shares may be issued or may be in the possession of any person for the purpose of issue (in each case whether in Hong Kong or elsewhere), which is directed at, or the contents of which are likely to be accessed or read by, the public in Hong Kong (except if permitted to do so under the securities laws of Hong Kong) other than with respect to shares which are or are intended to be disposed of only to persons outside Hong Kong or only to "professional investors" in Hong Kong as defined in the Securities and Futures Ordinance and any rules made thereunder.

### ***Singapore***

This prospectus has not been registered as a prospectus with the Monetary Authority of Singapore. Accordingly, this prospectus and any other document or material in connection with the offer or sale, or invitation for subscription or purchase, of the shares may not be circulated or distributed, nor may the shares

be offered or sold, or be made the subject of an invitation for subscription or purchase, whether directly or indirectly, to persons in Singapore other than (i) to an institutional investor (as defined under Section 4A of the Securities and Futures Act, Chapter 289 of Singapore, or the SFA), under Section 274 of the SFA, (ii) to a relevant person (as defined in Section 275(2) of the SFA) pursuant to Section 275(1) of the SFA, or any person pursuant to Section 275(1A) of the SFA, and in accordance with the conditions specified in Section 275 of the SFA, or (iii) otherwise pursuant to, and in accordance with the conditions of, any other applicable provision of the SFA, in each case subject to conditions set forth in the SFA.

Where the shares are subscribed or purchased under Section 275 of the SFA by a relevant person which is a corporation (which is not an accredited investor (as defined in Section 4A of the SFA)) the sole business of which is to hold investments and the entire share capital of which is owned by one or more individuals, each of whom is an accredited investor, the securities (as defined in Section 239(1) of the SFA) of that corporation shall not be transferable for six months after that corporation has acquired the shares under Section 275 of the SFA except: (i) to an institutional investor under Section 274 of the SFA or to a relevant person (as defined in Section 275(2) of the SFA), (ii) where such transfer arises from an offer in that corporation's securities pursuant to Section 275(1A) of the SFA, (iii) where no consideration is or will be given for the transfer, (iv) where the transfer is by operation of law, (v) as specified in Section 276(7) of the SFA, or (vi) as specified in Regulation 32 of the Securities and Futures (Offers of Investments) (Shares and Debentures) Regulations 2005 of Singapore, or Regulation 32.

Where the shares are subscribed or purchased under Section 275 of the SFA by a relevant person which is a trust (where the trustee is not an accredited investor (as defined in Section 4A of the SFA)) whose sole purpose is to hold investments and each beneficiary of the trust is an accredited investor, the beneficiaries' rights and interest (howsoever described) in that trust shall not be transferable for six months after that trust has acquired the shares under Section 275 of the SFA except: (i) to an institutional investor under Section 274 of the SFA or to a relevant person (as defined in Section 275(2) of the SFA), (ii) where such transfer arises from an offer that is made on terms that such rights or interest are acquired at a consideration of not less than \$200,000 (or its equivalent in a foreign currency) for each transaction (whether such amount is to be paid for in cash or by exchange of securities or other assets), (iii) where no consideration is or will be given for the transfer, (iv) where the transfer is by operation of law, (v) as specified in Section 276(7) of the SFA, or (vi) as specified in Regulation 32.

Solely for the purposes of its obligations pursuant to Section 309B of the SFA, we have determined, and hereby notify all relevant persons (as defined in Section 309A of the SFA) that the shares are "prescribed capital markets products" (as defined in the Securities and Futures (Capital Markets Products) Regulations 2018) and Excluded Investment Products (as defined in MAS Notice SFA 04-N12: Notice on the Sale of Investment Products and MAS Notice FAA-N16: Notice on Recommendations on Investment Products).

### ***Japan***

The securities have not been and will not be registered under the Financial Instruments and Exchange Act of Japan (Act No. 25 of 1948, as amended), or the "FIEA." The securities may not be offered or sold, directly or indirectly, in Japan or to or for the benefit of any resident of Japan (including any person resident in Japan or any corporation or other entity organized under the laws of Japan) or to others for reoffering or resale, directly or indirectly, in Japan or to or for the benefit of any resident of Japan, except pursuant to an exemption from the registration requirements of the FIEA and otherwise in compliance with any relevant laws and regulations of Japan.

### ***Switzerland***

The shares may not be publicly offered in Switzerland and will not be listed on the SIX Swiss Exchange ("SIX") or on any other stock exchange or regulated trading facility in Switzerland. This document has been prepared without regard to the disclosure standards for issuance prospectuses under art. 652a or art. 1156 of the Swiss Code of Obligations or the disclosure standards for listing prospectuses under art. 27 ff. of the SIX Listing Rules or the listing rules of any other stock exchange or regulated trading facility in Switzerland. Neither this document nor any other offering or marketing material relating to the shares or the offering may be publicly distributed or otherwise made publicly available in Switzerland.

Neither this document nor any other offering or marketing material relating to the offering, the Company, the shares have been or will be filed with or approved by any Swiss regulatory authority. In particular, this document will not be filed with, and the offer of shares will not be supervised by, the Swiss Financial Market Supervisory Authority FINMA (“FINMA”), and the offer of shares has not been and will not be authorized under the Swiss Federal Act on Collective Investment Schemes (“CISA”). The investor protection afforded to acquirers of interests in collective investment schemes under the CISA does not extend to acquirers of shares.

***Dubai International Financial Centre***

This prospectus relates to an Exempt Offer in accordance with the Offered Securities Rules of the Dubai Financial Services Authority (“DFSA”). This prospectus is intended for distribution only to persons of a type specified in the Offered Securities Rules of the DFSA. It must not be delivered to, or relied on by, any other person. The DFSA has no responsibility for reviewing or verifying any documents in connection with Exempt Offers. The DFSA has not approved this prospectus nor taken steps to verify the information set forth herein and has no responsibility for the prospectus. The shares to which this prospectus relates may be illiquid and/or subject to restrictions on their resale. Prospective purchasers of the shares offered should conduct their own due diligence on the shares. If you do not understand the contents of this prospectus you should consult an authorized financial advisor.

## LEGAL MATTERS

The validity of the shares of Class B common stock will be passed upon for us by Simpson Thacher & Bartlett LLP, New York, New York. Certain legal matters in connection with this offering will be passed upon for the underwriters by Goodwin Procter LLP, Redwood City, California and for the selling stockholders by Whalen LLP, Newport Beach, California.

## EXPERTS

The consolidated financial statements of Bentley Systems, Incorporated as of and for the years ended December 31, 2018 and 2019 have been included herein and in the registration statement in reliance upon the report of KPMG LLP, independent registered public accounting firm, appearing elsewhere herein, and upon the authority of said firm as experts in accounting and auditing. The audit report refers to changes in accounting principle for revenue from contracts with customers and sales commissions due to the adoption of new accounting standards as of January 1, 2019.

## WHERE YOU CAN FIND MORE INFORMATION

We have filed with the SEC a registration statement on Form S-1 under the Securities Act with respect to the shares of Class B common stock covered by this prospectus. This prospectus, which constitutes a part of the registration statement, does not contain all of the information set forth in the registration statement, some of which is contained in exhibits to the registration statement as permitted by the rules and regulations of the SEC. For further information with respect to us and our Class B common stock, we refer you to the registration statement of which this prospectus forms a part, including the exhibits filed as a part of the registration statement. If a contract or document has been filed as an exhibit to the registration statement of which this prospectus forms a part, please see the copy of the contract or document that has been filed. The SEC maintains an Internet website that contains reports, proxy statements and other information about issuers, like us, that file electronically with the SEC. The address of that website is [www.sec.gov](http://www.sec.gov).

Immediately upon the effectiveness of the registration statement of which this prospectus forms a part, we became subject to the information and reporting requirements of the Exchange Act and, in accordance with this law, will file periodic reports, proxy statements, and other information with the SEC. These periodic reports, proxy statements, and other information will be available for inspection and copying at the website of the SEC referred to above. We also maintain a website at [www.bentley.com](http://www.bentley.com). Upon the effectiveness of the registration statement of which this prospectus forms a part, you may access these materials free of charge as soon as reasonably practicable after they are electronically filed with, or furnished to, the SEC. Information contained on our website is not a part of this prospectus and the inclusion of our website address in this prospectus is an inactive textual reference only.

**BENTLEY SYSTEMS, INCORPORATED AND SUBSIDIARIES**  
**INDEX TO CONSOLIDATED FINANCIAL STATEMENTS**

<b>Audited Financial Statements:</b>	<b>Page No.</b>
<a href="#">Report of Independent Registered Public Accounting Firm</a>	<a href="#">F-2</a>
<a href="#">Consolidated Balance Sheets</a>	<a href="#">F-3</a>
<a href="#">Consolidated Statements of Operations</a>	<a href="#">F-4</a>
<a href="#">Consolidated Statements of Comprehensive Income</a>	<a href="#">F-5</a>
<a href="#">Consolidated Statements of Stockholders' Equity</a>	<a href="#">F-6</a>
<a href="#">Consolidated Statements of Cash Flows</a>	<a href="#">F-7</a>
<a href="#">Notes to Consolidated Financial Statements</a>	<a href="#">F-8</a>
<b>Unaudited Interim Financial Statements:</b>	<b>Page No.</b>
<a href="#">Consolidated Balance Sheets</a>	<a href="#">F-45</a>
<a href="#">Consolidated Statements of Operations</a>	<a href="#">F-46</a>
<a href="#">Consolidated Statements of Comprehensive Income</a>	<a href="#">F-47</a>
<a href="#">Consolidated Statements of Stockholders' Equity</a>	<a href="#">F-49</a>
<a href="#">Consolidated Statements of Cash Flows</a>	<a href="#">F-50</a>
<a href="#">Notes to Consolidated Financial Statements</a>	<a href="#">F-51</a>

**Report of Independent Registered Public Accounting Firm**

To the Stockholders and Board of Directors  
Bentley Systems, Incorporated:

*Opinion on the Consolidated Financial Statements*

We have audited the accompanying consolidated balance sheets of Bentley Systems, Incorporated and subsidiaries (the Company) as of December 31, 2019 and 2018, the related consolidated statements of operations, comprehensive income, stockholders' equity, and cash flows for each of the years in the two-year period ended December 31, 2019, and the related notes (collectively, the consolidated financial statements). In our opinion, the consolidated financial statements present fairly, in all material respects, the financial position of the Company as of December 31, 2019 and 2018, and the results of its operations and its cash flows for each of the years in the two-year period ended December 31, 2019, in conformity with U.S. generally accepted accounting principles.

*Change in Accounting Principle*

As discussed in Note 2 to the consolidated financial statements, the Company has changed its method of accounting for revenue from contracts with customers and sales commissions as of January 1, 2019 due to the adoption of Accounting Standards Codification Topic 606, *Revenue from Contracts with Customers*, and Subtopic 340-40, *Other Assets and Deferred Costs — Contracts with Customers*.

*Basis for Opinion*

These consolidated financial statements are the responsibility of the Company's management. Our responsibility is to express an opinion on these consolidated financial statements based on our audits. We are a public accounting firm registered with the Public Company Accounting Oversight Board (United States) (PCAOB) and are required to be independent with respect to the Company in accordance with the U.S. federal securities laws and the applicable rules and regulations of the Securities and Exchange Commission and the PCAOB.

We conducted our audits in accordance with the standards of the PCAOB. Those standards require that we plan and perform the audit to obtain reasonable assurance about whether the consolidated financial statements are free of material misstatement, whether due to error or fraud. Our audits included performing procedures to assess the risks of material misstatement of the consolidated financial statements, whether due to error or fraud, and performing procedures that respond to those risks. Such procedures included examining, on a test basis, evidence regarding the amounts and disclosures in the consolidated financial statements. Our audits also included evaluating the accounting principles used and significant estimates made by management, as well as evaluating the overall presentation of the consolidated financial statements. We believe that our audits provide a reasonable basis for our opinion.

/s/ KPMG LLP

We have served as the Company's auditor since 2002.

Philadelphia, Pennsylvania  
March 6, 2020



## BENTLEY SYSTEMS, INCORPORATED AND SUBSIDIARIES

**Consolidated Balance Sheets**  
(in thousands, except share and per share data)

	December 31,	
	2018	2019
<b>Assets</b>		
Current assets:		
Cash and cash equivalents	\$ 81,183	\$121,101
Accounts receivable, net of allowances of \$7,611 and \$7,274, respectively	184,565	204,501
Prepaid income taxes	5,085	4,543
Prepaid and other current assets	12,390	23,413
<b>Total current assets</b>	<b>283,223</b>	<b>353,558</b>
Property and equipment, net	29,393	29,632
Intangible assets, net	54,001	46,313
Goodwill	446,318	480,065
Investment in joint venture	—	1,725
Deferred income taxes	81,066	51,068
Other assets	29,595	32,238
<b>Total assets</b>	<b>\$ 923,596</b>	<b>\$994,599</b>
<b>Liabilities and Stockholders' Equity</b>		
Current liabilities:		
Accounts payable	\$ 8,567	\$ 17,669
Accruals and other current liabilities	136,699	167,517
Deferred revenues	287,682	204,991
Income taxes payable	2,794	2,236
<b>Total current liabilities</b>	<b>435,742</b>	<b>392,413</b>
Long-term debt	258,750	233,750
Deferred revenues	49,769	8,154
Deferred income taxes	10,470	8,260
Income taxes payable	12,904	8,140
Other liabilities	8,530	9,263
<b>Total liabilities</b>	<b>776,165</b>	<b>659,980</b>
Commitments and contingencies (Note 17)		
Stockholders' equity:		
Class A Common Stock, \$0.01 par value, authorized 320,000,000 shares; issued 11,601,757 shares as of December 31, 2018 and 2019 and Class B Common Stock, \$0.01 par value, authorized 600,000,000 shares; issued 238,681,756 and 243,241,192 shares as of December 31, 2018 and 2019, respectively	2,502	2,548
Additional paid-in capital	392,896	408,667
Accumulated other comprehensive loss	(29,414)	(23,927)
Accumulated deficit	(218,553)	(52,669)
<b>Total stockholders' equity</b>	<b>147,431</b>	<b>334,619</b>
<b>Total liabilities and stockholders' equity</b>	<b>\$ 923,596</b>	<b>\$994,599</b>

See accompanying notes to consolidated financial statements.

## BENTLEY SYSTEMS, INCORPORATED AND SUBSIDIARIES

**Consolidated Statements of Operations**  
(in thousands, except share and per share data)

	Year Ended December 31,	
	2018	2019
<b>Revenues:</b>		
Subscriptions	\$ 557,421	\$ 608,300
Perpetual licenses	61,065	59,693
Subscriptions and licenses	618,486	667,993
Services	73,224	68,661
Total revenues	691,710	736,654
<b>Cost of revenues:</b>		
Cost of subscriptions and licenses	55,113	71,578
Cost of services	76,211	72,572
Total cost of revenues	131,324	144,150
Gross profit	560,386	592,504
<b>Operating expenses:</b>		
Research and development	175,032	183,552
Selling and marketing	160,635	155,294
General and administrative	89,328	97,580
Amortization of purchased intangibles	14,000	14,213
Total operating expenses	438,995	450,639
Income from operations	121,391	141,865
Interest expense, net	(8,765)	(8,199)
Other income (expense), net	236	(5,557)
Income before income taxes	112,862	128,109
Provision for income taxes	(29,250)	23,738
Equity in loss of joint venture, net of tax	—	1,275
Net income	142,112	103,096
Less: Net income attributable to participating securities	(4)	(8)
Net income attributable to Class A and Class B common stockholders	\$ 142,108	\$ 103,088
<b>Per share information:</b>		
Net income per share, basic	\$ 0.50	\$ 0.36
Net income per share, diluted	\$ 0.49	\$ 0.35
Weighted average shares outstanding, basic	285,805,096	284,625,642
Weighted average shares outstanding, diluted	292,624,496	293,796,707

See accompanying notes to consolidated financial statements.

**BENTLEY SYSTEMS, INCORPORATED AND SUBSIDIARIES****Consolidated Statements of Comprehensive Income**  
**(in thousands, except share and per share data)**

	Year Ended December 31,	
	2018	2019
Net income	\$ 142,112	\$ 103,096
Other comprehensive income (loss), net of taxes:		
Foreign currency translation adjustments	(11,020)	5,959
Actuarial gain (loss) on retirement plan, net of tax effect of (\$62) and \$203	146	(472)
Total other comprehensive income (loss), net of taxes	(10,874)	5,487
Comprehensive income	<u>\$ 131,238</u>	<u>\$ 108,583</u>

See accompanying notes to consolidated financial statements.

## BENTLEY SYSTEMS, INCORPORATED AND SUBSIDIARIES

Consolidated Statements of Stockholders' Equity  
(in thousands, except share and per share data)

	Stockholders' Equity					
	Class A and Class B Common Stock		Additional paid-in capital	Accumulated other comprehensive loss	Accumulated deficit	Total stockholders' equity
	Shares	Par value				
Balance as of December 31, 2017	247,465,176	\$2,474	\$ 377,809	\$ (18,540)	\$ (309,576)	\$ 52,167
Net income	—	—	—	—	142,112	142,112
Other comprehensive income (loss)	—	—	—	(10,874)	—	(10,874)
Dividends declared	—	—	—	—	(20,005)	(20,005)
Profit sharing plan shares, net	(465,979)	(5)	—	—	(3,382)	(3,387)
Shares issued in connection with deferred compensation plan	2,332,585	23	—	—	(6,884)	(6,861)
Deferred compensation plan voluntary contributions and vesting of awards	—	—	4,504	—	—	4,504
Payment of shareholder Put and Call rights	(1,131,928)	(11)	—	—	(8,560)	(8,571)
Common Stock Purchase Agreement, net	(1,281,633)	(13)	13	—	(9,673)	(9,673)
Stock option exercises, net	2,812,998	28	2,151	—	(1,569)	610
Stock-based compensation expense	—	—	7,882	—	—	7,882
Shares related to restricted stock, net	546,783	6	494	—	(637)	(137)
Other	5,511	—	43	—	—	43
Cumulative effect adjustment on deferred tax expense	—	—	—	—	(379)	(379)
Balance as of December 31, 2018	250,283,513	2,502	392,896	(29,414)	(218,553)	147,431
Cumulative effect of accounting changes	—	—	—	—	107,822	107,822
Net income	—	—	—	—	103,096	103,096
Other comprehensive income (loss)	—	—	—	5,487	—	5,487
Dividends declared	—	—	—	—	(25,390)	(25,390)
Profit sharing plan shares, net	(318,203)	(3)	—	—	(2,414)	(2,417)
Shares issued in connection with deferred compensation plan	2,322,983	23	—	—	(5,632)	(5,609)
Deferred compensation plan voluntary contributions and vesting of awards	—	—	3,586	—	—	3,586
Payment of shareholder Put and Call rights	(1,126,747)	(11)	—	—	(8,827)	(8,838)
Common Stock Purchase Agreement, net	64,509	—	466	—	(48)	418
Stock option exercises, net	3,214,542	33	3,579	—	(2,309)	1,303
Stock-based compensation expense	—	—	8,091	—	—	8,091
Shares related to restricted stock, net	395,336	4	(4)	—	(399)	(399)
Other	7,016	—	53	—	(15)	38
Balance as of December 31, 2019	254,842,949	\$2,548	\$ 408,667	\$ (23,927)	\$ (52,669)	\$ 334,619

See accompanying notes to consolidated financial statements.

## BENTLEY SYSTEMS, INCORPORATED AND SUBSIDIARIES

**Consolidated Statements of Cash Flows**  
(in thousands, except share and per share data)

	Year Ended December 31,	
	2018	2019
Cash flows from operating activities:		
Net income	\$ 142,112	\$ 103,096
Adjustments to reconcile net income to net cash provided by operating activities:		
Depreciation and amortization	29,200	32,160
Provision for accounts receivable allowance	2,393	862
Deferred income taxes	(60,060)	732
Deferred compensation plan activity	4,323	3,994
Stock-based compensation expense	7,882	8,091
Amortization of deferred debt issuance costs	552	553
Decrease in fair value of call options	487	159
Change in fair value of contingent consideration	272	62
Foreign currency remeasurement loss (gain)	(1,645)	5,311
Equity in loss of joint venture, net of tax	—	1,275
Changes in assets and liabilities, net of effect from acquisitions:		
Accounts receivable, net	(41,787)	(21,152)
Prepaid and other assets	2,831	(668)
Accounts payable, accruals and other liabilities	37,249	41,880
Deferred revenues	21,247	(268)
Income taxes payable	16,409	(5,314)
Net cash provided by operating activities	<u>161,465</u>	<u>170,773</u>
Cash flows from investing activities:		
Purchases of property and equipment and investment in capitalized software	(18,616)	(15,804)
Capitalization of costs to translate software products into foreign languages	(877)	(835)
Acquisitions, net of cash acquired of \$7,774 and \$2,523, respectively	(135,264)	(34,054)
Investment in joint venture	—	(3,000)
Net cash used in investing activities	<u>(154,757)</u>	<u>(53,693)</u>
Cash flows from financing activities:		
Proceeds from credit facilities	148,250	191,250
Payments of credit facilities	(159,500)	(216,250)
Payments of acquisition debt and other consideration	9	(11,029)
Payments of dividends	(20,059)	(24,989)
Payments for shares acquired including shares withheld for taxes	(46,451)	(24,166)
Proceeds from Common Stock Purchase Agreement	16,220	4,510
Net proceeds from exercise of common stock options and restricted stock	2,732	3,626
Net cash used in financing activities	<u>(58,799)</u>	<u>(77,048)</u>
Effect of exchange rate changes on cash and cash equivalents	(1,193)	(114)
Increase (decrease) in cash and cash equivalents	<u>(53,284)</u>	<u>39,918</u>
Cash and cash equivalents, beginning of year	134,467	81,183
Cash and cash equivalents, end of year	<u>\$ 81,183</u>	<u>\$ 121,101</u>
Supplemental information:		
Cash paid for income taxes	\$ 25,782	\$ 27,907
Income tax refunds	7,285	1,752
Interest paid	8,863	9,221
Non-cash contingent acquisition consideration	13,456	4,498
Non-cash deferred acquisition consideration	690	—

See accompanying notes to consolidated financial statements.

**BENTLEY SYSTEMS, INCORPORATED AND SUBSIDIARIES****Notes to Consolidated Financial Statements  
(in thousands, except share and per share data)****Note 1: Basis of Presentation and Significant Accounting Policies**

**Description of Business and Operations**— Bentley Systems, Incorporated (“Bentley” or the “Company”) is a Delaware corporation that was founded in 1984 and is headquartered in Exton, Pennsylvania. The Company, together with its subsidiaries, is a leading global provider of infrastructure engineering software solutions for professionals and organizations involved in the project delivery and operational performance of infrastructure assets. The Company is dedicated to advancing infrastructure through its comprehensive software solutions that span engineering disciplines, assets, and lifecycle processes. The Company’s integrated software platform encompasses both the design and construction of infrastructure, which the Company refers to as project delivery, and the operation of infrastructure assets, which the Company refers to as asset performance. The Company’s software solutions are designed to enable information mobility for a more complete flow of information among applications, across distributed project teams, from offices to the field, and throughout the infrastructure lifecycle. The Company believes its solutions extend the reach and scope of digital engineering models from the project delivery phase into the asset performance phase of the infrastructure lifecycle, which enables engineers to make infrastructure assets more intelligent and sustainable. Users of the Company’s solutions include engineers and construction professionals who collaborate on project delivery, and owner-operators who maintain, adapt, and optimize the performance of infrastructure assets.

**Basis of Presentation and Consolidation**— The consolidated financial statements and accompanying notes have been prepared in United States (“U.S.”) dollars and in accordance with accounting principles generally accepted in the United States of America (“U.S. GAAP”). The accompanying consolidated financial statements include the accounts of the Company and its wholly-owned subsidiaries. All significant intercompany accounts and transactions have been eliminated in consolidation.

The Company’s principal subsidiaries are Bentley Systems International Limited (Ireland), Bentley Software International, Limited (Bermuda), Bentley Canada Inc. (Canada), Bentley Systems Europe BV (the Netherlands), Bentley Systems Pty Ltd. (Australia), Bentley Systems Co., Ltd. (Japan), Bentley Systems Germany GmbH (Germany), Bentley Systems Ltd. (UK), and Bentley Systems India Private Limited (India).

**Stock Dividend**— On May 1, 2018, the Company paid a previously declared stock dividend (the “Dividend”) to all holders of the Company’s common stock as of April 30, 2018. Under the terms of the Dividend, each stockholder received one share of the Company’s Class B Common Stock for each share of either Class A or Class B Common Stock then owned, including shares held in the Company’s 401(k)/Profit Sharing plan. Because the Dividend had the economic effect of a 2-for-1 stock split (with twice as many shares issued, each worth half the original value of a share), all prior period share and per share amounts presented in the consolidated financial statements and notes have been adjusted on a retroactive basis to give effect to the Dividend.

In addition, under the terms of the Company’s equity incentive plans and instruments, all outstanding awards and instruments were automatically adjusted as required by their terms to reflect the Dividend, including, as it relates to stock options, by doubling the number of outstanding options and reducing by one-half the exercise prices of all outstanding options.

**Use of Estimates**— The preparation of consolidated financial statements and related disclosures in conformity with U.S. GAAP requires management to make estimates and assumptions that affect the reported amounts of assets and liabilities and disclosure of contingent assets and liabilities at the dates of the financial statements and the reported amounts of revenues and expenses during the reporting periods. The Company’s critical estimates and assumptions include revenue recognition, adequacy of allowance for accounts receivable, determination of the fair value of acquired assets and liabilities, the fair value of derivative financial instruments, the fair value of stock-based compensation, useful lives for depreciation and amortization, impairment of goodwill and intangible assets, and accounting for income taxes. Actual results could differ materially from these estimates.

## BENTLEY SYSTEMS, INCORPORATED AND SUBSIDIARIES

Notes to Consolidated Financial Statements (Continued)  
(in thousands, except share and per share data)

## Note 1: Basis of Presentation and Significant Accounting Policies (Continued)

**Reclassifications**—Certain prior year amounts have been reclassified for consistency with the current period presentation. These reclassifications had no effect on the reported results of operations.

**Cash and Cash Equivalents**—The Company considers all highly liquid investments with a maturity of three months or less at the date of purchase to be cash equivalents. At December 31, 2018 and 2019, all of the Company's cash and cash equivalents consisted of money market funds and cash held in checking accounts maintained at various financial institutions. Cash equivalents are recorded at cost, which approximates fair value.

**Revenues**—On January 1, 2019, the Company adopted Accounting Standards Update (“ASU”) No. 2014-09, *Revenue from Contracts with Customers*, and related amendments (“Topic 606”) as discussed further in Recently Adopted Accounting Guidance below. Results for reporting periods beginning on or after January 1, 2019 are presented under Topic 606, while prior period amounts are not adjusted and continue to be reported in accordance with the guidance provided by Accounting Standards Codification (“ASC”) 985-605, *Software-Revenue Recognition*, and revenues for non-software deliverables in accordance with Topic 605-25, *Revenue Recognition, Multiple-Element Arrangements*. The Company refers to ASC 985-605 and Topic 605-25 collectively as Topic 605.

The accounting policies for the Company's revenue recognition are explained in Note 3, Revenue from Contracts with Customers.

**Cost of Revenues**—Cost of subscriptions and licenses includes salaries and other related costs, including the depreciation of property and equipment and the amortization of capitalized software costs associated with servicing software subscriptions, the amortization of intangible assets associated with acquired software and technology, channel partner compensation for providing sales coverage to subscribers, as well as cloud-related costs incurred for servicing our customers using cloud deployed hosted solutions and those using our SELECT program. Cost of services includes salaries for internal and third-party personnel and related overhead costs, including depreciation of property and equipment, for providing training, implementation, configuration, and customization services to customers, amortization of capitalized software costs, and related out-of-pocket expenses incurred.

**Property and Equipment**—Property and equipment are recorded at cost less accumulated depreciation. Depreciation is calculated using the straight-line method over the estimated useful lives of the assets, which range from three to twenty-five years. Leasehold improvements are depreciated over the shorter of the estimated useful life of the leasehold improvements or the lease term. Land is not depreciated. Depreciation for equipment commences once it is placed in service and depreciation for buildings and leasehold improvements commences once they are ready for their intended use. Estimated useful lives of property and equipment are as follows:

	<u>Useful life</u>
Building and improvements	25 years
Computer equipment and software	3 years
Furniture, fixtures, and equipment	5 years
Aircraft	6 years
Automobiles	3 years

Cost of maintenance and repairs is charged to expense as incurred. Upon retirement or other disposition, the cost of the asset and the related accumulated depreciation are removed from the accounts and any resulting gain or loss is reflected in the consolidated statements of operations.

**BENTLEY SYSTEMS, INCORPORATED AND SUBSIDIARIES****Notes to Consolidated Financial Statements (Continued)**  
**(in thousands, except share and per share data)****Note 1: Basis of Presentation and Significant Accounting Policies (Continued)**

**Goodwill and Other Intangibles**—Intangible assets arise from acquisitions and principally consist of goodwill, trademarks, customer relationships, in-process research and development, and acquired software and technology. Intangibles, other than goodwill and in-process research and development, are amortized on a straight-line basis over their estimated useful lives, which range from three to ten years (see Note 6).

Goodwill consists of the excess of cost over the fair value of net assets acquired in business combinations. Goodwill is not amortized, but instead is tested annually for impairment, or more frequently if events occur or circumstances change that would more likely than not reduce its fair value below its carrying amount. The Company operates as a single reporting unit.

The initial step in evaluating goodwill for impairment requires the Company to determine the reporting unit's fair value and compare it to the carrying value, including goodwill, of such reporting unit. As part of the assessment, the Company may first qualitatively assess whether it is more likely than not (a likelihood of more than 50 percent) that a goodwill impairment exists. In evaluating whether it is more likely than not that a goodwill impairment exists, the Company considers the factors identified in ASC 350, *Intangibles — Goodwill and Other*. The Company also considers whether there are significant differences between the carrying amount and the estimated fair value of its assets and liabilities, and the existence of significant unrecognized intangible assets. Based upon the Company's most recent annual impairment assessment completed as of October 1, 2019, it is not more likely than not that a goodwill impairment exists. There was no impairment of goodwill as a result of the Company's annual impairment assessments conducted during the years ended December 31, 2018 or 2019.

**Long-Lived Assets**—The Company evaluates the recoverability of long-lived assets, such as property and equipment and amortizable intangible assets, in accordance with authoritative guidance on accounting for the impairment or disposal of long-lived assets, which includes evaluating long-lived assets for impairment whenever events or changes in circumstances indicate that the carrying value of these assets may not be recoverable. If circumstances require a long-lived asset to be tested for possible impairment, the Company first compares the undiscounted cash flows expected to be generated by that asset to its carrying value. If the carrying value of the long-lived asset is not recoverable on an undiscounted cash flow basis, an impairment is recognized to the extent that the carrying value exceeds its fair value. No impairment of long-lived assets occurred during the years ended December 31, 2018 or 2019.

**Research and Development**—Research and development expenses, which are generally expensed as incurred, primarily consist of personnel and related costs of our research and development staff, including salaries, benefits, bonuses, stock-based compensation, and costs of certain third-party contractors, as well as allocated overhead costs. The Company expenses software development costs, including costs to develop software products or the software component of products to be sold, leased, or marketed to external accounts, before technological feasibility is reached. Technological feasibility is typically reached shortly before the release of such products and as a result, development costs that meet the criteria for capitalization were not material for the periods presented.

The Company capitalizes certain development costs related to certain projects under its Accelerated Commercial Development Program (the Company's structured approach to an in-house business incubator function) once technological feasibility is established. Technological feasibility is established when a detailed program design has been completed and documented, the Company has established that the necessary skills, hardware, and software technology are available to produce the product, and there are no unresolved high-risk development issues. Once the software is ready for its intended use, amortization is recorded over the software's estimated useful life (generally three years). During the years ended December 31, 2018 and 2019, total costs capitalized under the Accelerated Commercial Development Program were \$5,735 and \$6,060, respectively. Additionally, during the years ended December 31, 2018 and 2019, total



## BENTLEY SYSTEMS, INCORPORATED AND SUBSIDIARIES

Notes to Consolidated Financial Statements (Continued)  
(in thousands, except share and per share data)**Note 1: Basis of Presentation and Significant Accounting Policies (Continued)**

Accelerated Commercial Development Program related amortization recorded in *Costs of subscriptions and licenses* was \$2,052 and \$3,516, respectively.

Certain costs related to the creation of foreign language translations are capitalized and amortized over the economic life of the software.

**Advertising Expense**—The Company expenses advertising costs as incurred. Advertising expense of \$2,378 and \$1,579 is included in *Selling and marketing* expense in the accompanying consolidated statements of operations for the years ended December 31, 2018 and 2019, respectively.

**Income Taxes**—The Company recognizes deferred income tax assets and liabilities for the expected future tax consequences of net operating loss carryforwards, credit carryforwards, and temporary differences between financial statement carrying amounts of assets and liabilities and their respective tax bases, using enacted tax rates in effect for the year in which the items are expected to reverse.

The Company accounts for uncertain tax positions based on an evaluation as to whether it is more likely than not that a tax position will be sustained on audit, including resolution of any related appeals or litigation processes. This evaluation is based on all available evidence and assumes that the appropriate tax authorities have full knowledge of all relevant information concerning the tax position. The tax benefit recognized is based on the largest amount that is greater than 50% likely of being realized upon ultimate settlement. Interest expense and penalties are included in *Provision for income taxes* in the consolidated statements of operations.

**U.S. Tax Reform**—On December 22, 2017, the Tax Cuts and Jobs Act (the “Act” or “U.S. tax reform”) was enacted. U.S. tax reform, among other things, reduces the U.S. federal income tax rate to 21% from 35% in 2018, institutes a dividends received deduction for foreign earnings with a related tax for the deemed repatriation of unremitted foreign earnings, and creates a new U.S. minimum tax on earnings of foreign subsidiaries. The Company has completed its accounting for the effects of the Act in 2018 and has included those effects in *Provision for income taxes* in the consolidated statements of operations.

**Segment**—Operating segments are defined as components of an enterprise about which separate financial information is evaluated regularly by the chief operating decision maker (“CODM”) to allocate resources and assess performance. The Company defines its CODM to be its chief executive officer. The chief executive officer reviews the financial information presented on a consolidated basis for purposes of making operating decisions, allocating resources, and evaluating the Company’s financial performance. Accordingly, the Company has determined it operates and manages its business in a single reportable operating segment, the development and marketing of computer software and related services. The Company markets its products and services through the Company’s offices in the United States and its wholly-owned branches and subsidiaries internationally.

**Foreign Currency Translation**—Gains and losses resulting from foreign currency transactions denominated in currencies other than the functional currency are included in *Other income (expense), net* (see Note 20). The assets and liabilities of foreign subsidiaries are translated from their respective functional currencies into U.S. Dollars at the rates in effect at the balance sheet date, and revenue and expense amounts are translated at average rates during the period. Foreign currency translation adjustments are recorded as a component of *Other comprehensive income (loss), net of taxes* in the consolidated statements of comprehensive income.

**Concentration of Credit Risk**—Financial instruments that potentially subject the Company to concentration of credit risk consist primarily of its cash and cash equivalents and receivables. To reduce credit risk, the Company performs ongoing credit evaluations of its customers and limits the amount of credit extended when deemed necessary. Generally, the Company requires no collateral from its customers. The

## BENTLEY SYSTEMS, INCORPORATED AND SUBSIDIARIES

Notes to Consolidated Financial Statements (Continued)  
(in thousands, except share and per share data)**Note 1: Basis of Presentation and Significant Accounting Policies (Continued)**

Company maintains an allowance for potential credit losses, but historically has not experienced any significant losses related to individual customers or groups of customers in any particular industry or geographic area. No single customer accounted for more than 2.5% of the Company's revenue in the years ended December 31, 2018 or 2019.

The Company's cash and cash equivalents are deposited with financial institutions and invested in money market funds that the Company believes are of high credit quality.

**Investment in Joint Venture**— The Company is party to a joint venture which is accounted for using the equity method. The Company applies the equity method to investments in which its ownership interest is 50 percent or less and in which it exercises significant influence over operating and financial policies of the investee. Under the equity method, original investments are recorded at cost and adjusted by the Company's share of undistributed earnings and losses of these investments. The joint venture is not material to the Company's financial results (see Note 7).

**Accounts Receivable and Allowance for Doubtful Accounts**— Accounts receivable represent receivables from customers for products and services invoiced by the Company for which payment is outstanding. Receivables are recorded at the invoiced amount and do not bear interest.

The Company establishes an allowance for doubtful accounts for estimated losses expected during the accounts receivable collection process. The allowance for doubtful accounts reduces the accounts receivable balance to the net realizable value of the outstanding accounts and installment receivables. The development of the allowance for doubtful accounts is based on a review of past due amounts, historical write-off and recovery experience, as well as aging trends affecting specific accounts and general operational factors affecting all accounts. Account balances are charged off against the allowance after all means of collection have been exhausted and the potential for recovery is considered remote.

The Company considers current economic trends when evaluating the adequacy of the allowance for doubtful accounts. If circumstances relating to specific customers change or unanticipated changes occur in the general business environment, the Company's estimate of the recoverability of receivables could be further adjusted.

Activity related to the Company's allowance for doubtful accounts was as follows:

	Year Ended December 31,	
	2018	2019
Balance, beginning of year	\$5,669	\$7,611
Allowances (recoveries) recorded	1,620	(452)
Foreign currency translation adjustments	322	115
Balance, end of year	<u>\$7,611</u>	<u>\$7,274</u>

**Stock-Based Compensation**— The Company records all stock-based compensation as an expense in the consolidated statements of operations measured at the grant date fair value of the award. The fair value of stock option awards is determined using the Black-Scholes option pricing model. For all other equity-based arrangements, the share-based compensation expense is based on the share price at the grant date (see Note 14).

**Guarantees**— The Company's software license agreements typically provide for indemnification of customers for intellectual property infringement claims. The Company also warrants to customers, when requested, that its software products operate substantially in accordance with standard specifications for a

**BENTLEY SYSTEMS, INCORPORATED AND SUBSIDIARIES****Notes to Consolidated Financial Statements (Continued)**  
**(in thousands, except share and per share data)****Note 1: Basis of Presentation and Significant Accounting Policies (Continued)**

limited period of time. The Company has not incurred significant obligations under customer indemnification or warranty provisions historically and does not expect to incur significant obligations in the future. Accordingly, the Company does not maintain accruals for potential customer indemnification or warranty-related obligations.

**Derivative Arrangements**— The Company records derivative instruments as an asset or liability measured at fair value and depending on the nature of the hedge, the corresponding changes in the fair value of these instruments are recorded in the consolidated statements of operations or comprehensive income. If the derivative is determined to be a hedge, changes in the fair value of the derivative are offset against the change in the fair value of the hedged assets or liabilities through the consolidated statements of operations or recognized in *Other comprehensive income (loss), net of taxes* until the hedged item is recognized in the consolidated statements of operations. The ineffective portion of a derivative's change in fair value is recognized in earnings. Also, changes in the entire fair value of a derivative that is not designated as a hedge are recognized in earnings (see Note 16).

**Fair Value Measurements**— The Company categorizes its assets and liabilities measured at fair value into a three-level hierarchy, based on the priority of the inputs to the respective valuation technique. The fair value hierarchy gives the highest priority to quoted prices in active markets for identical assets or liabilities (Level 1) and the lowest priority to unobservable inputs (Level 3). An asset or liability's classification within the fair value hierarchy is based on the lowest level of significant input to its valuation. The Company's assessment of the significance of a particular input to the fair value measurement requires judgment and may affect the valuation of fair value assets and liabilities and their placement within the fair value hierarchy levels (see Note 16).

**Note 2: Recent Accounting Pronouncements**

In August 2018, the Financial Accounting Standards Board ("FASB") issued ASU No. 2018-15, *Intangibles—Goodwill and Other—Internal-Use Software (Subtopic 350-40): Customer's Accounting for Implementation Costs Incurred in a Cloud Computing Arrangement That is a Service Contract*, which clarifies the accounting for implementation costs in cloud computing arrangements. ASU 2018-15 is effective for the Company for the annual reporting period beginning after December 15, 2020, and interim periods beginning after December 15, 2021. Early adoption is permitted, including adoption in an interim period. The Company is currently evaluating the accounting, transition, and disclosure requirements of the standard and its impact on the Company's consolidated results of operations and financial position.

In August 2018, the FASB issued ASU No. 2018-13, *Fair Value Measurement (Topic 820): Disclosure Framework—Changes to the Disclosure Requirements for Fair Value Measurement*. ASU 2018-13 modifies certain required disclosures and establishes new requirements related to fair value measurement. Additionally, the disclosure requirement to state the reasons for transfers between Level 1 and Level 2, the policy for timing transfers between levels, and the valuation process for Level 3 measurements have been removed. The ASU is effective for the Company for the annual period beginning after December 15, 2019, including interim periods within that annual period. Early adoption is permitted. The Company does not believe the adoption of this guidance will have a material impact on the Company's consolidated results of operations and financial position.

In January 2017, the FASB issued ASU No. 2017-04, *Intangibles-Goodwill and Other (Topic 350): Simplifying the Test for Goodwill Impairment*, which removes Step 2 of the goodwill impairment test. A goodwill impairment will now be calculated as the amount by which a reporting unit's carrying value exceeds its fair value, not to exceed the carrying amount of goodwill. This ASU is effective for the Company for the interim and annual reporting periods beginning after December 15, 2021. Early adoption is permitted,

**BENTLEY SYSTEMS, INCORPORATED AND SUBSIDIARIES**

**Notes to Consolidated Financial Statements (Continued)**  
**(in thousands, except share and per share data)**

**Note 2: Recent Accounting Pronouncements (Continued)**

including adoption in an interim period. The Company does not believe that this ASU will have a material impact on the Company's consolidated results of operations and financial position.

In June 2016, the FASB issued ASU No. 2016-13, Financial Instruments — Credit Losses (Topic 326): *Measurement of Credit Losses on Financial Instruments*. Current guidance requires the allowance for doubtful accounts to be estimated based on an incurred loss model, which considers past and current conditions. ASU 2016-13 requires companies to use an expected loss model that also considers reasonable and supportable forecasts of future conditions. ASU 2016-13 is effective for the Company for the annual period beginning after December 15, 2020, including interim periods within that annual period. Early adoption is permitted. The Company plans to adopt ASU 2016-13 as of January 1, 2020 and does not believe the adoption of this guidance will have a material impact on the Company's consolidated results of operations and financial position.

In February 2016, the FASB issued ASU No. 2016-02 regarding ASC Topic 842, *Leases* ("Topic 842"). This ASU requires balance sheet recognition of lease assets and lease liabilities by lessees for leases classified as operating leases, with an optional policy election to not recognize lease assets and lease liabilities for leases with a term of 12 months or less. The amendments also require new disclosures, including qualitative and quantitative requirements, providing additional information about the amounts recorded in the financial statements. The new standard is effective for the Company for the fiscal year beginning after December 15, 2020, including interim periods within the fiscal year beginning after December 15, 2020. Early adoption is permitted. Subsequent to the issuance of ASU 2016-02, the FASB issued ASU Nos. 2018-01, *Land Easement Practical Expedient for Transition to Topic 842*, 2018-10, *Codification Improvements to Topic 842, Leases*, 2018-11, *Leases (Topic 842): Targeted Improvements*, and 2018-20, *Narrow-Scope Improvements for Lessors*. These ASUs do not change the core principle of the guidance in ASU 2016-02. Instead, these amendments are intended to clarify and improve operability of certain topics included within the lease standard. These ASUs will have the same effective date and transition requirements as ASU 2016-02.

The Company will adopt Topic 842 as of January 1, 2020 using the modified retrospective method for all existing leases. Upon adoption, the Company is required to recognize its lease assets and its lease liabilities measured by taking the present value of all future fixed lease payments discounted using the Company's incremental borrowing rate.

The Company has elected to opt for the package of practical expedients and to not reassess whether any existing contracts are leases or contain a lease, the lease classification of existing leases, and initial direct costs for existing leases. Additionally, the Company has elected the practical expedients to combine lease and non-lease components for new leases post adoption and to not recognize lease assets and lease liabilities for leases with a term of 12 months or less.

The adoption of Topic 842 will materially increase the Company's total assets and total liabilities as compared to amounts reported prior to adoption. Upon adoption, the Company expects to recognize right of use assets of approximately \$46,000 and lease liabilities of approximately \$48,000 calculated based on the present value of the remaining minimum lease payments as of the adoption date. Topic 842 is not expected to have a material impact to the Company's consolidated statement of operations.

**Recently Adopted Accounting Guidance**

**ASU 2016-15**— In August 2016, the FASB issued ASU No. 2016-15, Statement of Cash Flows (Topic 230): *Classification of Certain Cash Receipts and Cash Payments*. ASU 2016-15 addresses eight specific cash flow issues with the objective of reducing diversity in how certain cash receipts and cash payments are presented and classified in the statement of cash flows. The Company adopted the standard effective

**BENTLEY SYSTEMS, INCORPORATED AND SUBSIDIARIES****Notes to Consolidated Financial Statements (Continued)**  
**(in thousands, except share and per share data)****Note 2: Recent Accounting Pronouncements (Continued)**

January 1, 2019. The adoption of this ASU did not have a material impact on the Company's consolidated statements of cash flows.

**ASU 2016-16**—In October 2016, the FASB issued ASU No. 2016-16, *Income Taxes (Topic 740): Intra-Entity Transfer of Assets Other than Inventory*, which requires the recognition of the income tax effects of an intra-entity transfer of an asset, other than inventory, when the transfer occurs, eliminating an exception under previous U.S. GAAP in which the tax effects of intra-entity asset transfers were deferred until the transferred asset is sold to a third party or otherwise recovered through use. The Company adopted this standard effective January 1, 2018 by applying the required modified retrospective approach with a cumulative-effect adjustment to retained earnings of certain previously deferred tax benefits. Accordingly, a cumulative-effect adjustment on deferred tax expense of \$379 was recorded in *Accumulated deficit* during the year ended December 31, 2018.

During 2018, the Company had intercompany sales of certain intangible operating assets between its foreign subsidiaries. The sales resulted in a 2018 net tax benefit of \$46,369. For the year ended December 31, 2018, the impact of adopting ASU 2016-16 resulted in a reduction of \$45,596 in *Provision of income taxes*, as well as a \$45,596 increase in *Deferred income taxes* (asset) and *Net income*, compared to what the Company would have recognized under previous U.S. GAAP. Furthermore, the impact of adoption resulted in a \$0.16 increase in both basic and diluted earnings per share for the year ended December 31, 2018.

**Revenue Recognition**—On January 1, 2019, the Company adopted Topic 606, which supersedes substantially all existing revenue recognition guidance under U.S. GAAP. The Company adopted Topic 606 using the modified retrospective method, under which the cumulative effect of initially applying Topic 606 of \$125,464 (\$101,489, net of tax) was recorded as a cumulative decrease to the opening balance of *Accumulated deficit* as of January 1, 2019. The Company applied the standard only to contracts that were not completed as of the date of initial application. The comparative information has not been adjusted and continues to be reported under Topic 605.

The core principle of Topic 606 is to recognize revenue when promised goods or services are transferred to a customer in an amount that reflects the consideration that is expected to be received for those goods or services. Under the new guidance, the Company is required to evaluate revenue recognition through a five-step process: (1) identify a contract with a customer; (2) identify the performance obligations in the contract; (3) determine the transaction price; (4) allocate the transaction price to the performance obligations in the contract; and (5) recognize revenue when (or as) the Company satisfies a performance obligation. The standard also requires disclosure of the nature, amount, timing, and uncertainty of revenue and cash flows arising from contracts with customers. In applying the principles of Topic 606, more judgment and estimates are required within the revenue recognition process than was required under previous U.S. GAAP, including identifying performance obligations, estimating the amount of variable consideration to include in the transaction price, and estimating the value of each performance obligation to allocate the total transaction price to each separate performance obligation.

The most significant impact to the Company resulting from the adoption of Topic 606 relates to timing of revenue recognition for perpetual licenses and the accounting for certain of the Company's subscription arrangements that include term-based software licenses bundled with support. Under prior guidance, revenue for perpetual licenses was recognized ratably over a three-year period, while revenue attributable to the term-based software licenses was recognized ratably over the term. Under Topic 606, both perpetual license and term-based software license revenue will be recognized up-front upon delivery of the software license. Revenue recognition related to support, hosting, usage-based offerings, and services is substantially unchanged, with support and hosting revenue recorded ratably over the contract term, usage-based revenue recognized upon usage or delivery, and services revenue as delivered.

## BENTLEY SYSTEMS, INCORPORATED AND SUBSIDIARIES

Notes to Consolidated Financial Statements (Continued)  
(in thousands, except share and per share data)

## Note 2: Recent Accounting Pronouncements (Continued)

**Costs to Obtain a Contract with a Customer**—With the adoption of Topic 606, the Company also adopted ASC Topic 340-40, *Other Assets and Deferred Costs-Contracts with Customers* (Topic 340-40). Prior to the adoption of Topic 340-40, the Company previously recognized compensation paid to sales employees and certain channel partners related to obtaining customer contracts when incurred. Under Topic 340-40, the Company recognizes an asset for the incremental costs of obtaining a contract with a customer if the Company expects the benefit of those costs to be longer than one year. The contract costs are amortized based on the economic life of the goods and services to which the contract costs relate. The Company has determined that certain sales incentive programs meet the requirements to be capitalized. The Company applies a practical expedient to expense costs as incurred for costs to obtain a contract with a customer when the amortization period would have been one year or less. These costs include the Company's internal sales force compensation program and certain channel partner sales incentive programs for which the annual compensation is commensurate with annual sales activities. Under the modified retrospective method, the Company recorded a cumulative decrease of \$7,734 (\$6,333, net of tax) to the opening balance of *Accumulated deficit* as of January 1, 2019. The comparative information has not been adjusted and continues to be reported as incurred.

**Quantitative Effect of Topics 606 and 340-40 Adoption**

The following tables compare the reported consolidated balance sheet and statements of operations, as of and for the year ended December 31, 2019, to the amounts had Topic 605 been in effect.

	As of December 31,			
	2018	2019		
	As reported Topic 605	As adjusted Topic 605	Impact from the adoption of Topic 606 and Topic 340-40	As reported Topic 606
<b>Assets</b>				
Current assets				
Cash and cash equivalents	\$ 81,183	\$ 121,101	\$ —	\$ 121,101
Accounts receivable, net	184,565	204,268	233	204,501
Prepaid income taxes	5,085	6,732	(2,189)	4,543
Prepaid and other current assets <sup>(1)</sup>	12,390	20,080	3,333	23,413
Total current assets	283,223	352,181	1,377	353,558
Property and equipment, net	29,393	29,632	—	29,632
Intangible assets, net	54,001	46,313	—	46,313
Goodwill	446,318	480,065	—	480,065
Investment in joint venture	—	1,725	—	1,725
Deferred income taxes	81,066	72,611	(21,543)	51,068
Other assets <sup>(1)</sup>	29,595	26,517	5,721	32,238
Total assets	\$ 923,596	\$ 1,009,044	\$ (14,445)	\$ 994,599
<b>Liabilities and Stockholders' Equity</b>				
Current liabilities				
Accounts payable	\$ 8,567	\$ 17,669	\$ —	\$ 17,669
Accruals and other current liabilities	136,699	167,225	292	167,517

## BENTLEY SYSTEMS, INCORPORATED AND SUBSIDIARIES

Notes to Consolidated Financial Statements (Continued)  
(in thousands, except share and per share data)

## Note 2: Recent Accounting Pronouncements (Continued)

	As of December 31,			
	2018	2019		
	As reported Topic 605	As adjusted Topic 605	Impact from the adoption of Topic 606 and Topic 340-40	As reported Topic 606
Deferred revenues	287,682	282,070	(77,079)	204,991
Income taxes payable	2,794	1,030	1,206	2,236
Total current liabilities	435,742	467,994	(75,581)	392,413
Long-term debt	258,750	233,750	—	233,750
Deferred revenues	49,769	56,121	(47,967)	8,154
Deferred income taxes	10,470	7,627	633	8,260
Income taxes payable	12,904	6,321	1,819	8,140
Other liabilities	8,530	9,263	—	9,263
Total liabilities	776,165	781,076	(121,096)	659,980
Stockholders' equity				
Common stock	2,502	2,548	—	2,548
Additional paid-in capital	392,896	408,667	—	408,667
Accumulated other comprehensive loss	(29,414)	(23,086)	(841)	(23,927)
Accumulated deficit <sup>(2)</sup>	(218,553)	(160,161)	107,492	(52,669)
Total stockholders' equity	\$ 147,431	\$ 227,968	\$ 106,651	\$ 334,619
Total liabilities and stockholders' equity	\$ 923,596	\$ 1,009,044	\$ (14,445)	\$ 994,599

- (1) As of December 31, 2019, contract cost assets of \$2,690 were included in *Prepaid and other current assets* and \$5,235 were included in *Other assets*.
- (2) Included in *Accumulated deficit* on the opening balance of January 1, 2019 is \$107,822, net of tax, for the cumulative effect adjustment of adopting Topics 606 and 340-40.

	Year Ended December 31,			
	2018	2019		
	As reported Topic 605	As adjusted Topic 605	Impact from the adoption of Topics 606 and 340-40	As reported Topic 606
Revenues:				
Subscriptions	\$ 557,421	\$ 613,925	\$(5,625)	\$ 608,300
Perpetual licenses	61,065	52,519	7,174	59,693
Subscriptions and licenses	618,486	666,444	1,549	667,993
Services	73,224	68,405	256	68,661
Total revenues	691,710	734,849	1,805	736,654
Cost of revenues:				
Cost of subscriptions and licenses	55,113	71,439	139	71,578

## BENTLEY SYSTEMS, INCORPORATED AND SUBSIDIARIES

Notes to Consolidated Financial Statements (Continued)  
(in thousands, except share and per share data)

## Note 2: Recent Accounting Pronouncements (Continued)

	Year Ended December 31,			
	2018	2019		
	As reported Topic 605	As adjusted Topic 605	Impact from the adoption of Topics 606 and 340-40	As reported Topic 606
Cost of services	76,211	72,572	—	72,572
Total cost of revenues	131,324	144,011	139	144,150
Gross profit	560,386	590,838	1,666	592,504
Operating expenses:				
Research and development	175,032	183,552	—	183,552
Selling and marketing	160,635	155,274	20	155,294
General and administrative	89,328	97,580	—	97,580
Amortization of purchased intangibles	14,000	14,213	—	14,213
Total operating expenses	438,995	450,619	20	450,639
Income from operations	121,391	140,219	1,646	141,865
Interest expense, net	(8,765)	(8,199)	—	(8,199)
Other income (expense), net	236	(5,557)	—	(5,557)
Income before income taxes	112,862	126,463	1,646	128,109
Provision for income taxes	(29,250)	21,762	1,976	23,738
Equity in loss of joint venture, net of tax	—	1,275	—	1,275
Net income	\$ 142,112	\$ 103,426	\$ (330)	\$ 103,096

## Note 3: Revenue from Contracts with Customers

On January 1, 2019, the Company adopted Topic 606 using the modified retrospective method, under which the cumulative effect of initially applying Topic 606 of \$125,464 (\$101,489, net of tax) was recorded as a reduction to the opening balance of *Accumulated deficit*. The impact from adoption was primarily derived from the timing of revenue recognition for perpetual licenses and the accounting for certain of the Company's subscription arrangements that include term-based software licenses bundled with support. Under prior guidance, revenue for perpetual licenses was recognized over a three-year period, while revenue attributable to the term-based software licenses was recognized ratably over the term. Under Topic 606, both perpetual license and term-based software license revenue will be recognized up-front upon delivery of the software license. The comparative information has not been adjusted and continues to be reported under Topic 605. Refer to Note 2, Recent Accounting Pronouncements, for a qualitative and quantitative discussion of the adoption impact.

Topic 606 establishes a principle for recognizing revenue upon the transfer of promised goods or services to customers, in an amount that reflects the expected consideration received in exchange for those goods or services.

## Nature of Products and Services

The Company generates revenues from subscriptions, perpetual licenses, and professional services.

## Subscriptions

*SELECT subscriptions* — A prepaid annual recurring subscription that accounts can elect to add to a new or previously purchased perpetual license. SELECT provides accounts with benefits, including upgrades,



## BENTLEY SYSTEMS, INCORPORATED AND SUBSIDIARIES

### Notes to Consolidated Financial Statements (Continued) (in thousands, except share and per share data)

#### Note 3: Revenue from Contracts with Customers (Continued)

comprehensive technical support, pooled licensing benefits, annual portfolio balancing exchange rights, learning benefits, certain Azure-based collaboration services, mobility advantages, and access to other available benefits. Under Topic 606, SELECT subscription revenues are recognized as distinct performance obligations are satisfied. The performance obligations within the SELECT offering, outside of the portfolio balancing exchange right, are concurrently delivered and have the same pattern of recognition. These performance obligations are accounted for ratably over the term as a single performance obligation. Under Topic 605, SELECT subscriptions revenue was recognized on a ratable basis, over the subscription term.

*Enterprise subscriptions* — The Company also provides Enterprise subscription offerings which provide its largest accounts with complete and unlimited global access to the Company’s comprehensive portfolio of solutions. Enterprise License Subscriptions (“ELS”) provide access for a prepaid fee, which is based on the account’s usage of software in the preceding year, effectively a fee-certain consumption-based arrangement. ELS contain a term license component, SELECT maintenance and support, and performance consulting days. The SELECT maintenance and support benefits under ELS do not include a portfolio balancing performance obligation. Revenue is allocated to the various performance obligations based on their respective standalone selling price (“SSP”). Revenue allocated to the term license component is recognized upon delivery at the start of the subscription term while revenues for the SELECT maintenance and support and the performance consulting days are recognized as delivered over the subscription term. Billings in advance are recorded as *Deferred revenues* in the consolidated balance sheets. Under Topic 605, ELS revenue was recognized on a ratable basis, over the subscription term.

E365 subscriptions (“E365”), which were introduced during the fourth quarter of 2018, provide unrestricted access to the Company’s comprehensive software portfolio, similar to ELS, however are charged based upon daily usage. The daily usage fee includes a term license component, SELECT maintenance and support, and Success Plan services, which are designed to achieve business outcomes through more efficient and effective use of our software. E365 revenues are recognized based upon usage incurred by the account under both Topics 606 and 605. Usage is defined as distinct user access on a daily basis. The term of E365 subscriptions aligns with calendar quarters and revenue is recognized based on actual usage.

*Term license subscriptions* — The Company provides annual, quarterly, and monthly term licenses for its software products. Term license subscriptions contain a term license component and SELECT maintenance and support. Revenue is allocated to the various performance obligations based on their SSP. Annual term licenses (“ATL”) are generally prepaid annually for named user access to specific products. Quarterly term license (“QTL”) subscriptions allow accounts to pay quarterly in arrears for license usage that is beyond their prepaid subscriptions. Monthly term license (“MTL”) subscriptions are identical to QTL subscriptions, except for the term of the license, and the manner in which they are monetized. MTL subscriptions require a Cloud Services Subscription (“CSS”), which is described below. For ATL, revenue allocated to the term license component is recognized upon delivery at the start of the subscription term while revenue for the SELECT maintenance and support is recognized as delivered over the subscription term. Billings in advance are recorded as *Deferred revenues* in the consolidated balance sheets. Under Topic 605, ATL revenues were recognized on a ratable basis, over the subscription term. For usage-based QTL and MTL subscriptions, revenues are recognized based upon usage incurred by the account under both Topics 606 and 605. Usage is defined as peak usage over the respective terms. The terms of QTL and MTL subscriptions align with calendar quarters and calendar months, respectively, and revenue is recognized based on actual usage.

Visas and Passports are quarterly or annual term licenses enabling users to access specific project or enterprise information and entitle certain functionality of the Company’s ProjectWise and AssetWise systems. The Company’s standard offerings are usage based with monetization through the Company’s CSS program.

**BENTLEY SYSTEMS, INCORPORATED AND SUBSIDIARIES**

**Notes to Consolidated Financial Statements (Continued)**  
**(in thousands, except share and per share data)**

**Note 3: Revenue from Contracts with Customers (Continued)**

CSS is a program designed to streamline the procurement, administration, and payment process. The program requires an account to estimate their annual usage for CSS eligible offerings and deposit funds in advance. Actual consumption is monitored and invoiced against the deposit on a calendar quarter basis. CSS balances not utilized for eligible products or services may roll over to future periods or are refundable. Paid and unconsumed CSS balances are recorded in *Accruals and other current liabilities* in the consolidated balance sheets. Software and services consumed under CSS are recognized pursuant to the applicable revenue recognition guidance for the respective software or service and classified as subscriptions or services based on their respective nature.

***Perpetual licenses***

Perpetual licenses may be sold with or without attaching a SELECT subscription. Historically, attachment and retention of the SELECT subscription has been high given the benefits of the SELECT subscription. Perpetual license revenue is recognized upon delivery of the license to the user under Topic 606. Under Topic 605, the Company recognized perpetual licenses revenue ratably over a three-year term due to the portfolio balancing feature users obtain through their SELECT subscriptions.

***Services***

The Company provides professional services including training, implementation, configuration, customization, and strategic consulting services. The Company performs projects on both a time and materials and a fixed fee basis. The Company's recent and preferred contractual structures for delivering professional services include (i) delivery of the services in the form of subscription-like, packaged offerings which are annually recurring in nature, and (ii) delivery of the Company's growing portfolio of Success Plans in standard offerings which offer a level of subscription service over and above the standard technical support offered to all accounts as part of their SELECT or Enterprise agreement. Revenues are recognized as services are performed under both Topic 606 and 605.

The Company primarily utilizes its direct internal sales force and also has arrangements through independent channel partners to promote and sell Bentley products and subscriptions to end-users. Channel partners are authorized to promote the sale of an authorized set of Bentley products and subscriptions within an authorized geography under a Channel Partner Agreement.

**Significant Judgments and Estimates**

The Company's contracts with customers may include promises to transfer licenses (perpetual or term-based), maintenance, and services to a user. Judgment is required to determine if the promises are separate performance obligations, and if so, the allocation of the transaction price to each performance obligation. When an arrangement includes multiple performance obligations which are concurrently delivered and have the same pattern of transfer to the customer, the Company accounts for those performance obligations as a single performance obligation. For contracts with more than one performance obligation, the transaction price is allocated among the performance obligations in an amount that depicts the relative SSP of each obligation. Judgment is required to determine the SSP for each distinct performance obligation. In instances where SSP is not directly observable, such as when the Company does not sell the product or service separately, the Company determines the SSP using information that may include market conditions and other observable inputs. The Company uses a range of amounts to estimate SSP when it sells each of the products and services separately and needs to determine whether there is a discount that should be allocated based on the relative SSP of the various products and services.

The Company's SELECT agreement provides users with perpetual licenses a right to exchange software for other eligible perpetual licenses on an annual basis upon renewal. The Company refers to this

## BENTLEY SYSTEMS, INCORPORATED AND SUBSIDIARIES

Notes to Consolidated Financial Statements (Continued)  
(in thousands, except share and per share data)

## Note 3: Revenue from Contracts with Customers (Continued)

option as portfolio balancing and concluded that the portfolio balancing feature represents a material right resulting in the deferral of the associated revenue. Judgment is required to estimate the percentage of users who may elect to portfolio balance and considers inputs such as historical user elections. This feature is available once per term and must be exercised prior to the respective renewal term. The Company recognizes the associated revenue upon election or when the portfolio balancing right expires. This right is included in the initial and subsequent renewal terms and the Company reestablishes the revenue deferral for the material right upon the beginning of the renewal term. As of December 31, 2019, the Company has deferred \$18,060 related to portfolio balancing exchange rights which is included in *Deferred revenues* on the consolidated balance sheet.

## Contract Assets and Contract Liabilities

	January 1, 2019	December 31, 2019
Contract assets	\$ 173	\$ 644
Deferred revenues	212,529	213,145

As of December 31, 2019, the Company's contract assets relate to performance obligations completed in advance of the right to invoice and are included in *Prepaid and other current assets*. Contract assets were not impaired as of December 31, 2019.

Deferred revenues consist of billings made or payments received in advance of revenue recognition from subscriptions, SELECT, and professional services. The timing of revenue recognition may differ from the timing of billings to users.

During the year ended December 31, 2019, \$202,354 of revenue that was included in the January 1, 2019 deferred revenue opening balance was recognized. There were additional deferrals of \$202,806, which were primarily related to new billings.

## Remaining Performance Obligations

The Company's contracts with customers include amounts allocated to performance obligations that will be satisfied at a later date. As of December 31, 2019, amounts allocated to these remaining performance obligations are \$213,145, of which the Company expects to recognize 96.2% over the next 12 months with the remaining amount thereafter.

## Disaggregation of Revenues

The following table details revenues:

	Year Ended December 31,		
	2018	2019	
	Topic 605	Topic 605	Topic 606
Revenues:			
Subscriptions:			
SELECT subscription revenues	\$273,745	\$267,340	\$267,249
Enterprise license subscriptions	182,816	196,081	184,833
Term license subscriptions	100,860	150,504	156,218
Subscriptions	557,421	613,925	608,300

## BENTLEY SYSTEMS, INCORPORATED AND SUBSIDIARIES

Notes to Consolidated Financial Statements (Continued)  
(in thousands, except share and per share data)

## Note 3: Revenue from Contracts with Customers (Continued)

	Year Ended December 31,		
	2018	2019	
	Topic 605	Topic 605	Topic 606
Perpetual licenses:			
Perpetual licenses	61,065	52,519	59,693
Subscriptions and licenses	618,486	666,444	667,993
Services:			
Professional services (recurring)	25,981	22,974	22,797
Professional services (all other)	47,243	45,431	45,864
Services	73,224	68,405	68,661
Total revenues	<u>\$691,710</u>	<u>\$734,849</u>	<u>\$736,654</u>

The Company recognizes perpetual licenses and the term license component of subscriptions as revenue when either the licenses are delivered or at the start of the subscription term. For the year ended December 31, 2019, the Company recognized \$311,689 of license related revenues, of which \$251,996 was attributable to the term license component of the Company's subscription based commercial offerings recorded in Subscriptions.

Under Topic 606, the Company derived 8% of its total revenues through channel partners for the year ended December 31, 2019.

Revenue to external customers is attributed to individual countries based upon the location of the customer.

	Year Ended December 31,		
	2018	2019	
	Topic 605	Topic 605	Topic 606
Revenues:			
Americas <sup>(1)</sup>	\$328,749	\$360,934	\$356,331
Europe, the Middle East, and Africa <sup>(2)</sup>	231,486	235,254	236,602
Asia Pacific	131,475	138,661	143,721
Total Revenues	<u>\$691,710</u>	<u>\$734,849</u>	<u>\$736,654</u>

(1) Americas includes the United States, Canada, and Latin America (including the Caribbean). Revenue attributable to the United States totaled \$277,706 (Topic 605) for the year ended December 31, 2018 and \$307,259 (Topic 605) and \$306,493 (Topic 606) for the year ended December 31, 2019.

(2) Revenue attributable to the United Kingdom totaled \$59,086 (Topic 605) for the year ended December 31, 2018 and \$59,524 (Topic 605) and \$57,321 (Topic 606) for the year ended December 31, 2019.

Adoption of the standards had no impact to net cash provided by or used in operating, financing, or investing activities on the Company's consolidated statement of cash flows.

## Note 4: Acquisitions

During the years ended December 31, 2018 and 2019, the Company completed a number of acquisitions, none of which were material, individually or in the aggregate, to the Company's consolidated statements of operations. The aggregate details of the Company's acquisition activity are as follows:

## BENTLEY SYSTEMS, INCORPORATED AND SUBSIDIARIES

Notes to Consolidated Financial Statements (Continued)  
(in thousands, except share and per share data)

## Note 4: Acquisitions (Continued)

	Acquisitions Completed in Year Ended December 31,	
	2018	2019
Number of acquisitions	7	4
Cash paid at closing	\$143,038	\$36,577
Cash acquired	(7,774)	(2,523)
Net cash paid	<u>\$135,264</u>	<u>\$34,054</u>

As of December 31, 2018, the fair value of the contingent consideration related to acquisitions totaled \$4,316, of which \$2,390 is included in *Accruals and other current liabilities* and \$1,926 is included in *Other liabilities* on the consolidated balance sheet.

As of December 31, 2019, the fair value of the contingent consideration related to acquisitions totaled \$6,599, of which \$5,100 is included in *Accruals and other current liabilities* and \$1,499 is included in *Other liabilities* on the consolidated balance sheet.

One of the 2018 acquisitions required the Company to pay former shareholders a revenue based earn-out contingent on meeting certain 2018 revenue targets. As of December 31, 2018, such revenue targets were met and as a consequence \$8,516 was reclassified to non-contingent consideration from acquisitions within *Accruals and other current liabilities*. The remaining contingent consideration as of December 31, 2018 was payable to former shareholders across 2017 and 2018 acquisitions if certain acquisition related key employees remained employed with the Company through certain periods.

As of December 31, 2018 and 2019, total current deferred payment obligations including contingent consideration for all acquisitions were \$11,019 and \$5,999, respectively and are included in *Accruals and other current liabilities* on the consolidated balance sheet.

As of December 31, 2018 and 2019, total long-term deferred payment obligations including contingent consideration for all acquisitions were \$2,826 and \$1,499, respectively and are included in *Other liabilities* on the consolidated balance sheets.

The operating results of the acquired businesses are included in the Company's consolidated financial statements from the closing date of each respective acquisition. The purchase price for each acquisition has been allocated to the net tangible and intangible assets and liabilities based on their estimated fair values at the acquisition date. Independent valuations are obtained to support purchase price allocations when deemed appropriate.

In connection with the purchase price allocations related to the Company's acquisitions, the Company has estimated the fair values of the support obligations assumed relative to acquired deferred revenue. The estimated fair values of the support obligations assumed were determined using a cost-build-up approach. The cost-build-up approach determines fair value by estimating the costs related to fulfilling the obligations plus a normal profit margin. For accounting purposes, the sum of the costs and operating profit approximates the amount that the Company would be required to pay a third party to assume the support obligations. These fair value adjustments reduce the revenues recognized over the remaining support contract term of the Company's acquired contracts. During the years ended December 31, 2018 and 2019, the fair value adjustments to reduce revenue were \$2,469 and \$553, respectively.

The purchase accounting for three of our acquisitions, which were completed during the year ended December 31, 2019, is not yet finalized. Identifiable assets acquired and liabilities assumed were provisionally recorded at their estimated fair values on the acquisition date. The initial accounting for these business

## BENTLEY SYSTEMS, INCORPORATED AND SUBSIDIARIES

Notes to Consolidated Financial Statements (Continued)  
(in thousands, except share and per share data)

## Note 4: Acquisitions (Continued)

combinations is not complete because the evaluation necessary to assess the fair values of certain net assets acquired is still in process. The provisional amounts are subject to revision until the evaluations are completed to the extent that additional information is obtained about the facts and circumstances that existed as of the acquisition date. The allocation of the purchase price may be modified from the date of the acquisition as more information is obtained about the fair values of assets acquired and liabilities assumed, however such measurement period cannot exceed one year.

Acquisition and integration costs are expensed as incurred. During the years ended December 31, 2018 and 2019, the Company incurred acquisition and integration costs of \$1,361 and \$950, respectively, which include costs related to legal, accounting, valuation, general administrative, and other consulting fees. Such costs are recorded in *General and administrative* in the Company's consolidated statements of operations.

The following summarizes the fair values of the assets acquired and liabilities assumed as well as the weighted average useful lives assigned to acquired intangible assets at the respective date of each acquisition (including contingent consideration):

	Acquisitions Completed in Year Ended December 31,	
	2018	2019
Consideration:		
Cash paid at closing	\$143,038	\$36,577
Contingent consideration	13,456	4,498
Deferred payment obligations to sellers	690	—
Total consideration	<u>\$157,184</u>	<u>\$41,075</u>
Assets acquired and liabilities assumed:		
Cash	\$ 7,774	\$ 2,523
Prepaid and other current assets	4,790	1,782
Property and equipment	340	411
Other assets	—	84
Customer relationship asset (weighted average useful life of 5 and 7 years, respectively)	27,294	6,534
Software and technology (weighted average useful life of 3 years)	9,332	2,423
In-process research and development	1,366	—
Non-compete agreement (useful life of 5 years)	—	150
Trademarks (weighted average useful life of 7 and 5 years)	2,090	1,431
Total identifiable assets acquired excluding goodwill	<u>52,986</u>	<u>15,338</u>
Deferred tax liability	(8,917)	(1,869)
Other current liabilities	(3,848)	(3,538)
Deferred revenues	(6,181)	(2,897)
Total liabilities assumed	<u>(18,946)</u>	<u>(8,304)</u>
Net identifiable assets acquired excluding goodwill	34,040	7,034
Goodwill	123,144	34,041
Net assets acquired	<u>\$157,184</u>	<u>\$41,075</u>

**BENTLEY SYSTEMS, INCORPORATED AND SUBSIDIARIES**

**Notes to Consolidated Financial Statements (Continued)**  
**(in thousands, except share and per share data)**

**Note 4: Acquisitions (Continued)**

The fair values of the working capital, other assets (liabilities), and property and equipment approximated their respective carrying values as of the acquisition date.

As discussed above, the fair values of deferred revenues were determined using the cost-build-up approach.

The fair values of the intangible assets were primarily determined using the income approach. When applying the income approach, indications of fair values were developed by discounting future net cash flows to their present values at market-based rates of return. The cash flows were based on estimates used to price the acquisitions and the discount rates applied were benchmarked with reference to the implied rate of return from the Company's pricing model and the weighted average cost of capital.

Goodwill recorded in connection with the acquisition was attributable to synergies expected to arise from cost saving opportunities as well as future expected cash flows. Of the goodwill recorded, \$6,501 is expected to be deductible for tax purposes.

**Note 5: Property and Equipment, Net**

Property and equipment, net consist of the following at December 31, 2018 and 2019:

	As of December 31,	
	2018	2019
Land	\$ 2,811	\$ 2,811
Building and improvements	30,585	31,619
Computer equipment and software	46,938	47,472
Furniture, fixtures, and equipment	11,595	12,593
Aircraft	3,910	3,910
Other	61	79
Property and equipment, at cost	95,900	98,484
Less accumulated depreciation	(66,507)	(68,852)
Total property and equipment, net	<u>\$ 29,393</u>	<u>\$ 29,632</u>

Depreciation expense for the years ended December 31, 2018 and 2019 was \$9,300 and \$9,813, respectively.

**Note 6: Goodwill and Other Intangible Assets**

The changes in the carrying amount of goodwill for the years ended December 31, 2018 and 2019 are as follows:

Balance, December 31, 2017	\$336,982
Acquisitions	123,144
Foreign currency translation adjustments	(13,808)
Balance, December 31, 2018	446,318
Acquisitions	34,041
Foreign currency translation adjustments	(321)
Other adjustments	27
Balance, December 31, 2019	<u>\$480,065</u>

## BENTLEY SYSTEMS, INCORPORATED AND SUBSIDIARIES

Notes to Consolidated Financial Statements (Continued)  
(in thousands, except share and per share data)

## Note 6: Goodwill and Other Intangible Assets (Continued)

Details of intangible assets other than goodwill as of December 31, 2018 and 2019 are as follows:

	Estimated Useful Life	As of December 31, 2018			As of December 31, 2019		
		Gross Carrying Amount	Accumulated Amortization	Net Book Value	Gross Carrying Amount	Accumulated Amortization	Net Book Value
<b>Intangible assets subject to amortization</b>							
Software and technology	3 years	\$ 66,251	\$ (57,937)	\$ 8,314	\$ 66,063	\$ (58,866)	\$ 7,197
Customer relationships	3 – 10 years	86,364	(52,753)	33,611	88,904	(59,744)	29,160
Trademarks	3 – 10 years	20,799	(8,952)	11,847	22,278	(12,461)	9,817
Non-compete agreements	5 years	—	—	—	150	(11)	139
		<u>173,414</u>	<u>(119,642)</u>	<u>53,772</u>	<u>177,395</u>	<u>(131,082)</u>	<u>46,313</u>
<b>Intangible assets not subject to amortization</b>							
In-process research and development		229	—	229	—	—	—
<b>Total intangible assets</b>		<u>\$173,643</u>	<u>\$(119,642)</u>	<u>\$54,001</u>	<u>\$177,395</u>	<u>\$(131,082)</u>	<u>\$46,313</u>

The aggregate amortization expense for purchased intangible assets with finite lives recorded for the years ended December 31, 2018 and 2019 was reflected in our consolidated statements of operations as follows:

	Year Ended December 31,	
	2018	2019
Cost of subscriptions and licenses	\$ 2,840	\$ 3,795
Amortization of purchased intangibles	14,000	14,213
<b>Total amortization expense</b>	<u>\$16,840</u>	<u>\$18,008</u>

Amortization expense for the years following December 31, 2019 are estimated as follows:

2020	\$17,422
2021	11,963
2022	8,543
2023	3,798
2024	2,058
Thereafter	2,529
	<u>\$46,313</u>

## Note 7: Investment in Joint Venture

In September 2019, the Company and Topcon Positioning Systems, Inc. formed Digital Construction Works, Inc. (“DCW”), a joint venture which operates as a digital integrator of software and cloud services for the construction industry. DCW’s focus is to transform the construction industry from its legacy document-centric paradigm by simplifying and enabling digital automated workflows and processes, technology integration, and digital twinning services for infrastructure.



## BENTLEY SYSTEMS, INCORPORATED AND SUBSIDIARIES

Notes to Consolidated Financial Statements (Continued)  
(in thousands, except share and per share data)**Note 7: Investment in Joint Venture (Continued)**

The Company and Topcon each have a 50% ownership in DCW and as such, the Company applies the equity method of accounting for its investment in DCW. Under the equity method, the Company recorded its initial investment in the joint venture at cost and subsequently adjusts that investment by the Company's proportional share of income or losses in DCW. As of December 31, 2019, the aggregate carrying amount of the Company's investment in the joint venture was \$1,725. The Company tests this investment for impairment whenever circumstances indicate that the carrying value of the investment may not be recoverable.

Pursuant to ASC 850-10-20, *Related Party Disclosures*, the Company has determined that DCW is a related party. For the year ended December 31, 2019, transactions between the Company and DCW were immaterial to the Company's consolidated financial statements.

**Note 8: Accruals and Other Current Liabilities**

Accruals and other current liabilities consist of the following:

	As of December 31,	
	2018	2019
Cloud Services Subscription deposits	\$ 25,541	\$ 54,688
Accrued benefits	25,863	33,184
Accrued compensation	30,484	31,537
Due to customers	8,467	8,945
Contingent consideration from acquisitions	2,390	5,100
Sales taxes payable	3,467	5,287
Accrued professional fees	2,347	4,382
Accrued acquisition stay bonuses	1,650	4,143
Accrued hosting costs	6,740	2,215
Accrued facility costs	2,269	2,168
Accrued rent	2,574	1,909
Accrued severance and realignment costs	6,555	1,688
Non-contingent consideration from acquisitions	8,629	900
Other accrued and current liabilities	9,723	11,371
Total accruals and other current liabilities	<u>\$136,699</u>	<u>\$167,517</u>

**Note 9: Long-Term Debt**

Long-term debt consists of the following at December 31, 2018 and 2019:

	As of December 31,	
	2018	2019
Bank credit facility:		
Senior secured revolver	\$258,750	\$233,750
Total long-term debt	<u>\$258,750</u>	<u>\$233,750</u>

**Bank Credit Facility**—On December 19, 2017, the Company entered into an amended and restated credit agreement (the "Credit Facility"), which matures on December 18, 2022. Upon entry into the Credit

## BENTLEY SYSTEMS, INCORPORATED AND SUBSIDIARIES

### Notes to Consolidated Financial Statements (Continued) (in thousands, except share and per share data)

#### **Note 9: Long-Term Debt (Continued)**

Facility, the Company obtained a \$500,000 senior secured revolving facility and refinanced all indebtedness outstanding under its prior facility.

In addition to the revolving line of credit, the Credit Facility also provides up to \$50,000 of letters of credit and other incremental borrowings subject to availability, including a \$50,000 multi-currency swing-line sub-facility and a \$100,000 incremental “accordion” sub-facility. The Company had \$631 and \$546 of letters of credit and surety bonds outstanding as of December 31, 2018 and 2019, respectively. As of December 31, 2018 and 2019, the Company had \$240,619 and \$265,704 available under the Credit Facility.

Under the Credit Facility, the Company may make either Euro currency or non-Euro currency interest rate elections. Interest on the Euro currency borrowings is at the one-month London Interbank Offered Rate (“LIBOR”) plus a spread ranging from 100 basis points (“bps”) to 225 bps as determined by the Company’s net leverage ratio. Under non-Euro currency elections, Credit Facility borrowings bear a base interest rate of the greater of (i) the prime rate, (ii) the overnight bank funding effective rate plus 50 bps, or (iii) LIBOR plus 100 bps, plus a spread ranging from 0 bps to 125 bps as determined by the Company’s leverage ratio. In addition, a commitment fee for the unused Credit Facility ranges from 15 bps to 30 bps as determined by the Company’s net leverage ratio.

Borrowings under the Credit Facility are guaranteed by all of the Company’s first tier domestic subsidiaries and are secured by a first priority security interest in substantially all of the Company’s and the guarantors’ U.S. assets and 65% of the stock of their directly owned foreign subsidiaries. The Credit Facility contains both affirmative and negative covenants, including maximum leverage ratios. At December 31, 2018 and 2019, the Company was in compliance with all covenants in its debt agreements.

For the years ended December 31, 2018 and 2019, the weighted average interest rate under the Credit Facility was 3.28% and 3.47%, respectively. There was no accrued interest or fees as of December 31, 2019. As of December 31, 2018, accrued interest and fees was \$31. Interest expense was \$8,800 and \$8,971 for the years ended December 31, 2018 and 2019, respectively.

In addition, interest expense includes amortization of deferred financing costs of \$552 and \$553 for the years ended December 31, 2018 and 2019.

*Other*—Interest expense related to other obligations was \$255 and \$207 for the years ended December 31, 2018 and 2019, respectively.

#### **Note 10: Executive Bonus Plan**

The Company has an incentive compensation program under which up to 20% of the Company’s adjusted operating profits, as defined in the plan agreement and before deductions for such plan payments, may be paid to plan participants in the form of cash bonuses, subject to approval by the Company’s board of directors and certain limitations imposed by the Company’s Credit Facility. The plan permits the deduction of certain holdback amounts from the plan’s pool, from which amounts can then be allocated to fund items including equity and/or cash incentive compensation for non-plan participants and participant charitable contributions. During the years ended December 31, 2018 and 2019, the incentive compensation, including cash payments and deferred compensation to plan participants, recognized under this plan (net of all applicable holdbacks) was \$27,641 and \$31,061, respectively.

#### **Note 11: Retirement Plans**

The Company maintains a qualified 401(k) profit sharing plan (the Plan) for the benefit of substantially all U.S.-based full-time colleagues. The Company may make discretionary profit-sharing contributions to the Plan up to a maximum of 5% of “qualified cash compensation” for each eligible participating colleague.

**BENTLEY SYSTEMS, INCORPORATED AND SUBSIDIARIES**

**Notes to Consolidated Financial Statements (Continued)**  
**(in thousands, except share and per share data)**

**Note 11: Retirement Plans (Continued)**

Non-discretionary (matching) 401(k) contributions to the Plan, for full-time U.S. colleagues, were \$3,337 and \$3,311, for the years ended December 31, 2018 and 2019, respectively. The Company also maintains various retirement benefit plans (primarily defined contribution plans) for colleagues of its international subsidiaries. Contributions to these plans were \$7,613 and \$8,070, for the years ended December 31, 2018 and 2019, respectively.

The Company also has a nonqualified deferred compensation plan (the “DCP”), under which certain officers and key colleagues may elect to defer the receipt of all or a portion of their bonus compensation. In addition, the Company may make discretionary awards under the DCP on behalf of the participants. Elective participant deferrals and discretionary Company awards are required to be in the form of phantom shares of the Company’s Class B Non-Voting Common Stock (“Class B Common Stock”), which are valued for tax and accounting purposes in the same manner as actual shares of Class B Common Stock. All DCP distributions to current colleague participants are made in the form of shares of Class B Common Stock. The Company’s discretionary awards made prior to January 1, 2016 vest 20% on the date of grant and 20% on each of the four subsequent anniversary dates. The Company’s discretionary awards made on or after January 1, 2016 are 100% vested at the time of grant. No discretionary contributions were made to the DCP during the years ended December 31, 2018 or 2019.

Amounts in the DCP attributable to certain non-colleague participants are settled in cash and are classified as liabilities which are marked to market at the end of each reporting period. The total liability related to the DCP for non-colleague participants was \$2,275 and \$2,544 as of December 31, 2018 and 2019, respectively.

The table below shows compensation (income) expense related to the DCP recorded during the years ended December 31, 2018 and 2019:

	<u>Year Ended</u> <u>December 31,</u>	
	<u>2018</u>	<u>2019</u>
DCP related compensation (income) expense	\$(75)	\$408

**Note 12: Common Stock**

**Authorized Common Shares**— The Company amended and restated its Certificate of Incorporation on April 20, 2018 to authorize 320,000,000 shares of Class A Voting Common Stock (“Class A Common Stock”) and 600,000,000 shares of Class B Common Stock. As of December 31, 2018 and 2019, outstanding shares of Class A Common Stock totaled 11,601,757 and outstanding shares of Class B Common Stock totaled 238,681,756 and 243,241,192, respectively.

**Sales, Repurchases, and Issuances of Company Capital Stock**

In September 2016, the Company entered into a Class B Common Stock Purchase Agreement with a strategic investor (the “Common Stock Purchase Agreement”), pursuant to which the investor could acquire in a series of transactions up to \$200,000 of the Company’s Class B Common Stock at the then prevailing fair market value, either directly from selling stockholders, in which case the Company would act as pass through agent, or by funding the Company’s repurchase and subsequent sale to the investor of shares acquired by the Company from existing Company stockholders.

The Common Stock Purchase Agreement grants to the strategic investor certain informational and protective rights, including, for so long as the Company remains party to a long-term strategic collaboration agreement with the investor, a pre-initial public offering (“IPO”) right of first refusal on any sale of the Company and a post-IPO right to participate in any sale process the Company may undertake.

**BENTLEY SYSTEMS, INCORPORATED AND SUBSIDIARIES**

**Notes to Consolidated Financial Statements (Continued)**  
**(in thousands, except share and per share data)**

**Note 12: Common Stock (Continued)**

On April 23, 2018, the Company entered into an amendment to the Common Stock Purchase Agreement, which (i) increased the maximum purchase amount from \$200,000 to \$250,000 thereunder, (ii) extended the expiration of the agreement from 2026 to 2030, and (iii) granted the Company the right to retain a portion of the shares that would otherwise be sold to the investor.

During the year ended December 31, 2018, the investor acquired 5,151,019 shares of Class B Common Stock, with 2,139,466 of such shares having been repurchased by the Company and re-sold to the investor for consideration of \$16,220 and 3,011,553 shares were acquired directly by the investor for consideration of \$22,792.

During the year ended December 31, 2019, the investor purchased 791,873 shares under the Common Stock Purchase Agreement, with 622,873 of such shares having been repurchased by the Company and re-sold to the investor for consideration of \$4,510 and 169,000 shares acquired directly by the investor for consideration of \$1,224.

During the year ended December 31, 2018, the Company issued net 2,812,998 shares of Class B Common Stock to colleagues who exercised their stock options. Of the total options exercised for 3,726,606 shares, 1,235,204 shares were issued for cash totaling \$2,187, and the remaining options for 2,491,402 shares were exercised on a cashless basis, and accordingly, 913,608 shares were sold back to the Company to pay for the cost of the options as well as applicable income tax withholdings of \$1,577. During 2018, the Company paid \$8,571 for 1,131,928 shares sold back to the Company upon exercise of the Put and Call provisions under the amended option plan (see Note 14).

During the year ended December 31, 2019, the Company issued net 3,214,542 shares of Class B Common Stock to colleagues who exercised their stock options. Of the total options exercised for 4,731,158 shares, 1,273,271 shares were issued for cash totaling \$3,627, and the remaining options for 3,457,887 shares were exercised on a cashless basis, and accordingly, 1,516,616 shares were sold back to the Company to pay for the cost of the options as well as applicable income tax withholdings of \$2,324. During the year ended December 31, 2019, the Company paid \$8,838 for 1,126,747 shares sold back to the Company upon exercise of the Put and Call provisions under the amended option plan (see Note 14).

During the years ended December 31, 2018 and December 31, 2019, the Company issued 2,332,585 and 2,322,983, respectively, of shares of Class B Common Stock to DCP participants for their distribution. The distribution in shares for the year ended December 31, 2018 totaled 3,340,904 of which 1,008,319 shares were sold back to the Company to pay for the cost of applicable income tax withholding of \$6,861. The distribution in shares for the year ended December 31, 2019 totaled 3,082,607 shares of which 759,624 shares were sold back to the Company in the same period to pay for applicable income tax withholdings of \$5,609.

During 2018 and 2019, the Company repurchased 465,979 and 318,203 shares from its profit sharing plan for \$3,387 and \$2,417, respectively.

**Selected Terms of Class B Common Stock**—Pursuant to the terms of the Company's amended and restated Certificate of Incorporation in effect for the periods reported, each share of Class B Common Stock has the same rights and privileges as each share of Class A Common Stock, except that the holders of outstanding shares of Class B Common Stock do not have any right to vote on, or consent with respect to, any matters to be voted on or consented to by the stockholders of the Company except as required by law, and the shares of Class B Common Stock are not included in determining the number of shares voting or entitled to vote on any such matters. Each outstanding share of Class B Common Stock may be converted into one share of Class A Common Stock upon the determination of the Company's board of directors. Additionally, absent a conversion by the board of directors, upon an IPO by the Company, each outstanding share of Class B Common Stock may be automatically converted into the class of common stock being offered.

## BENTLEY SYSTEMS, INCORPORATED AND SUBSIDIARIES

Notes to Consolidated Financial Statements (Continued)  
(in thousands, except share and per share data)

## Note 12: Common Stock (Continued)

*Dividends*—The Company declared cash dividends during the periods presented as follows:

	Dividend Per Share	Amount
2018:		
Fourth quarter	\$0.020	\$ 4,990
Third quarter	0.020	5,016
Second quarter	0.020	5,020
First quarter	0.020	4,979
Total	<u>\$0.080</u>	<u>\$20,005</u>
2019:		
Fourth quarter	\$0.025	\$ 6,367
Third quarter	0.025	6,380
Second quarter	0.025	6,375
First quarter	0.025	6,268
Total	<u>\$0.100</u>	<u>\$25,390</u>

## Note 13: Accumulated Other Comprehensive Loss

Accumulated other comprehensive loss consists of the following:

	Foreign Currency Translation	Actuarial (Loss) Gain on Retirement Plan	Total
Balance, December 31, 2017	\$(17,847)	\$ (693)	\$(18,540)
Other comprehensive income (loss), before taxes	(11,020)	208	(10,812)
Tax expense	—	(62)	(62)
Other comprehensive income (loss), net of taxes	(11,020)	146	(10,874)
Balance, December 31, 2018	<u>(28,867)</u>	<u>(547)</u>	<u>(29,414)</u>
Other comprehensive income (loss), before taxes	5,959	(675)	5,284
Tax expense	—	203	203
Other comprehensive income (loss), net of taxes	5,959	(472)	5,487
Balance, December 31, 2019	<u>\$(22,908)</u>	<u>\$(1,019)</u>	<u>\$(23,927)</u>

## Note 14: Equity Awards and Instruments

The Company has equity awards outstanding under its 2005 Stock Option Plan and 2015 Equity Incentive Plan. The 2015 Equity Incentive Plan provides for the granting of awards in the form of stock options, stock appreciation rights, dividend equivalent rights, restricted stock, restricted stock units, and stock grants. The 2005 Stock Option Plan expired in April 2015, and no further options may be granted thereunder. The 2015 Equity Incentive Plan, which has substantially similar terms to the 2005 Stock Option Plan as it relates to options, has 50,000,000 shares of Class B Common Stock reserved for issuance and terminates in November 2024.

The following is a summary of activity under these two stockholder-approved plans.

**BENTLEY SYSTEMS, INCORPORATED AND SUBSIDIARIES**

**Notes to Consolidated Financial Statements (Continued)**  
**(in thousands, except share and per share data)**

**Note 14: Equity Awards and Instruments (Continued)**

**Stock Options**—The Company has stock options outstanding under its 2005 Stock Option Plan and 2015 Equity Incentive Plan. Stock options generally vest ratably on each of the first four anniversaries of the grant date. Stock options granted under these plans include Put and Call provisions that allow colleagues who have exercised an option to sell all or part of their shares acquired upon such exercise to the Company at the fair market value at the time of the sale. The exercise period for the Put right begins on the second day after the six-month anniversary of the date the option was exercised and ends after an additional 30 days. The Call right provision allows the Company to purchase all or a part of the shares acquired by a colleague upon exercise of an option, at the fair market value at the time of such purchase. The Company may exercise the Call right at any time within seven months of the later of i) the optionee's termination of service with the Company, or ii) the optionee's (or his or her beneficiary's) exercise of such option after a termination of service.

The Company granted a total of 20,000 options on March 22, 2018, 5,096,000 options on May 29, 2018, and 10,000 options on September 6, 2018. The fair value of the awards was estimated on the date of grant using the Black-Scholes option pricing model. The grant date fair value of each option was \$1.43, \$1.46, and \$1.96, respectively.

The Company granted a total of 4,816,000 options on March 22, 2019 and 10,000 options on May 15, 2019. The fair value of the awards was estimated on the date of grant using the Black-Scholes option pricing model. The grant date fair value of each option was \$1.66 and \$1.65, respectively.

**Acquisition Options**—In connection with an acquisition completed in March 2018, the Company issued to certain selling shareholder entities options to acquire an aggregate of up to 900,000 shares of Class B Common Stock. The options have a five-year term, vest on the fourth anniversary of the closing of the acquisition, and an initial exercise price of \$6.805 per share. The exercise price of the options is subject to a cap and collar adjustment mechanism that automatically reduces (but not to less than \$0.01) or increases the exercise price based on the difference between the exercise price and the fair market value of the Company's Class B Common Stock on the exercise date. The fair value of the awards was estimated on the date of grant using the Black-Scholes option pricing model. The grant date fair value of each option was \$3.44. Any shares of Class B Common Stock acquired upon exercise of the options are generally entitled to the Put and Call rights summarized above under "Stock Options," and the options contain customary adjustment provisions in case of stock splits, stock dividends, or other corporate transactions (see Note 1 regarding the Dividend). As of December 31, 2019, all 900,000 options remain outstanding.

**Stock Grants**—Under the 2015 Equity Incentive Plan, the Company may grant unrestricted, fully vested shares of Class B Common Stock to eligible colleagues. Any such shares awarded have Put and Call rights similar to those described above with respect to stock options.

The Company did not grant fully vested shares of Class B Common Stock during 2018 or 2019.

**Restricted Stock**—Under the 2015 Equity Incentive Plan, the Company may grant both time and performance-based shares of restricted Class B Common Stock to eligible colleagues.

During the year ended December 31, 2018, the Company granted 512,616 shares of restricted stock, all of which were subject to performance-based vesting as determined by the achievement of business growth targets, which included growth in annual recurring revenues as well as actual bookings for perpetual licenses and non-recurring services. Annual performance targets were seasonalized and targets were set for quarterly and annual performance periods ending on December 31, 2018. These restricted shares carried dividend, but not voting rights. During the year ended December 31, 2018, the performance conditions to vesting were satisfied in respect of 451,784 of these shares, of which 76,375 shares were sold back to the Company to settle applicable income tax withholdings of \$610. An additional 4,798 shares were sold back to the Company to settle applicable income tax withholdings of \$27, related to performance shares that were vested in 2017 and

## BENTLEY SYSTEMS, INCORPORATED AND SUBSIDIARIES

Notes to Consolidated Financial Statements (Continued)  
(in thousands, except share and per share data)

## Note 14: Equity Awards and Instruments (Continued)

delivered to participants in the year ended December 31, 2018. Additionally, during the year ended December 31, 2018, the Company granted 57,670 shares of restricted stock to a colleague. These restricted shares carry dividend but not voting rights, and are subject to a three-year service condition.

For the year ended December 31, 2019, the Company granted 493,840 shares of restricted stock, all of which were subject to performance-based vesting as determined by the achievement of business growth targets which included growth in annual recurring revenues as well as actual bookings for perpetual licenses and non-recurring services. Annual performance targets were seasonalized and targets were set for quarterly and annual performance periods ending on December 31, 2019. These restricted shares carried dividend, but not voting rights. During the year ended December 31, 2019, the performance conditions to vesting were satisfied in respect of 241,709 of these shares, of which 25,677 shares were sold back to the Company to settle applicable income tax withholdings of \$192. An additional 23,343 shares were sold back to the Company to settle applicable income tax withholdings of \$169, related to performance shares that were vested in 2018 and delivered to participants in the year ended December 31, 2019.

**Restricted Stock Units**—Under the 2015 Equity Incentive Plan, the Company may grant both time and performance based restricted stock units (“RSUs”) to eligible colleagues, which entitle the grantee to receive a specific number of shares of our Class B Common Stock upon vesting. These shares also have dividend equivalent rights.

No restricted stock units were granted during the years ended December 31, 2018 or 2019. In 2016, the Company granted RSUs subject to performance-based vesting as determined by the achievement of business growth targets which included growth in annual recurring revenues as well as actual bookings for perpetual licenses and non-recurring services. Annual performance targets were seasonalized and targets were set for quarterly and annual performance periods ending on December 31, 2016. Certain colleagues elected to defer delivery of such shares upon vesting. During the year ended December 31, 2019, 16,746 shares were delivered to colleagues and 5,398 shares were sold back to the Company to settle income tax withholdings of \$39. As of December 31, 2018 and 2019, 70,687 and 54,771, respectively, of these RSUs remained outstanding.

The following is a summary of option activity under the Company’s equity incentive plans:

	Options Outstanding	Exercise Price Per Share	
		Range	Weighted Average
<b>Balance, December 31, 2017</b>	18,629,380	\$0.31 - \$5.38	\$ 3.72
Option activity:			
Granted	5,126,000	6.81 - 8.67	6.81
Exercised	(3,738,182)	0.31 - 5.38	1.89
Canceled	(502,750)	0.31 - 8.67	5.04
<b>Balance, December 31, 2018</b>	<u>19,514,448</u>	\$1.79 - \$6.81	\$ 4.85
Option activity:			
Granted	4,826,000	7.24	7.24
Exercised	(4,731,158)	1.79 - 6.81	2.68
Canceled	(917,623)	1.79 - 7.24	5.82
<b>Balance, December 31, 2019</b>	<u>18,691,667</u>	\$3.50 - \$7.24	\$ 5.97

As of December 31, 2018 and 2019, options and other equity awards available for future grants under the 2015 Equity Incentive Plan were 30,607,529 and 28,101,504, respectively.

## BENTLEY SYSTEMS, INCORPORATED AND SUBSIDIARIES

Notes to Consolidated Financial Statements (Continued)  
(in thousands, except share and per share data)

## Note 14: Equity Awards and Instruments (Continued)

The following is a summary of options outstanding and exercisable by exercise price as of December 31, 2019:

Exercise Prices	Number of Options Outstanding	Weighted Remaining Contractual Life (in years)	Exercisable
\$3.50 – \$4.00	1,978,256	0.39	1,978,256
4.01 – 6.00	7,450,203	1.78	4,469,866
\$6.01 – \$7.24	9,263,208	3.82	1,125,708
Total	18,691,667		7,573,830

During the years ended December 31, 2018 and 2019, the Company received cash proceeds of \$2,179 and \$3,612, respectively, related to the exercise of stock options.

The following is a summary of the intrinsic value of options outstanding and exercisable as of December 31, 2019:

	Number of Options	Weighted Average Exercise Price	Aggregate Intrinsic Value	Weighted Remaining Contractual Life (in years)
Options as of December 31, 2019				
Outstanding	18,691,667	\$5.97	\$91,028	2.6
Exercisable	7,573,830	\$5.05	\$43,852	1.6

Compensation expense is recognized on a straight-line basis over the vesting period during which colleagues perform related services. In the years ended December 31, 2018 and 2019, the Company recorded \$4,808 and \$6,342, respectively, of stock-based compensation expense related to stock options and \$3,074 and \$1,749, respectively, of compensation expense in connection with restricted stock. As of December 31, 2019, there was \$11,911 of unrecognized compensation cost related to unvested stock options, which is expected to be recognized over a weighted average period of approximately 2.6 years.

The total intrinsic value of stock options exercised in the years ended December 31, 2018 and 2019 was \$18,291 and \$22,914, respectively.

The value of each stock option award was estimated on the date of grant using the Black-Scholes option pricing model. The determination of the fair value of share-based payment awards using an option pricing model is affected by the Company's stock price as well as assumptions regarding a number of complex and subjective variables. These variables include the Company's expected stock price volatility over the term of the awards, actual and projected colleague stock option exercise behaviors, risk-free interest rates, and expected dividends, which are estimated as follows:

*Expected volatility.* The expected stock price volatility for the Company's common stock was estimated by taking the average historic price volatility for industry peers based on daily price observations over a period equivalent to the expected term of the stock option grants. The Company intends to continue to consistently apply this process using the same or similar public companies until a sufficient amount of historical information regarding the volatility of the Company's own common stock share price becomes available.

*Expected dividend yield.* Prior to 2015, the Company had never declared or paid a cash dividend. Consequently, the Company used an expected dividend yield of zero for all option grants prior to 2015.



**BENTLEY SYSTEMS, INCORPORATED AND SUBSIDIARIES**

**Notes to Consolidated Financial Statements (Continued)**  
**(in thousands, except share and per share data)**

**Note 14: Equity Awards and Instruments (Continued)**

In February 2015, the Company's board of directors established a policy to pay a quarterly dividend with the first such quarterly dividend paid in June 2015. While the Company intends to continue paying quarterly dividends, any future determination and amount per share will be subject to the discretion of the Company's board of directors and will be dependent on a number of factors, including the Company's operating results, capital requirements, restrictions under Delaware law, and overall financial conditions, as well as any other factors the Company's board of directors considers relevant.

*Expected term.* The expected term represents the period that the Company's stock-based awards are expected to be outstanding. The expected term is based on the simplified method, which represents the average period from vesting to the expiration of the award.

*Risk-free rate.* The risk-free interest rate is based on the yields of U.S. Treasury securities with maturities similar to the expected term of the options for each option group.

	Year Ended December 31,	
	2018	2019
Expected volatility	26.32% – 27.18%	29.57%
Expected dividend yield	1.18%	1.38%
Risk-free interest rate	2.40%	2.48%
Expected term (in years)	3.75	3.75
Weighted average grant date fair value of options issued	\$1.46	\$ 1.66

The fair value of the common stock was determined by the board of directors at each award grant date based upon a variety of factors, including the results obtained from independent third-party valuations, the Company's financial position, and historical financial performance.

The Company paid \$8,571 and \$8,838 during the years ended December 31, 2018 and 2019, respectively, to stockholders who exercised their options and elected to sell the shares back to the Company after the mandatory six-month holding period.

**Note 15: Income Taxes**

The components of income before income taxes consist of the following:

	Year Ended December 31,	
	2018	2019
Domestic	\$ 56,426	\$ 61,691
International	56,436	66,418
Income before income taxes	<u>\$112,862</u>	<u>\$128,109</u>

## BENTLEY SYSTEMS, INCORPORATED AND SUBSIDIARIES

Notes to Consolidated Financial Statements (Continued)  
(in thousands, except share and per share data)

## Note 15: Income Taxes (Continued)

The provision for income taxes consists of the following at December 31, 2018 and 2019:

	Year Ended December 31,	
	2018	2019
Current:		
Federal	\$ 18,634	\$ 7,696
State	873	2,486
Foreign	11,303	12,824
	<u>30,810</u>	<u>23,006</u>
Deferred:		
Federal	(7,655)	2,389
State	508	412
Foreign	(52,913)	(2,069)
	<u>(60,060)</u>	<u>732</u>
Provision for income taxes	<u><u>\$(29,250)</u></u>	<u><u>\$23,738</u></u>

A reconciliation of the statutory federal income tax rate to the Company's effective income tax rate is as follows:

	Year Ended December 31,	
	2018	2019
Federal statutory rate	21.0%	21.0%
State income taxes, net of federal benefit	0.9	2.0
Permanent book/tax differences	(0.2)	0.2
Stock-based compensation	(2.4)	(2.3)
Tax credits	(3.3)	(3.6)
Foreign tax rate differential	(4.2)	(2.8)
Income tax reserves	(0.2)	0.9
Intercompany sales of certain operating assets	(41.1)	—
Net tax on foreign earnings (GILTI and FDII)	—	6.1
Other	(0.2)	(3.0)
U.S. tax reform	3.8	—
Effective income tax rate	<u><u>(25.9)%</u></u>	<u><u>18.5%</u></u>

During 2018, the Company had intercompany sales of certain intangible operating assets between its foreign subsidiaries. The sales resulted in a 2018 net tax benefit of \$46,369. The Company early adopted ASU 2016-16 as of January 1, 2018. Refer to Recently Adopted Accounting Guidance in Note 2.

The following is a summary of the significant components of the Company's deferred tax assets and liabilities:

## BENTLEY SYSTEMS, INCORPORATED AND SUBSIDIARIES

Notes to Consolidated Financial Statements (Continued)  
(in thousands, except share and per share data)

## Note 15: Income Taxes (Continued)

	As of December 31,	
	2018	2019
Deferred tax assets:		
Compensation accruals and DCP	\$37,816	\$36,195
NOL and credit carryforwards	10,013	11,544
Intangible assets including goodwill	15,199	10,371
Expenses not currently deductible	581	960
Allowance for accounts receivable	345	472
Other comprehensive income	195	394
Deferred revenue	8,185	—
Valuation allowance	(2,082)	(2,329)
Other	615	40
	<u>70,867</u>	<u>57,647</u>
Deferred tax liabilities:		
Deferred revenue	—	12,830
Depreciation	240	707
Other	31	1,302
	<u>271</u>	<u>14,839</u>
Net deferred tax assets	<u>\$70,596</u>	<u>\$42,808</u>

The federal net operating loss (“NOL”) carryforwards with a future benefit of \$424 expire in 2033 through 2036. The Canadian credit carryforwards of \$801 have an indefinite carryforward. The Company’s state NOL carryforwards and state credit carryforwards with a future benefit of \$867 expire in 2020 through 2039. In addition, the Company has foreign NOL and credit carryforwards with a future benefit of \$7,436 (net of a \$2,016 valuation allowance), which predominately have indefinite expirations.

Some transactions can change the aggregate ownership of certain stockholders, which could cause a shift in the ownership of the Company, which pursuant to Internal Revenue Code (“IRC”) Section 382 could then limit on an annual basis the Company’s ability to utilize its U.S. federal NOL carryforwards (and possibly its state NOL carryforwards as well). If that occurred, the Company’s NOL carryforwards would continue to be available to offset taxable income and tax liabilities in future years (until such NOL carryforwards are either used or expire) subject to any IRC Section 382 annual limitation.

The Company regularly assesses the need for a valuation allowance against its deferred tax assets by considering both positive and negative evidence related to whether it is more likely than not that the deferred tax assets will be realized. In evaluating the need for a valuation allowance, the Company considers a cumulative loss in recent years as a significant piece of negative evidence.

As of December 31, 2018 and 2019, the Company has recorded a valuation allowance against its net deferred tax assets of \$2,082 and \$2,329, respectively. The valuation allowance is principally related to the U.K. net operating losses for which the Company has determined that realization is not more likely than not.

On December 22, 2017, the Act was enacted. U.S. tax reform, among other things, reduces the U.S. federal income tax rate to 21% from 35% in 2018, institutes a dividends received deduction for foreign earnings with a related tax for the deemed repatriation of unremitted foreign earnings, and creates a new U.S. minimum tax on earnings of foreign subsidiaries. The Company completed its accounting for the effects

**BENTLEY SYSTEMS, INCORPORATED AND SUBSIDIARIES**

**Notes to Consolidated Financial Statements (Continued)**  
**(in thousands, except share and per share data)**

**Note 15: Income Taxes (Continued)**

of the Act in 2018 and has included those effects in *Provision for income taxes* in the consolidated statement of operations. The Company will elect to pay the liability for the deemed repatriation of foreign earnings in installments, as specified by the Act.

Additionally, the Act requires certain Global Intangible Low-Taxed Income (“GILTI”) earned by a controlled foreign corporation (“CFC”) to be included in the gross income of the CFC’s U.S. shareholder. The Company has elected the “period cost method” and treats taxes due on future U.S. inclusions in taxable income related to GILTI as a current-period expense when incurred. The Act allows a U.S. corporation a deduction equal to a certain percentage of its foreign-derived intangible income (“FDII”). The Company estimated the impact of the GILTI tax and FDII deduction in determining its 2019 annual effective tax rate that is reflected in its provision for income taxes for the year ended December 31, 2019.

As of December 31, 2019, the Company has accumulated undistributed earnings generated by its foreign subsidiaries of approximately \$408,582, of which \$359,724 was subject to the one-time transition tax on foreign earnings required by the Act and the tax on GILTI. The Company intends to indefinitely reinvest these earnings, as well as future earnings from its foreign subsidiaries, in order to fund its international operations. In addition, the Company expects future U.S. cash generation will be sufficient to meet future U.S. cash needs. The Company has not provided for any additional outside basis difference inherent in its foreign subsidiaries, as these amounts continue to be indefinitely reinvested in foreign operations. Determining the amount of unrecognized deferred tax liability related to any additional outside basis difference in these entities is not practicable.

In accordance with the indefinite reversal criteria, the foreign currency translation adjustments recorded in other comprehensive loss related to the foreign currency translations have not been tax effected.

The following is a reconciliation of the total amounts of unrecognized tax benefits:

	Year Ended December 31,	
	2018	2019
Unrecognized tax benefit, beginning of year	\$ 872	\$ 638
Additions based on tax positions related to:		
Prior years	80	1,222
Reductions for tax positions related to prior years	(39)	(86)
Lapse of statute of limitations	(275)	(11)
Unrecognized tax benefit, end of year	<u>\$ 638</u>	<u>\$1,763</u>

The amount of unrecognized tax benefits at December 31, 2018 and 2019 was \$638 and \$1,763, respectively, of which \$627 and \$1,733 would impact the Company’s effective tax rate if recognized. In the years ended December 31, 2018 and 2019, interest expense and penalties related to income taxes resulted in an income tax expense of \$8 and \$101, respectively. Interest expense and penalties are included in *Provision for income taxes* in the consolidated statements of operations. Accrued interest and penalties as of December 31, 2018 and 2019 totaled \$252 and \$362, respectively. The Company records the amount of uncertain taxes expected to be paid in the next 12 months as a current liability and records the remaining amount as a non-current liability in the accompanying consolidated balance sheets.

The Company is subject to income tax in the United States as well as numerous state and foreign jurisdictions. The Company is currently under audit in the U.K. for years 2014 through 2017. The Company believes that an adequate provision has been made for any adjustment that may result from the tax examination. The Company’s 2017 through 2019 tax years remain subject to examination by the Irish

**BENTLEY SYSTEMS, INCORPORATED AND SUBSIDIARIES****Notes to Consolidated Financial Statements (Continued)**  
**(in thousands, except share and per share data)****Note 15: Income Taxes (Continued)**

Revenue Commissioners for Irish tax purposes. The Company's 2017 through 2019 tax years remain subject to examination by the IRS. In addition, the Company is under audit in various other foreign taxing jurisdictions that are not material to the consolidated financial statements.

**Note 16: Fair Value of Financial Instruments*****Derivatives Not Designated As Hedging Instrument***

In November 2018, the Company entered into an agreement with financial institutions to purchase call options to buy British pounds ("GBP") with a notional amount of 65,000 GBP at a strike price of \$1.375. The call options were purchased at a premium of \$645. These derivative instruments do not qualify for hedge accounting and as such, are not designated as hedges. The gains or losses from changes in the fair value of such derivative instruments are recognized in *Other income (expense), net* in the consolidated statements of operations. The fair value of the call options in the accompanying consolidated balance sheets was \$158 and \$0 as of December 31, 2018 and 2019, respectively. The call options had an expiration date of February 28, 2019.

***Fair Value***

The Company applies the provisions of ASC Topic 820, *Fair Value Measurement*, for fair value measurements of financial assets and financial liabilities and for fair value measurements of non-financial items that are recognized or disclosed at fair value in the consolidated financial statements.

The Company's financial instruments include cash equivalents, account receivables, certain other assets, accounts payable, accruals, other current liabilities, and long-term debt.

The carrying values of the Company's financial instruments excluding long-term debt approximate their fair value due to the short-term nature of those instruments. Additionally, as of December 31, 2018 and 2019, the fair value of the Company's long-term debt approximated its carrying value based upon discounted cash flows at current market rates for instruments with similar remaining terms. The Company considers these valuation inputs to be Level 2 inputs in the fair value hierarchy. Considerable judgment is necessary to interpret the market data and develop estimates of fair values. Accordingly, the estimates presented are not necessarily indicative of the amounts at which these instruments could be purchased, sold, or settled.

A financial asset or liability classification is determined based on the lowest level input that is significant to the fair value measurement. The fair value hierarchy consists of the following three levels:

Level 1 inputs are quoted prices (unadjusted) in active markets for identical assets or liabilities.

Level 2 inputs are quoted prices for similar assets and liabilities in active markets or inputs that are observable for the asset or liability, either directly or indirectly through market corroboration, for substantially the full term of the financial instrument.

Level 3 inputs are unobservable inputs based on management's own assumptions used to measure assets and liabilities at fair value.

## BENTLEY SYSTEMS, INCORPORATED AND SUBSIDIARIES

Notes to Consolidated Financial Statements (Continued)  
(in thousands, except share and per share data)

## Note 16: Fair Value of Financial Instruments (Continued)

The following tables provide the financial assets and financial liabilities carried at fair value measured on a recurring basis:

December 31, 2018	Level 1	Level 2	Level 3	Total
<b>Assets:</b>				
Money market funds <sup>(1)</sup>	\$30,197	\$ —	\$ —	\$30,197
Call options <sup>(2)</sup>	—	158	—	158
<b>Total assets</b>	<b>\$30,197</b>	<b>\$158</b>	<b>\$ —</b>	<b>\$30,355</b>
<b>Liabilities:</b>				
Acquisition contingent consideration <sup>(3)</sup>	\$ —	\$ —	\$4,316	\$ 4,316
Deferred compensation plan <sup>(4)</sup>	2,275	—	—	2,275
<b>Total liabilities</b>	<b>\$ 2,275</b>	<b>\$ —</b>	<b>\$4,316</b>	<b>\$ 6,591</b>
December 31, 2019	Level 1	Level 2	Level 3	Total
<b>Assets:</b>				
Money market funds <sup>(1)</sup>	\$70,000	\$—	\$ —	\$70,000
<b>Total assets</b>	<b>\$70,000</b>	<b>\$—</b>	<b>\$ —</b>	<b>\$70,000</b>
<b>Liabilities:</b>				
Acquisition contingent consideration <sup>(3)</sup>	\$ —	\$—	\$6,599	\$ 6,599
Deferred compensation plan <sup>(4)</sup>	2,544	—	—	2,544
<b>Total liabilities</b>	<b>\$ 2,544</b>	<b>\$—</b>	<b>\$6,599</b>	<b>\$ 9,143</b>

- (1) Included in *Cash and cash equivalents* in the accompanying consolidated balance sheets.
- (2) Included in *Other assets* in the accompanying consolidated balance sheets.
- (3) Included in *Accruals and other current liabilities* and *Other liabilities* in the accompanying consolidated balance sheets. Acquisition contingent consideration liability is measured at fair value and is based on significant inputs not observable in the market, which represents a Level 3 measurement within the fair value hierarchy. The valuation of contingent consideration uses assumptions the Company believes would be made by a market participant.
- (4) Included in *Other liabilities*, except for current liabilities of \$115 and \$153 as of December 31, 2018 and 2019, respectively, which is included in *Accruals and other current liabilities* in the accompanying consolidated balance sheets.

The following table is a reconciliation of the changes in fair value of the Company's financial liabilities which have been classified as Level 3 in the fair value hierarchy for the years ended December 31, 2018 and 2019.

	Year Ended December 31,	
	2018	2019
Balance, beginning of year	\$ 241	\$ 4,316
Payments	(9)	(2,513)
Addition	13,206	4,498

## BENTLEY SYSTEMS, INCORPORATED AND SUBSIDIARIES

Notes to Consolidated Financial Statements (Continued)  
(in thousands, except share and per share data)

## Note 16: Fair Value of Financial Instruments (Continued)

	Year Ended December 31,	
	2018	2019
Reclassification <sup>(1)</sup>	(8,516)	180
Change in fair value	167	62
Foreign currency translation adjustments	(773)	56
Balance, end of year	<u>\$ 4,316</u>	<u>\$ 6,599</u>

- (1) One of the 2018 acquisitions requires the Company to pay former shareholders a revenue based earn-out contingent on meeting certain 2018 revenue targets. As of December 31, 2018, such revenue targets were met and as a consequence \$8,516 was reclassified to non-contingent consideration from acquisitions within *Accruals and other current liabilities*.

The Company did not have any transfers between levels within the fair value hierarchy.

## Note 17: Commitments and Contingencies

**Purchase Commitment**—In the normal course of business, the Company enters into various purchase commitments for goods and services. As of December 31, 2018, the non-cancellable future cash purchase commitment for services related to the provisioning of our software solutions was \$15,377 through June 2020. As of December 31, 2019, such commitment was fully consumed.

**Operating Leases**—The Company leases certain facilities, cars, and equipment under operating leases having initial or remaining non-cancellable terms in excess of one year.

The future minimum lease payments for the years following December 31, 2019 are as follows:

2020	\$15,886
2021	13,186
2022	10,385
2023	6,572
2024	3,216
Thereafter	2,771
	<u>\$52,016</u>

Rent expense is recorded on straight-line basis over the life of the lease. During the years ended December 31, 2018 and 2019, total rent expense was \$16,726 and \$17,036, respectively.

**Litigation**—From time to time, the Company is involved in certain legal actions arising in the ordinary course of business. In management's opinion, based upon the advice of counsel, the outcome of such actions is not expected to have a material adverse effect on the Company's future financial position or results of operations.

## Note 18: Geographic Data

Revenues by geographic area are presented as part of the discussion in Note 3. The following table presents the Company's long-lived assets, net of depreciation and amortization by geographic region. See Note 5 and Note 6.

## BENTLEY SYSTEMS, INCORPORATED AND SUBSIDIARIES

Notes to Consolidated Financial Statements (Continued)  
(in thousands, except share and per share data)

## Note 18: Geographic Data (Continued)

	Year Ended December 31,	
	2018	2019
Long-lived assets:		
Americas <sup>(1)</sup>	\$32,490	\$34,758
Europe, the Middle East, and Africa	43,933	34,039
Asia/Pacific	6,971	7,148
Total long-lived assets	<u>\$83,394</u>	<u>\$75,945</u>

(1) Americas includes the United States, Canada, and Latin America (including the Caribbean).

## Note 19: Interest Expense, Net

Interest expense, net is comprised of the following:

	Year Ended December 31,	
	2018	2019
Interest expense	\$(9,607)	\$(9,731)
Interest income	842	1,532
Total interest expense, net	<u>\$(8,765)</u>	<u>\$(8,199)</u>

## Note 20: Other Income (Expense), Net

Other income (expense), net is comprised of the following:

	Year Ended December 31,	
	2018	2019
Foreign exchange loss <sup>(1)</sup>	\$(418)	\$(5,591)
Other income (expense), net <sup>(2)</sup>	654	34
Total other income (expense), net	<u>\$ 236</u>	<u>\$(5,557)</u>

- (1) Foreign exchange loss is primarily attributable to foreign currency translation losses derived primarily from U.S. Dollar denominated cash and cash equivalents, account receivables, and intercompany balances held by foreign subsidiaries. For the year ended December 31, 2018, the foreign exchange loss includes a loss of \$487 relating to the remeasurement of a derivative instrument (see Note 16). In October 2018, the Company had intercompany sales of certain intangible operating assets between foreign subsidiaries, which resulted in significant U.S. dollar denominated finance transactions and balances between certain of its foreign subsidiaries. For the year ended December 31, 2019, such finance transactions resulted in unrealized foreign currency translation losses of \$5,270.
- (2) For the year ended December 31, 2018, other income (expense), net includes a gain of \$707 relating to insurance proceeds received in excess of the net book value of the replaced assets.

## Note 21: Realignment Costs

During 2015, the Company initiated a strategic realignment program in order to better serve the Company's users and to better align resources with the evolving needs of the business. The Company



## BENTLEY SYSTEMS, INCORPORATED AND SUBSIDIARIES

Notes to Consolidated Financial Statements (Continued)  
(in thousands, except share and per share data)**Note 21: Realignment Costs (Continued)**

incurred total realignment costs of \$6,778 and \$(584) for the years ended December 31, 2018 and 2019, respectively. As of December 31, 2018 and 2019, accrued realignment costs totaled \$6,437 and \$491 and are included in *Accruals and other current liabilities* in the consolidated balance sheets.

The following table sets forth realignment activity during the years ended December 31, 2018 and 2019:

	Year Ended December 31,	
	2018	2019
Balance, beginning of year	\$ 1,458	\$ 6,437
Realignment costs	6,778	(584)
Payments	(1,640)	(5,326)
Adjustments <sup>(1)</sup>	(159)	(36)
Balance, end of year	<u>\$ 6,437</u>	<u>\$ 491</u>

(1) Adjustments includes foreign currency translation.

The following table sets forth the realignment costs by expense classification for the years ended December 31, 2018 and 2019:

	Year Ended December 31,	
	2018	2019
<b>Cost of revenues:</b>		
Cost of subscriptions and licenses	\$ 256	\$ (51)
Cost of services	845	(185)
Total cost of revenues	<u>1,101</u>	<u>(236)</u>
<b>Operating expenses:</b>		
Research and development	3,380	(171)
Selling and marketing	2,252	(263)
General and administrative	45	86
Total operating expenses	<u>5,677</u>	<u>(348)</u>
Total realignment costs	<u>\$6,778</u>	<u>\$(584)</u>

**Note 22: Earnings Per Share**

Earnings per share ("EPS") of Class A and Class B Common Stock amounts are computed using the two-class method required for participating securities. The Company issues certain restricted stock awards determined to be participating securities because holders of such shares have non-forfeitable dividend rights in the event of the Company's declaration of a dividend for common shares.

Undistributed earnings allocated to participating securities are subtracted from net income in determining net income attributable to common stockholders. Basic EPS is computed by dividing net income attributable to common stockholders by the weighted-average number of shares of Class A and Class B Common Stock outstanding.

For the calculation of diluted EPS, net income attributable to common stockholders for basic EPS is adjusted by the effect of dilutive securities, including awards under the Company's equity compensation

**BENTLEY SYSTEMS, INCORPORATED AND SUBSIDIARIES**

**Notes to Consolidated Financial Statements (Continued)**  
**(in thousands, except share and per share data)**

**Note 22: Earnings Per Share (Continued)**

plans. Diluted EPS attributable to common stockholders is computed by dividing the resulting net income attributable to common stockholders by the weighted-average number of fully diluted common shares outstanding.

Except with respect to voting and conversion, the rights of the holders of the Company's Class A Common Stock and the Company's Class B Common Stock are identical. Each class of shares has the same rights to dividends and allocation of income (loss) and therefore, earnings per share would not differ under the two-class method. The details of basic and diluted EPS are as follows (in thousands, except per share amounts):

	Year Ended December 31,	
	2018	2019
<b>Numerator:</b>		
Net income	\$ 142,112	\$ 103,096
Less: Net income attributable to participating securities	(4)	(8)
Net income attributable to Class A and Class B common stockholders	<u>\$ 142,108</u>	<u>\$ 103,088</u>
<b>Denominator:</b>		
Denominator for basic net income per share – weighted average shares	285,805,096	284,625,642
Effect of dilutive securities:		
Stock options	6,819,400	9,171,065
Denominator for dilutive net income per share	<u>292,624,496</u>	<u>293,796,707</u>
<b>Net income per share, basic</b>	<u>\$ 0.50</u>	<u>\$ 0.36</u>
<b>Net income per share, diluted</b>	<u>\$ 0.49</u>	<u>\$ 0.35</u>

No shares were excluded from the computation of diluted net income per share attributable to common stockholders for the periods presented.

**Note 23: Subsequent Events**

In preparing the consolidated financial statements as of and for the years ended December 31, 2018 and 2019, the Company evaluated subsequent events for recognition and measurement through March 6, 2020, the date when the consolidated financial statements were issued.

## BENTLEY SYSTEMS, INCORPORATED AND SUBSIDIARIES

**Consolidated Balance Sheets**  
(in thousands, except share and per share data) (unaudited)

	December 31, 2019	June 30, 2020	Pro Forma June 30, 2020
<b>Assets</b>			
Current assets:			
Cash and cash equivalents	\$ 121,101	\$ 125,516	\$ 125,516
Accounts receivable	211,775	169,778	169,778
Allowance for doubtful accounts	(7,274)	(7,272)	(7,272)
Prepaid income taxes	4,543	6,501	6,501
Prepaid and other current assets	23,413	23,560	23,560
Total current assets	353,558	318,083	318,083
Property and equipment, net	29,632	30,303	30,303
Operating lease right-of-use assets	—	48,134	48,134
Intangible assets, net	46,313	50,008	50,008
Goodwill	480,065	529,759	529,759
Investment in joint venture	1,725	859	859
Deferred income taxes	51,068	45,218	45,218
Other assets	32,238	36,805	36,805
Total assets	<u>\$994,599</u>	<u>\$1,059,169</u>	<u>\$1,059,169</u>
<b>Liabilities and Stockholders' Equity (Deficit)</b>			
Current liabilities:			
Accounts payable	\$ 17,669	\$ 19,294	\$ 19,294
Accruals and other current liabilities	167,517	174,889	176,333
Deferred revenues	204,991	180,130	180,130
Operating lease liabilities	—	15,959	15,959
Income taxes payable	2,236	3,666	3,666
Total current liabilities	392,413	393,938	395,382
Long-term debt	233,750	207,000	596,583
Long-term operating lease liabilities	—	34,182	34,182
Deferred revenues	8,154	6,326	6,326
Deferred income taxes	8,260	9,228	9,228
Income taxes payable	8,140	8,140	8,140
Other liabilities	9,263	20,611	22,356
Total liabilities	<u>659,980</u>	<u>679,425</u>	<u>1,072,197</u>
Commitments and contingencies (Note 18)			
Stockholders' equity (deficit):			
Class A Common Stock, \$0.01 par value, authorized 320,000,000 shares; issued 11,601,757 shares as of December 31, 2019 and June 30, 2020, actual and pro forma, and Class B Common Stock, \$0.01 par value, authorized 600,000,000 shares; issued 243,241,192 and 247,607,598 shares as of December 31, 2019 and June 30, 2020, actual and pro forma, respectively	2,548	2,592	2,592
Additional paid-in capital	408,667	415,883	415,883
Accumulated other comprehensive loss	(23,927)	(28,404)	(28,404)
Accumulated deficit	(52,669)	(10,327)	(403,099)
Total stockholders' equity (deficit)	<u>334,619</u>	<u>379,744</u>	<u>(13,028)</u>
Total liabilities and stockholders' equity (deficit)	<u>\$994,599</u>	<u>\$1,059,169</u>	<u>\$1,059,169</u>

See accompanying notes to consolidated financial statements.

## BENTLEY SYSTEMS, INCORPORATED AND SUBSIDIARIES

**Consolidated Statements of Operations**  
(in thousands, except share and per share data) (unaudited)

	Six Months Ended June 30,	
	2019	2020
<b>Revenues:</b>		
Subscriptions	\$ 290,147	\$ 327,837
Perpetual licenses	24,468	23,193
Subscriptions and licenses	314,615	351,030
Services	32,529	27,950
Total revenues	347,144	378,980
<b>Cost of revenues:</b>		
Cost of subscriptions and licenses	30,831	43,128
Cost of services	38,367	30,836
Total cost of revenues	69,198	73,964
Gross profit	277,946	305,016
<b>Operating expenses:</b>		
Research and development	91,861	89,353
Selling and marketing	75,168	65,727
General and administrative	46,307	52,269
Amortization of purchased intangibles	6,852	7,115
Total operating expenses	220,188	214,464
Income from operations	57,758	90,552
Interest expense, net	(4,474)	(2,516)
Other income (expense), net	(1,747)	(6,985)
Income before income taxes	51,537	81,051
Provision for income taxes	5,119	11,440
Equity in loss of joint venture, net of tax	—	866
Net income	46,418	68,745
Less: Net income attributable to participating securities	(12)	—
Net income attributable to Class A and Class B common stockholders	\$ 46,406	\$ 68,745
<b>Per share information:</b>		
Net income per share, basic	\$ 0.16	\$ 0.24
Net income per share, diluted	\$ 0.16	\$ 0.23
Weighted average shares outstanding, basic	285,529,476	286,068,766
Weighted average shares outstanding, diluted	293,633,255	295,595,234

See accompanying notes to consolidated financial statements.

**BENTLEY SYSTEMS, INCORPORATED AND SUBSIDIARIES****Consolidated Statements of Comprehensive Income  
(in thousands) (unaudited)**

	Six Months Ended June 30,	
	2019	2020
Net income	\$46,418	\$68,745
Other comprehensive income (loss), net of taxes:		
Foreign currency translation adjustments	2,406	(4,503)
Actuarial gain on retirement plan, net of tax effect of (\$6) and (\$15), respectively	10	26
Total other comprehensive income (loss), net of taxes	2,416	(4,477)
Comprehensive income	<u>\$48,834</u>	<u>\$64,268</u>

See accompanying notes to consolidated financial statements.

## BENTLEY SYSTEMS, INCORPORATED AND SUBSIDIARIES

**Consolidated Statements of Stockholders' Equity**  
**(in thousands, except share and per share data) (unaudited)**

	Stockholders' Equity					
	Class A and Class B Common Stock		Additional paid-in capital	Accumulated other comprehensive loss	Accumulated deficit	Total stockholders' equity
	Shares	Par value				
Balance as of December 31, 2018	250,283,513	\$2,502	\$ 392,896	\$ (29,414)	\$(218,553)	\$ 147,431
Cumulative effect of accounting changes	—	—	—	—	107,822	107,822
Net income	—	—	—	—	46,418	46,418
Other comprehensive income (loss)	—	—	—	2,416	—	2,416
Dividends declared	—	—	—	—	(12,643)	(12,643)
Profit sharing plan shares, net	(160,963)	(2)	—	—	(1,211)	(1,213)
Shares issued in connection with deferred compensation plan, net	2,230,430	22	—	—	(4,975)	(4,953)
Deferred compensation plan voluntary contributions and vesting of awards	—	—	1,876	—	—	1,876
Payment of shareholder Put and Call rights	(401,352)	(4)	—	—	(3,145)	(3,149)
Common Stock Purchase Agreement, net	64,509	1	466	—	(47)	420
Stock option exercises, net	2,657,027	27	2,154	—	(2,150)	31
Stock-based compensation expense	—	—	4,025	—	—	4,025
Shares related to restricted stock, net	409,665	4	(4)	—	(169)	(169)
Other	3,563	—	26	—	(17)	9
Balance as of June 30, 2019	<u>255,086,392</u>	<u>\$2,550</u>	<u>\$ 401,439</u>	<u>\$ (26,998)</u>	<u>\$( 88,670)</u>	<u>\$288,321</u>

See accompanying notes to consolidated financial statements.

## BENTLEY SYSTEMS, INCORPORATED AND SUBSIDIARIES

**Consolidated Statements of Stockholders' Equity**  
**(in thousands, except share and per share data) (unaudited)**

	Stockholders' Equity					
	Class A and Class B Common Stock		Additional paid-in capital	Accumulated other comprehensive loss	Accumulated deficit	Total stockholders' equity
	Shares	Par value				
Balance as of December 31, 2019	254,842,949	\$2,548	\$408,667	\$ (23,927)	\$ (52,669)	\$334,619
Net income	—	—	—	—	68,745	68,745
Other comprehensive income (loss)	—	—	—	(4,477)	—	(4,477)
Dividends declared	—	—	—	—	(15,437)	(15,437)
Profit sharing plan shares, net	(385,568)	(4)	—	—	(4,424)	(4,428)
Shares issued in connection with deferred compensation plan, net	2,959,731	30	—	—	(1,860)	(1,830)
Deferred compensation plan voluntary contributions	—	—	1,798	—	—	1,798
Payment of shareholder Put and Call rights	(128,176)	(1)	—	—	(1,453)	(1,454)
Common Stock Purchase Agreement, net	169	—	—	—	(57)	(57)
Stock option exercises, net	2,184,628	22	2,203	—	(3,052)	(827)
Shares issued for stock grants, net	17,411	—	219	—	—	219
Stock-based compensation expense	—	—	2,993	—	—	2,993
Shares related to restricted stock, net	(281,789)	(3)	3	—	(120)	(120)
Balance as of June 30, 2020	<u>259,209,355</u>	<u>\$2,592</u>	<u>\$415,883</u>	<u>\$ (28,404)</u>	<u>\$ (10,327)</u>	<u>\$379,744</u>

See accompanying notes to consolidated financial statements.

## BENTLEY SYSTEMS, INCORPORATED AND SUBSIDIARIES

**Consolidated Statements of Cash Flows**  
(in thousands, except share and per share data) (unaudited)

	Six Months Ended June 30,	
	2019	2020
Cash flows from operating activities:		
Net income	\$ 46,418	\$ 68,745
Adjustments to reconcile net income to net cash provided by operating activities:		
Depreciation and amortization	15,366	16,664
Provision for accounts receivable allowance	1,088	293
Deferred income taxes	(2,354)	5,284
Deferred compensation plan activity	2,171	1,633
Stock-based compensation expense	4,025	3,212
Amortization of deferred debt issuance costs	277	277
Change in fair value of derivative	159	4,174
Change in fair value of contingent consideration	62	(1,390)
Foreign currency remeasurement loss	1,230	3,538
Equity in loss of joint venture, net of tax	—	866
Changes in assets and liabilities, net of effect from acquisitions:		
Accounts receivable, net	39,856	44,263
Prepaid and other assets	(7,497)	9,089
Accounts payable, accruals and other liabilities	19,447	11,208
Deferred revenues	(25,326)	(29,500)
Income taxes payable	(12,164)	(2,174)
Net cash provided by operating activities	<u>82,758</u>	<u>136,182</u>
Cash flows from investing activities:		
Purchases of property and equipment and investment in capitalized software	(8,123)	(9,419)
Capitalization of costs to translate software products into foreign languages	(372)	(551)
Acquisitions, net of cash acquired of \$980 and \$2,064, respectively	(9,662)	(67,595)
Other investing activities	—	(1,414)
Net cash used in investing activities	<u>(18,157)</u>	<u>(78,979)</u>
Cash flows from financing activities:		
Proceeds from credit facilities	84,000	164,375
Payments of credit facilities	(95,750)	(191,125)
Payments of financing leases	—	(93)
Payments of acquisition debt and other consideration	(8,273)	(1,091)
Payments of dividends	(12,641)	(15,901)
Payments for shares acquired including shares withheld for taxes	(16,027)	(69,307)
Proceeds from Common Stock Purchase Agreement	4,510	58,349
Net proceeds from exercise of common stock options and restricted stock	2,177	2,237
Net cash used in financing activities	<u>(42,004)</u>	<u>(52,556)</u>
Effect of exchange rate changes on cash and cash equivalents	(346)	(232)
Increase in cash and cash equivalents	22,251	4,415
Cash and cash equivalents, beginning of year	81,183	121,101
Cash and cash equivalents, end of period	<u>\$103,434</u>	<u>\$ 125,516</u>
Supplemental information:		
Cash paid for income taxes	\$ 21,931	\$ 7,180
Income tax refunds	1,000	298
Interest paid	4,909	3,162
Non-cash contingent acquisition consideration	50	1,706
Non-cash deferred acquisition consideration	—	1,069

See accompanying notes to consolidated financial statements.



**BENTLEY SYSTEMS, INCORPORATED AND SUBSIDIARIES****Notes to Consolidated Financial Statements  
(in thousands, except share and per share data) (unaudited)****Note 1: Basis of Presentation and Significant Accounting Policies**

**Description of Business and Operations**— Bentley Systems, Incorporated (“Bentley” or the “Company”) is a Delaware corporation that was founded in 1984 and is headquartered in Exton, Pennsylvania. The Company, together with its subsidiaries, is a leading global provider of infrastructure engineering software solutions for professionals and organizations involved in the project delivery and operational performance of infrastructure assets. The Company is dedicated to advancing infrastructure through its comprehensive software solutions that span engineering disciplines, assets, and lifecycle processes. The Company’s integrated software platform encompasses both the design and construction of infrastructure, which the Company refers to as project delivery, and the operation of infrastructure assets, which the Company refers to as asset performance. The Company’s software solutions are designed to enable information mobility for a more complete flow of information among applications, across distributed project teams, from offices to the field, and throughout the infrastructure lifecycle. The Company believes its solutions extend the reach and scope of digital engineering models from the project delivery phase into the asset performance phase of the infrastructure lifecycle, which enables engineers to make infrastructure assets more intelligent and sustainable. Users of the Company’s solutions include engineers and construction professionals who collaborate on project delivery, and owner-operators who maintain, adapt, and optimize the performance of infrastructure assets.

**Basis of Presentation and Consolidation**— The unaudited consolidated financial statements and accompanying notes have been prepared in United States (“U.S.”) dollars and in accordance with accounting principles generally accepted in the United States of America (“U.S. GAAP”). The accompanying consolidated financial statements include the accounts of the Company and its wholly-owned subsidiaries. The Company is party to a joint venture which is accounted for using the equity method. All significant intercompany accounts and transactions have been eliminated in consolidation. In the opinion of management, the accompanying unaudited consolidated financial statements contain all adjustments, consisting only of those of a normal recurring nature, necessary for a fair statement of our financial position, results of operations, and cash flows at the dates and for the periods indicated. The December 31, 2019 consolidated balance sheet included herein is derived from our audited consolidated financial statements. The results of operations for the six months ended June 30, 2020 are not necessarily indicative of the results expected for the remainder of the fiscal year.

The Company’s principal subsidiaries are Bentley Systems International Limited (Ireland), Bentley Software International, Limited (Bermuda), Bentley Canada Inc. (Canada), Bentley Systems Europe BV (the Netherlands), Bentley Systems Pty Ltd. (Australia), Bentley Systems Co., Ltd. (Japan), Bentley Systems Germany GmbH (Germany), Bentley Systems Ltd. (UK), and Bentley Systems India Private Limited (India).

**Use of Estimates**— The preparation of consolidated financial statements and related disclosures in conformity with U.S. GAAP requires management to make estimates and assumptions that affect the reported amounts of assets and liabilities and disclosure of contingent assets and liabilities at the dates of the financial statements and the reported amounts of revenues and expenses during the reporting periods. The Company’s significant estimates and assumptions include revenue recognition, adequacy of allowance for accounts receivable, determination of the fair value of acquired assets and liabilities, the fair value of derivative financial instruments, the fair value of common stock and stock-based compensation, operating lease assets and liabilities, useful lives for depreciation and amortization, impairment of goodwill and intangible assets, and accounting for income taxes. Actual results could differ materially from these estimates.

**Derivatives Not Designated As Hedging Instruments**— On March 31, 2020, the Company entered into an interest rate swap with a notional amount of \$200,000 and a ten-year term to reduce the interest rate risk associated with the Company’s Credit Facility (see Note 10). The interest rate swap is not designated as a hedging instrument for accounting purposes. The Company accounts for the swap as either an asset or a liability on the consolidated balance sheet and carries the derivative at fair value. Gains and losses from the

**BENTLEY SYSTEMS, INCORPORATED AND SUBSIDIARIES**

**Notes to Consolidated Financial Statements (Continued)**  
**(in thousands, except share and per share data) (unaudited)**

**Note 1: Basis of Presentation and Significant Accounting Policies (Continued)**

change in fair value are recognized in *Other income (expense), net* and payments related to the swap are recognized in *Interest expense, net* in the consolidated statements of operations. The bank counterparty to the derivative potentially exposes the Company to credit-related losses in the event of nonperformance. To mitigate that risk, the Company only contracts with counterparties who meet the Company's minimum requirements under its counterparty risk assessment process. The Company monitors counterparty risk on at least a quarterly basis and adjusts its exposure as necessary. The Company does not enter into derivative instrument transactions for trading or speculative purposes.

**Leases**—The Company determines if an arrangement is a lease at inception. Operating leases are included in *Operating lease right-of-use assets*, *Operating lease liabilities*, and *Long-term operating lease liabilities* in the Company's consolidated balance sheets. Operating lease right-of-use assets represent the Company's right to use an underlying asset for the lease term and operating lease liabilities represent the Company's obligation to make lease payments arising from the lease. Operating lease right-of-use assets and operating lease liabilities are recognized at the commencement date based on the present value of lease payments over the lease term. The Company uses its incremental borrowing rate, if the Company's leases do not provide an implicit rate, based on the information available at the commencement date in determining the present value of lease payments. The incremental borrowing rate is determined based on the Company's estimated credit rating, the term of the lease, economic environment where the asset resides, and full collateralization. The operating lease right-of-use assets also include any lease payments made and are reduced by any lease incentives. Options to extend or terminate the lease are considered in determining the lease term when it is reasonably certain that the option will be exercised. Lease expense for lease payments is recognized on a straight-line basis over the lease term. The Company's operating leases are primarily for office space, cars, and office equipment. Finance leases are included in *Property and equipment, net*, *Accruals and other current liabilities*, and *Other liabilities* in the Company's consolidated balance sheet.

**Significant Accounting Policies**—There have been no changes other than what is discussed herein to the Company's significant accounting policies as compared to the significant accounting policies described in Note 1 to the Company's consolidated financial statements as of and for the year ended December 31, 2019. These unaudited consolidated financial statements should be read in conjunction with the consolidated financial statements and related notes as of and for the year ended December 31, 2019.

**Unaudited Pro Forma Financial Information**—The accompanying unaudited pro forma consolidated balance sheet as of June 30, 2020 has been prepared to give effect to (i) the payment on September 2, 2020 of a special dividend of \$1.50 per share of our common stock (approximately \$390,000 in the aggregate) (the "Special Dividend") declared by the Company's board of directors on August 28, 2020 and the funding of such Special Dividend with borrowings under a \$125,000 senior secured term loan with a maturity date of December 18, 2022 (the "New Term Loan") provided for by an amendment to the Credit Facility (as defined below) and under the revolving facility under the Credit Facility and (ii) the accrual of the Special Dividend on 2,204,572 shares of outstanding restricted stock and restricted stock units.

**Note 2: Recent Accounting Pronouncements**

In August 2018, the Financial Accounting Standards Board ("FASB") issued ASU No. 2018-15, *Intangibles — Goodwill and Other — Internal-Use Software (Subtopic 350-40): Customer's Accounting for Implementation Costs Incurred in a Cloud Computing Arrangement That is a Service Contract*, which clarifies the accounting for implementation costs in cloud computing arrangements. ASU 2018-15 is effective for the Company for the annual reporting period beginning after December 15, 2020, and interim periods beginning after December 15, 2021. Early adoption is permitted, including adoption in an interim period. The Company is currently evaluating the accounting, transition, and disclosure requirements of the standard and its impact on the Company's consolidated results of operations and financial position.

**BENTLEY SYSTEMS, INCORPORATED AND SUBSIDIARIES**

**Notes to Consolidated Financial Statements (Continued)**  
**(in thousands, except share and per share data) (unaudited)**

**Note 2: Recent Accounting Pronouncements (Continued)**

In January 2017, the FASB issued ASU No. 2017-04, *Intangibles-Goodwill and Other (Topic 350): Simplifying the Test for Goodwill Impairment*, which removes Step 2 of the goodwill impairment test. A goodwill impairment will now be calculated as the amount by which a reporting unit's carrying value exceeds its fair value, not to exceed the carrying amount of goodwill. This ASU is effective for the Company for the interim and annual reporting periods beginning after December 15, 2021. Early adoption is permitted, including adoption in an interim period. The Company does not believe that this ASU will have a material impact on the Company's consolidated results of operations and financial position.

***Recently Adopted Accounting Guidance***

In February 2016, the FASB issued ASU No. 2016-02 regarding ASC Topic 842, *Leases* ("Topic 842"). This ASU requires balance sheet recognition of lease assets and lease liabilities by lessees for leases classified as operating leases, with an optional policy election to not recognize lease assets and lease liabilities for leases with a term of 12 months or less. The amendments also require new disclosures, including qualitative and quantitative requirements, providing additional information about the amounts recorded in the financial statements. Subsequent to the issuance of ASU 2016-02, the FASB issued ASU Nos. 2018-01, *Land Easement Practical Expedient for Transition to Topic 842*, 2018-10, *Codification Improvements to Topic 842, Leases*, 2018-11, *Leases (Topic 842): Targeted Improvements*, and 2018-20, *Narrow-Scope Improvements for Lessors*. These ASUs do not change the core principle of the guidance in ASU 2016-02. Instead, these amendments are intended to clarify and improve operability of certain topics included within the lease standard.

The Company adopted Topic 842 as of January 1, 2020 using the modified retrospective method for all existing leases. Upon adoption, the Company recognized its lease assets and lease liabilities measured at the present value of all future fixed lease payments, discounted using the Company's incremental borrowing rate.

The Company elected the package of practical expedients as permitted under the transition guidance, which allows the Company: (1) to not reassess whether any existing contracts are leases or contain a lease; (2) to not reassess the lease classification of existing leases; and (3) to not reassess treatment of initial direct costs for existing leases. Additionally, the Company elected the practical expedients to combine lease and non-lease components for new leases post adoption and to not recognize lease assets and lease liabilities for leases with a term of 12 months or less.

Upon adoption of Topic 842, the Company recognized right of use assets of \$45,850 and lease liabilities of \$47,666 calculated based on the present value of the remaining minimum lease payments as of the adoption date. Topic 842 did not have a material impact to the Company's consolidated statement of operations (see Note 8).

In June 2016, the FASB issued ASU 2016-13, *Financial Instruments — Credit Losses (Topic 326): Measurement of Credit Losses on Financial Instruments*. Current guidance requires the allowance for doubtful accounts to be estimated based on an incurred loss model, which considers past and current conditions. Topic 326 requires companies to use an expected loss model that also considers reasonable and supportable forecasts of future conditions. Additionally, Topic 326 requires the allowance for doubtful accounts balance (contra-asset) to be presented separately in the consolidated balance sheets. Topic 326 is effective for the Company for the annual period beginning after December 15, 2020, including interim periods within that annual period. The Company adopted ASU 2016-13 as of January 1, 2020 using the modified retrospective method of adoption. The adoption of the ASU did not have a material impact on the Company's consolidated results of operations and financial position.

In August 2018, the FASB issued ASU No. 2018-13, *Fair Value Measurement (Topic 820): Disclosure Framework-Changes to the Disclosure Requirements for Fair Value Measurement*. ASU 2018-13 modifies

## BENTLEY SYSTEMS, INCORPORATED AND SUBSIDIARIES

### Notes to Consolidated Financial Statements (Continued) (in thousands, except share and per share data) (unaudited)

#### Note 2: Recent Accounting Pronouncements (Continued)

certain required disclosures and establishes new requirements related to fair value measurement. Additionally, the disclosure requirement to state the reasons for transfers between Level 1 and Level 2, the policy for timing transfers between levels, and the valuation process for Level 3 measurements have been removed. ASU 2018-13 is effective for the Company for the annual period beginning after December 15, 2019, including interim periods within that annual period. The Company adopted the ASU effective January 1, 2020. The adoption of this ASU did not have a material impact on the Company's consolidated results of operations and financial position.

In December 2019, the FASB issued ASU No. 2019-12, *Income Taxes (Topic 740): Simplifying the Accounting for Income Tax*, which is intended to simplify various aspects related to accounting for income taxes. ASU 2019-12 removes certain exceptions to the general principles in Topic 740 and clarifies and amends existing guidance to improve consistent application. ASU 2019-12 is effective for the Company for the annual period beginning after December 15, 2021, including interim periods within that annual period. The Company adopted the ASU effective January 1, 2020. The adoption of this ASU did not have a material impact on the Company's consolidated results of operations and financial position.

#### Note 3: Revenue from Contracts with Customers

The Company recognizes revenue upon the transfer of promised goods or services to customers in an amount that reflects the expected consideration received in exchange for those goods or services.

##### Nature of Products and Services

The Company generates revenues from subscriptions, perpetual licenses, and professional services.

##### Subscriptions

*SELECT subscriptions* — A prepaid annual recurring subscription that accounts (which are based on distinct contractual and billing relationships with the Company, where affiliated entities of a single parent company may each have an independent account with the Company) can elect to add to a new or previously purchased perpetual license. SELECT provides accounts with benefits, including upgrades, comprehensive technical support, pooled licensing benefits, annual portfolio balancing exchange rights, learning benefits, certain Azure-based cloud collaboration services, mobility advantages, and access to other available benefits. SELECT subscription revenues are recognized as distinct performance obligations are satisfied. The performance obligations within the SELECT offering, outside of the portfolio balancing exchange right, are concurrently delivered and have the same pattern of recognition. These performance obligations are accounted for ratably over the term as a single performance obligation.

*Enterprise subscriptions* — The Company also provides Enterprise subscription offerings which provide its largest accounts with complete and unlimited global access to the Company's comprehensive portfolio of solutions. Enterprise License Subscriptions ("ELS") provide access for a prepaid fee, which is based on the account's usage of software in the preceding year, effectively a fee-certain consumption-based arrangement. ELS contain a term license component, SELECT maintenance and support, and performance consulting days. The SELECT maintenance and support benefits under ELS do not include a portfolio balancing performance obligation. Revenue is allocated to the various performance obligations based on their respective standalone selling price ("SSP"). Revenue allocated to the term license component is recognized upon delivery at the start of the subscription term while revenues for the SELECT maintenance and support and the performance consulting days are recognized as delivered over the subscription term. Billings in advance are recorded as *Deferred revenues* in the consolidated balance sheets.

E365 subscriptions ("E365"), which were introduced during the fourth quarter of 2018, provide unrestricted access to the Company's comprehensive software portfolio, similar to ELS, however, the

## BENTLEY SYSTEMS, INCORPORATED AND SUBSIDIARIES

### Notes to Consolidated Financial Statements (Continued) (in thousands, except share and per share data) (unaudited)

#### Note 3: Revenue from Contracts with Customers (Continued)

accounts are charged based upon daily usage. The daily usage fee includes a term license component, SELECT maintenance and support, and Success Plan services, which are designed to achieve business outcomes through more efficient and effective use of the Company's software. E365 revenues are recognized based upon usage incurred by the account. Usage is defined as distinct user access on a daily basis. The term of E365 subscriptions aligns with calendar quarters and revenue is recognized based on actual usage.

*Term license subscriptions* — The Company provides annual, quarterly, and monthly term licenses for its software products. Term license subscriptions contain a term license component and SELECT maintenance and support. Revenue is allocated to the various performance obligations based on their SSP. Annual term licenses ("ATL") are generally prepaid annually for named user access to specific products. Quarterly term license ("QTL") subscriptions allow accounts to pay quarterly in arrears for license usage that is beyond their prepaid subscriptions. Monthly term license ("MTL") subscriptions are identical to QTL subscriptions, except for the term of the license, and the manner in which they are monetized. MTL subscriptions require a Cloud Services Subscription ("CSS"), which is described below. For ATL, revenue allocated to the term license component is recognized upon delivery at the start of the subscription term while revenue for the SELECT maintenance and support is recognized as delivered over the subscription term. Billings in advance are recorded as *Deferred revenues* in the consolidated balance sheets. For usage-based QTL and MTL subscriptions, revenues are recognized based upon usage incurred by the account. Usage is defined as peak usage over the respective terms. The terms of QTL and MTL subscriptions align with calendar quarters and calendar months, respectively, and revenue is recognized based on actual usage.

Visas and Passports are quarterly or annual term licenses enabling users to access specific project or enterprise information and entitle certain functionality of the Company's ProjectWise and AssetWise systems. The Company's standard offerings are usage based with monetization through the Company's CSS program as described below.

CSS is a program designed to streamline the procurement, administration, and payment process. The program requires an account to estimate their annual usage for CSS eligible offerings and deposit funds in advance. Actual consumption is monitored and invoiced against the deposit on a calendar quarter basis. CSS balances not utilized for eligible products or services may roll over to future periods or are refundable. Paid and unconsumed CSS balances are recorded in *Accruals and other current liabilities* in the consolidated balance sheets. Software and services consumed under CSS are recognized pursuant to the applicable revenue recognition guidance for the respective software or service and classified as subscriptions or services based on their respective nature.

#### *Perpetual licenses*

Perpetual licenses may be sold with or without attaching a SELECT subscription. Historically, attachment and retention of the SELECT subscription has been high given the benefits of the SELECT subscription. Perpetual license revenue is recognized upon delivery of the license to the user.

#### *Services*

The Company provides professional services including training, implementation, configuration, customization, and strategic consulting services. The Company performs projects on both a time and materials and a fixed fee basis. The Company's recent and preferred contractual structures for delivering professional services include (i) delivery of the services in the form of subscription-like, packaged offerings which are annually recurring in nature, and (ii) delivery of the Company's growing portfolio of Success Plans in standard offerings which offer a level of subscription service over and above the standard technical support offered to all accounts as part of their SELECT or Enterprise agreement. Revenues are recognized as services are performed.

## BENTLEY SYSTEMS, INCORPORATED AND SUBSIDIARIES

### Notes to Consolidated Financial Statements (Continued) (in thousands, except share and per share data) (unaudited)

#### Note 3: Revenue from Contracts with Customers (Continued)

The Company primarily utilizes its direct internal sales force and also has arrangements through independent channel partners to promote and sell Bentley products and subscriptions to end-users. Channel partners are authorized to promote the sale of an authorized set of Bentley products and subscriptions within an authorized geography under a Channel Partner Agreement.

#### Significant Judgments and Estimates

The Company's contracts with customers may include promises to transfer licenses (perpetual or term-based), maintenance, and services to a user. Judgment is required to determine if the promises are separate performance obligations, and if so, the allocation of the transaction price to each performance obligation. When an arrangement includes multiple performance obligations which are concurrently delivered and have the same pattern of transfer to the customer, the Company accounts for those performance obligations as a single performance obligation. For contracts with more than one performance obligation, the transaction price is allocated among the performance obligations in an amount that depicts the relative SSP of each obligation. Judgment is required to determine the SSP for each distinct performance obligation. In instances where SSP is not directly observable, such as when the Company does not sell the product or service separately, the Company determines the SSP using information that may include market conditions and other observable inputs. The Company uses a range of amounts to estimate SSP when it sells each of the products and services separately and needs to determine whether there is a discount that should be allocated based on the relative SSP of the various products and services.

The Company's SELECT agreement provides users with perpetual licenses a right to exchange software for other eligible perpetual licenses on an annual basis upon renewal. The Company refers to this option as portfolio balancing and concluded that the portfolio balancing feature represents a material right resulting in the deferral of the associated revenue. Judgment is required to estimate the percentage of users who may elect to portfolio balance and considers inputs such as historical user elections. This feature is available once per term and must be exercised prior to the respective renewal term. The Company recognizes the associated revenue upon election or when the portfolio balancing right expires. This right is included in the initial and subsequent renewal terms and the Company reestablishes the revenue deferral for the material right upon the beginning of the renewal term. As of June 30, 2020, the Company has deferred \$17,522 related to portfolio balancing exchange rights which is included in *Deferred revenues* in the consolidated balance sheet.

#### Contract Assets and Contract Liabilities

	December 31, 2019	June 30, 2020
Contract assets	\$ 644	\$ 344
Deferred revenues	213,145	186,456

As of June 30, 2020, the Company's contract assets relate to performance obligations completed in advance of the right to invoice and are included in *Prepaid and other current assets*. Contract assets were not impaired as of June 30, 2020.

Deferred revenues consist of billings made or payments received in advance of revenue recognition from subscriptions and professional services. The timing of revenue recognition may differ from the timing of billings to users.

During the six months ended June 30, 2020, \$144,391 of revenue that was included in the December 31, 2019 deferred revenue balance was recognized. There were additional deferrals of \$118,767, which were primarily related to new billings.

## BENTLEY SYSTEMS, INCORPORATED AND SUBSIDIARIES

Notes to Consolidated Financial Statements (Continued)  
(in thousands, except share and per share data) (unaudited)

## Note 3: Revenue from Contracts with Customers (Continued)

## Remaining Performance Obligations

The Company's contracts with customers include amounts allocated to performance obligations that will be satisfied at a later date. As of June 30, 2020, amounts allocated to these remaining performance obligations are \$186,456, of which the Company expects to recognize 96.6% over the next 12 months with the remaining amount thereafter.

## Disaggregation of Revenues

The following table details revenues:

	<u>Six Months Ended June 30,</u>	
	<u>2019</u>	<u>2020</u>
Revenues:		
Subscriptions:		
SELECT subscriptions	\$131,114	\$132,339
Enterprise license subscriptions	87,639	109,290
Term license subscriptions	71,394	86,208
Subscriptions	290,147	327,837
Perpetual licenses:		
Perpetual licenses	24,468	23,193
Subscriptions and licenses	314,615	351,030
Services:		
Professional services (recurring)	10,444	7,316
Professional services (other)	22,085	20,634
Services	32,529	27,950
Total revenues	<u>\$347,144</u>	<u>\$378,980</u>

The Company recognizes perpetual licenses and the term license component of subscriptions as revenue when either the licenses are delivered or at the start of the subscription term. For the six months ended June 30, 2019 and 2020, the Company recognized \$143,742 and \$160,270 of license related revenues, respectively, of which \$119,274 and \$137,077, respectively, was attributable to the term license component of the Company's subscription based commercial offerings recorded in Subscriptions.

The Company derived 7% and 8% of its total revenues through channel partners for the six months ended June 30, 2019 and 2020, respectively.

Revenue to external customers is attributed to individual countries based upon the location of the customer.

	<u>Six Months Ended June 30,</u>	
	<u>2019</u>	<u>2020</u>
Revenues:		
Americas <sup>(1)</sup>	\$167,440	\$185,838
Europe, the Middle East, and Africa <sup>(2)</sup>	115,811	121,578
Asia Pacific	63,893	71,564
Total Revenues	<u>\$347,144</u>	<u>\$378,980</u>

## BENTLEY SYSTEMS, INCORPORATED AND SUBSIDIARIES

Notes to Consolidated Financial Statements (Continued)  
(in thousands, except share and per share data) (unaudited)

## Note 3: Revenue from Contracts with Customers (Continued)

- (1) Americas includes the United States, Canada, and Latin America (including the Caribbean). Revenue attributable to the United States totaled \$142,795 and \$159,201 for the six months ended June 30, 2019 and 2020, respectively.
- (2) Revenue attributable to the United Kingdom totaled \$27,297 and \$27,885 for the six months ended June 30, 2019 and 2020, respectively.

## Note 4: Acquisitions

During the year ended December 31, 2019 and the six months ended June 30, 2020, the Company completed a number of acquisitions, none of which were material, individually or in the aggregate, to the Company's consolidated statements of operations and financial position. The aggregate details of the Company's acquisition activity are as follows:

	Acquisitions Completed in	
	Year Ended December 31, 2019	Six Months Ended June 30, 2020
Number of acquisitions	4	3
Cash paid at closing <sup>(1)</sup>	\$36,577	\$69,659
Cash acquired	(2,523)	(2,064)
Net cash paid	<u>\$34,054</u>	<u>\$67,595</u>

- (1) Of the cash paid at closing during the six months ended June 30, 2020, \$3,413 was deposited into an escrow account to secure any potential indemnification and other obligations of the seller.

As of December 31, 2019, the fair value of the contingent consideration related to acquisitions totaled \$6,599, of which \$5,100 is included in *Accruals and other current liabilities* and \$1,499 is included in *Other liabilities* in the consolidated balance sheet.

As of June 30, 2020, the fair value of the contingent consideration related to acquisitions totaled \$5,761, of which \$4,223 is included in *Accruals and other current liabilities* and \$1,538 is included in *Other liabilities* in the consolidated balance sheet.

As of December 31, 2019 and June 30, 2020, respectively, total current deferred payment obligations including contingent consideration for all acquisitions were \$5,999 and \$4,954, respectively and are included in *Accruals and other current liabilities* in the consolidated balance sheet.

As of December 31, 2019 and June 30, 2020, respectively, total long-term deferred payment obligations including contingent consideration for all acquisitions were \$1,499 and \$1,538 and are included in *Other liabilities* in the consolidated balance sheets.

As of June 30, 2020, there is \$891 due to the Company related to subsequent net working capital adjustments from a 2020 acquisition, which is included in *Accounts receivable* in the consolidated balance sheet.

The operating results of the acquired businesses are included in the Company's consolidated financial statements from the closing date of each respective acquisition. The purchase price for each acquisition has been allocated to the net tangible and intangible assets and liabilities based on their estimated fair values at the acquisition date. Independent valuations are obtained to support purchase price allocations when deemed appropriate.



## BENTLEY SYSTEMS, INCORPORATED AND SUBSIDIARIES

Notes to Consolidated Financial Statements (Continued)  
(in thousands, except share and per share data) (unaudited)

## Note 4: Acquisitions (Continued)

In connection with the purchase price allocations related to the Company's acquisitions, the Company has estimated the fair values of the support obligations assumed relative to acquired deferred revenue. The estimated fair values of the support obligations assumed were determined using a cost-build-up approach. The cost-build-up approach determines fair value by estimating the costs related to fulfilling the obligations plus a normal profit margin. For accounting purposes, the sum of the costs and operating profit approximates the amount that the Company would be required to pay a third party to assume the support obligations. These fair value adjustments reduce the revenues recognized over the remaining support contract term of the Company's acquired contracts. During the year ended December 31, 2019 and the six months ended June 30, 2020, the fair value adjustments to reduce revenue were \$553 and \$195, respectively.

The purchase accounting for two acquisitions completed during the year ended December 31, 2019 and three acquisitions completed during the six months ended June 30, 2020, are not yet completed. Identifiable assets acquired and liabilities assumed were provisionally recorded at their estimated fair values on the acquisition date. The initial accounting for these business combinations is not complete because the evaluation necessary to assess the fair values of certain net assets acquired is still in process. The provisional amounts are subject to revision until the evaluations are completed to the extent that additional information is obtained about the facts and circumstances that existed as of the acquisition date. The allocation of the purchase price may be modified from the date of the acquisition as more information is obtained about the fair values of assets acquired and liabilities assumed, however such measurement period cannot exceed one year.

Acquisition and integration costs are expensed as incurred. During the six months ended June 30, 2019 and 2020, the Company incurred acquisition and integration costs of \$251 and \$1,078, respectively, which include costs related to legal, accounting, valuation, general administrative, and other consulting fees. Such costs are recorded in *General and administrative* in the Company's consolidated statements of operations.

The following summarizes the fair values of the assets acquired and liabilities assumed as well as the weighted average useful lives assigned to acquired intangible assets at the respective date of each acquisition (including contingent consideration):

	Acquisitions Completed in	
	Year Ended December 31, 2019	Six Months Ended June 30, 2020
Consideration:		
Cash paid at closing	\$36,577	\$69,659
Contingent consideration	4,498	1,706
Deferred payment obligations to (from) sellers	—	(1,069)
<b>Total consideration</b>	<b>\$41,075</b>	<b>\$70,296</b>
Assets acquired and liabilities assumed:		
Cash	\$ 2,523	\$ 2,064
Prepaid and other current assets	1,782	5,697
Right-of-use assets	—	1,668
Property and equipment	411	172
Other assets	84	—
Customer relationship asset (weighted average useful life of 7 years)	6,534	8,941
Software and technology (weighted average useful life of 3 years)	2,423	1,751
Non-compete agreement (useful life of 5 years)	150	200

## BENTLEY SYSTEMS, INCORPORATED AND SUBSIDIARIES

Notes to Consolidated Financial Statements (Continued)  
(in thousands, except share and per share data) (unaudited)

## Note 4: Acquisitions (Continued)

	Acquisitions Completed in	
	Year Ended December 31, 2019	Six Months Ended June 30, 2020
Trademarks (weighted average useful life of 5 and 9 years, respectively)	1,431	3,010
Total identifiable assets acquired excluding goodwill	15,338	23,503
Deferred revenues	(2,897)	(4,274)
Other current liabilities	(3,538)	(2,504)
Operating lease liabilities	—	(1,668)
Non-current liabilities	—	(41)
Deferred income taxes	(1,869)	(978)
Total liabilities assumed	(8,304)	(9,465)
Net identifiable assets acquired excluding goodwill	7,034	14,038
Goodwill	34,041	56,258
Net assets acquired	<u>\$41,075</u>	<u>\$70,296</u>

The fair values of the working capital, other assets (liabilities), and property and equipment approximated their respective carrying values as of the acquisition date.

As discussed above, the fair values of deferred revenues were determined using the cost-build-up approach.

The fair values of the intangible assets were primarily determined using the income approach. When applying the income approach, indications of fair values were developed by discounting future net cash flows to their present values at market-based rates of return. The cash flows were based on estimates used to price the acquisitions and the discount rates applied were benchmarked with reference to the implied rate of return from the Company's pricing model and the weighted average cost of capital.

Goodwill recorded in connection with the acquisitions was attributable to synergies expected to arise from cost saving opportunities as well as future expected cash flows. Of the goodwill recorded as of June 30, 2020, \$23,267 is expected to be deductible for tax purposes.

## Note 5: Property and Equipment, Net

Property and equipment, net consist of the following at December 31, 2019 and June 30, 2020:

	December 31, 2019	June 30, 2020
Land	\$ 2,811	\$ 2,811
Building and improvements	31,619	32,435
Computer equipment and software	47,472	50,637
Furniture, fixtures, and equipment	12,593	12,730
Aircraft	3,910	4,075
Other	79	79
Property and equipment, at cost	98,484	102,767
Less accumulated depreciation	(68,852)	(72,464)
Total property and equipment, net	<u>\$ 29,632</u>	<u>\$ 30,303</u>

## BENTLEY SYSTEMS, INCORPORATED AND SUBSIDIARIES

Notes to Consolidated Financial Statements (Continued)  
(in thousands, except share and per share data) (unaudited)**Note 5: Property and Equipment, Net (Continued)**

Depreciation expense for the six months ended June 30, 2019 and 2020 was \$4,799 and \$4,926, respectively.

**Note 6: Goodwill and Other Intangible Assets**

The changes in the carrying amount of goodwill for the six months ended June 30, 2020 are as follows:

Balance, December 31, 2019	\$480,065
Acquisitions	56,258
Foreign currency translation adjustments	(6,712)
Other adjustments	148
Balance, June 30, 2020	<u>\$529,759</u>

Details of intangible assets other than goodwill as of December 31, 2019 and June 30, 2020 are as follows:

	Estimated Useful Life	As of December 31, 2019			As of June 30, 2020		
		Gross Carrying Amount	Accumulated Amortization	Net Book Value	Gross Carrying Amount	Accumulated Amortization	Net Book Value
<b>Intangible assets subject to amortization</b>							
Software and technology	3 years	\$ 66,063	\$ (58,866)	\$ 7,197	\$ 67,222	\$ (60,648)	\$ 6,574
Customer relationships	3 – 10 years	88,904	(59,744)	29,160	96,801	(64,451)	32,350
Trademarks	3 – 10 years	22,278	(12,461)	9,817	25,084	(14,317)	10,767
Non-compete agreements	5 years	150	(11)	139	350	(33)	317
<b>Total intangible assets</b>		<u>\$177,395</u>	<u>\$(131,082)</u>	<u>\$46,313</u>	<u>\$189,457</u>	<u>\$(139,449)</u>	<u>\$50,008</u>

The aggregate amortization expense for purchased intangible assets with finite lives recorded for the six months ended June 30, 2019 and 2020 was reflected in our consolidated statements of operations as follows:

	Six Months Ended June 30,	
	2019	2020
Cost of subscriptions and licenses	\$1,846	\$2,161
Amortization of purchased intangibles	6,851	7,115
Total amortization expense	<u>\$8,697</u>	<u>\$9,276</u>

**Note 7: Investment in Joint Venture**

In September 2019, the Company and Topcon Positioning Systems, Inc. formed Digital Construction Works, Inc. (“DCW”), a joint venture which operates as a digital integrator of software and cloud services for the construction industry. DCW’s focus is to transform the construction industry from its legacy document-centric paradigm by simplifying and enabling digital automated workflows and processes, technology integration, and digital twinning services for infrastructure.

The Company and Topcon each have a 50% ownership in DCW. The Company applies the equity method of accounting for its investment in DCW. Under the equity method, the Company recorded its

**BENTLEY SYSTEMS, INCORPORATED AND SUBSIDIARIES**

**Notes to Consolidated Financial Statements (Continued)**  
**(in thousands, except share and per share data) (unaudited)**

**Note 7: Investment in Joint Venture (Continued)**

initial investment in the joint venture at cost and subsequently adjusts that investment by the Company's proportional share of income or losses in DCW. As of December 31, 2019 and June 30, 2020, the aggregate carrying amount of the Company's investment in the joint venture was \$1,725 and \$859, respectively. The Company tests this investment for impairment whenever circumstances indicate that the carrying value of the investment may not be recoverable.

Pursuant to ASC 850-10-20, *Related Party Disclosures*, the Company has determined that DCW is a related party. For the six months ended June 30, 2020, transactions between the Company and DCW were immaterial to the Company's consolidated financial statements.

**Note 8: Leases**

The Company's operating leases consist of office facilities, office equipment, and cars, and the Company's finance leases consist of office equipment. Finance leases are not material for the periods presented. The Company's leases have remaining terms of less than one year to 7.3 years, some of which include one or more options to renew, with renewal terms of up to six years and some of which include options to terminate the leases within the next four years.

For contracts with lease and non-lease components, the Company has elected not to allocate the contract consideration, and account for the lease and non-lease components as a single lease component. Payments under the Company's lease arrangements are primarily fixed, however, certain lease agreements contain variable payments, which are expensed as incurred and not included in the operating lease assets and liabilities. Variable lease cost may include common area maintenance, property taxes, utilities, and fluctuations in rent due to a change in an index or rate. The Company has elected not to recognize a right-of-use asset or lease liability for short-term leases (leases with a term of twelve months or less). Short-term leases are recognized in the consolidated statement of operations on a straight-line basis over the lease term. Short-term lease expense was not material for the periods presented.

The components of operating lease cost reflected in the consolidated statement of operations for the six months ended June 30, 2020 were as follows:

	<b>Six Months Ended June 30, 2020</b>
Operating lease cost <sup>(1)</sup>	\$ 8,859
Variable lease cost	1,882
Short-term lease cost	7
Total operating lease cost	<u>\$10,748</u>

(1) Operating lease cost includes rent cost related to operating leases for office facilities of \$8,471 for the six months ended June 30, 2020.

## BENTLEY SYSTEMS, INCORPORATED AND SUBSIDIARIES

Notes to Consolidated Financial Statements (Continued)  
(in thousands, except share and per share data) (unaudited)

## Note 8: Leases (Continued)

Other information related to leases for the six months ended June 30, 2020 was as follows:

	Six Months Ended June 30, 2020
Cash paid for amounts included in the measurement of lease liabilities:	
Operating cash flows from operating leases	\$ 9,003
Right-of-use assets obtained in exchange for new operating lease liabilities	\$13,118
Weighted-average remaining lease term — operating leases (in years)	3.83
Weighted-average discount rate — operating leases	2.26%

Maturities of operating lease liabilities as of June 30, 2020 are as follows:

	As of June 30, 2020
Remainder of 2020	\$ 9,094
2021	15,875
2022	12,215
2023	7,886
2024	4,115
Thereafter	4,523
Total future lease payments	53,708
Less: imputed interest	(3,567)
Total operating lease liabilities	<u>\$50,141</u>

As of June 30, 2020, the Company had additional operating lease minimum lease payments of \$213 for executed leases that have not yet commenced, primarily for office locations.

Total financing lease liabilities as of June 30, 2020 were \$354. Supplemental balance sheet information related to financing leases as of June 30, 2020 are as follows:

	As of June 30, 2020
Property and equipment	\$ 520
Accumulated depreciation	(108)
Property and equipment, net	<u>\$ 412</u>
Accruals and other current liabilities	\$ 176
Other liabilities	178
Total financing lease liabilities	<u>\$ 354</u>

## BENTLEY SYSTEMS, INCORPORATED AND SUBSIDIARIES

Notes to Consolidated Financial Statements (Continued)  
(in thousands, except share and per share data) (unaudited)**Note 8: Leases (Continued)**

As of December 31, 2019, under the prior lease standard (Topic 840), future minimum lease payments under noncancellable operating leases are as follows:

	As of December 31, 2019
2020	\$15,886
2021	13,186
2022	10,385
2023	6,572
2024	3,216
Thereafter	2,771
Total minimum lease payments	<u>\$52,016</u>

**Note 9: Accruals and Other Current Liabilities**

Accruals and other current liabilities consist of the following:

	December 31, 2019	June 30, 2020
Cloud Services Subscription deposits	\$ 54,688	\$ 84,180
Accrued benefits	33,184	26,763
Accrued compensation	31,537	21,353
Due to customers	8,945	10,526
Accrued acquisition stay bonuses	4,143	5,058
Contingent consideration from acquisitions	5,100	4,223
Sales taxes payable	5,287	4,110
Accrued professional fees	4,382	2,591
Accrued hosting costs	2,215	2,121
Accrued facility costs	2,168	1,908
Accrued severance and realignment costs	1,688	825
Non-contingent consideration from acquisitions	900	731
Accrued rent	1,909	—
Other accrued and current liabilities	11,371	10,500
Total accruals and other current liabilities	<u>\$167,517</u>	<u>\$174,889</u>

**Note 10: Long-Term Debt**

Long-term debt consists of the following at December 31, 2019 and June 30, 2020:

	December 31, 2019	June 30, 2020
Bank credit facility:		
Senior secured revolver	\$233,750	\$207,000
Total long-term debt	<u>\$233,750</u>	<u>\$207,000</u>

**BENTLEY SYSTEMS, INCORPORATED AND SUBSIDIARIES**

**Notes to Consolidated Financial Statements (Continued)**  
**(in thousands, except share and per share data) (unaudited)**

**Note 10: Long-Term Debt (Continued)**

**Bank Credit Facility**—On December 19, 2017, the Company entered into an amended and restated credit agreement (the “Credit Facility”), which matures on December 18, 2022. Upon entry into the Credit Facility, the Company obtained a \$500,000 senior secured revolving facility and refinanced all indebtedness outstanding under its prior facility.

In addition to the revolving line of credit, the Credit Facility also provides up to \$50,000 of letters of credit and other incremental borrowings subject to availability, including a \$50,000 multi-currency swing-line sub-facility and a \$100,000 incremental “accordion” sub-facility. The Company had \$546 and \$150 of letters of credit and surety bonds outstanding as of December 31, 2019 and June 30, 2020, respectively. As of December 31, 2019 and June 30, 2020, the Company had \$265,704 and \$292,850 available under the Credit Facility.

Under the Credit Facility, the Company may make either Euro currency or non-Euro currency interest rate elections. Interest on the Euro currency borrowings is at the one-month London Interbank Offered Rate (“LIBOR”) plus a spread ranging from 100 basis points (“bps”) to 225 bps as determined by the Company’s net leverage ratio. Under the non-Euro currency elections, Credit Facility borrowings bear a base interest rate of the greater of (i) the prime rate, (ii) the overnight bank funding effective rate plus 50 bps, or (iii) LIBOR plus 100 bps, plus a spread ranging from 0 bps to 125 bps as determined by the Company’s leverage ratio. In addition, a commitment fee for the unused Credit Facility ranges from 15 bps to 30 bps as determined by the Company’s net leverage ratio.

Borrowings under the Credit Facility are guaranteed by all of the Company’s first tier domestic subsidiaries and are secured by a first priority security interest in substantially all of the Company’s and the guarantors’ U.S. assets and 65% of the stock of their directly owned foreign subsidiaries. The Credit Facility contains both affirmative and negative covenants, including maximum leverage ratios. At December 31, 2019 and June 30, 2020, the Company was in compliance with all covenants in its debt agreements.

Interest rate risk associated with the Credit Facility is managed through an interest rate swap which the Company executed on March 31, 2020. The swap has an effective date of April 2, 2020 and a termination date of April 2, 2030. Under the terms of the swap, the Company fixed its LIBOR borrowing rate at 0.73% on a notional amount of \$200,000. The interest rate swap is not designated as a hedging instrument for accounting purposes. The Company accounts for the swap as either an asset or a liability on the balance sheet and carries the derivative at fair value. Gains and losses from the change in fair value are recognized in *Other income (expense), net* in the consolidated statements of operations. At June 30, 2020, the fair value of the swap was \$4,174.

For the six months ended June 30, 2019 and 2020, the weighted average interest rate under the Credit Facility was 3.73% and 2.18%, respectively. There was no accrued interest or fees as of December 31, 2019. As of June 30, 2020, accrued interest and fees was \$33. Interest expense was \$4,600 and \$2,544 for the six months ended June 30, 2019 and 2020, respectively.

In addition, interest expense includes amortization of deferred financing costs of \$277 for the six months ended June 30, 2019 and 2020.

**Other**—Interest expense related to other obligations was \$144 and \$25 for the six months ended June 30, 2019 and 2020, respectively.

**Note 11: Executive Bonus Plan**

The Company has an incentive compensation program under which up to 20% of the Company’s adjusted operating profits, as defined in the plan agreement and before deductions for such plan payments,

**BENTLEY SYSTEMS, INCORPORATED AND SUBSIDIARIES**

**Notes to Consolidated Financial Statements (Continued)**  
**(in thousands, except share and per share data) (unaudited)**

**Note 11: Executive Bonus Plan (Continued)**

may be paid to plan participants in the form of cash bonuses, subject to approval by the Company's board of directors and certain limitations imposed by the Company's Credit Facility. The plan permits the deduction of certain holdback amounts from the plan's pool, from which amounts can then be allocated to fund items including equity and/or cash incentive compensation for non-plan participants and participant charitable contributions. During the six months ended June 30, 2019 and 2020, the incentive compensation, including cash payments and deferred compensation to plan participants, recognized under this plan (net of all applicable holdbacks) was \$13,639 and \$16,564, respectively.

**Note 12: Retirement Plans**

The Company maintains a qualified 401(k) profit sharing plan (the Plan) for the benefit of substantially all U.S.-based full-time colleagues. The Company may make discretionary profit-sharing contributions to the Plan up to a maximum of 5% of "qualified cash compensation" for each eligible participating colleague. Non-discretionary (matching) 401(k) contributions to the Plan, for full-time U.S. colleagues, were \$1,843 and \$1,950, for the six months ended June 30, 2019 and 2020, respectively. The Company also maintains various retirement benefit plans (primarily defined contribution plans) for colleagues of its international subsidiaries. Contributions to these plans were \$4,075 and \$3,764, for the six months ended June 30, 2019 and 2020, respectively.

The Company also has a nonqualified deferred compensation plan (the "DCP"), under which certain officers and key colleagues may elect to defer the receipt of all or a portion of their bonus compensation. In addition, the Company may make discretionary awards under the DCP on behalf of the participants. Elective participant deferrals and discretionary Company awards are required to be in the form of phantom shares of the Company's Class B Non-Voting Common Stock ("Class B Common Stock"), which are valued for tax and accounting purposes in the same manner as actual shares of Class B Common Stock. All DCP distributions to current colleague participants are made in the form of shares of Class B Common Stock. The Company's discretionary awards made prior to January 1, 2016 vest 20% on the date of grant and 20% on each of the four subsequent anniversary dates. The Company's discretionary awards made on or after January 1, 2016 are 100% vested at the time of grant. No discretionary contributions were made to the DCP during the six months ended June 30, 2019 and 2020.

Amounts in the DCP attributable to certain non-colleague participants are settled in cash and are classified as liabilities which are marked to market at the end of each reporting period. The total liability related to the DCP for non-colleague participants was \$2,544 and \$2,250 as of December 31, 2019 and June 30, 2020, respectively.

The table below shows compensation (income) expense related to the DCP recorded during the six months ended June 30, 2019 and 2020, respectively:

	Six Months Ended June 30,	
	2019	2020
DCP related compensation (income) expense	\$295	\$(165)

**Note 13: Common Stock**

**Authorized Common Shares**— The Company amended and restated its Certificate of Incorporation on April 20, 2018 to authorize 320,000,000 shares of Class A Voting Common Stock ("Class A Common Stock") and 600,000,000 shares of Class B Common Stock. As of December 31, 2019 and June 30, 2020, outstanding shares of Class A Common Stock totaled 11,601,757 and outstanding shares of Class B Common Stock totaled 243,241,192 and 247,607,598, respectively.



**BENTLEY SYSTEMS, INCORPORATED AND SUBSIDIARIES**

**Notes to Consolidated Financial Statements (Continued)**  
**(in thousands, except share and per share data) (unaudited)**

**Note 13: Common Stock (Continued)**

***Sales, Repurchases, and Issuances of Company Capital Stock***

In September 2016, the Company entered into a Class B Common Stock Purchase Agreement with a strategic investor (the “Common Stock Purchase Agreement”), pursuant to which the investor could acquire in a series of transactions up to \$200,000 of the Company’s Class B Common Stock at the then prevailing fair market value, either directly from selling stockholders, in which case the Company would act as pass through agent, or by funding the Company’s repurchase and subsequent sale to the investor of shares acquired by the Company from existing Company stockholders.

The Common Stock Purchase Agreement grants to the strategic investor certain informational and protective rights, including, for so long as the Company remains party to a long-term strategic collaboration agreement with the investor, a pre-initial public offering (“IPO”) right of first refusal on any sale of the Company and a post-IPO right to participate in any sale process the Company may undertake.

On April 23, 2018, the Company entered into an amendment to the Common Stock Purchase Agreement, which (i) increased the maximum purchase amount from \$200,000 to \$250,000 thereunder, (ii) extended the expiration of the agreement from 2026 to 2030, and (iii) granted the Company the right to retain a portion of the shares that would otherwise be sold to the investor.

During the six months ended June 30, 2019, the investor purchased 791,873 shares under the Common Stock Purchase Agreement, with 622,873 of such shares having been repurchased by the Company and re-sold to the investor for consideration of \$4,510 and 169,000 shares acquired directly by the investor for consideration of \$1,224.

During the six months ended June 30, 2020, the investor purchased 4,574,567 shares under the Common Stock Purchase Agreement, with 3,769,346 of such shares having been repurchased by the Company and re-sold to the investor for consideration of \$58,349 and 805,053 shares acquired directly by the investor for consideration of \$12,462.

During the six months ended June 30, 2019, the Company issued net 2,657,027 shares of Class B Common Stock to colleagues who exercised their stock options. Of the total options exercised for 3,805,781 shares, 916,965 shares were issued for cash totaling \$2,192, and the remaining options for 2,888,816 shares were exercised on a cashless basis, and accordingly, 1,148,754 shares were sold back to the Company to pay for the cost of the options as well as applicable income tax withholdings of \$2,161. During the six months ended June 30, 2019, the Company paid \$3,149 for 401,352 shares sold back to the Company upon exercise of the Put and Call provisions under the amended option plan (see Note 15).

During the six months ended June 30, 2020, the Company issued net 2,184,628 shares of Class B Common Stock to colleagues who exercised their stock options. Of the total options exercised for 3,410,554 shares, 566,362 shares were issued for cash totaling \$2,237, and the remaining options for 2,844,192 shares were exercised on a cashless basis, and accordingly, 1,225,926 shares were sold back to the Company to pay for the cost of the options as well as applicable income tax withholdings of \$3,064. During the six months ended June 30, 2020, the Company paid \$1,454 for 128,176 shares sold back to the Company upon exercise of the Put and Call provisions under the amended option plan (see Note 15).

During the six months ended June 30, 2019 and 2020, the Company issued 2,230,430 and 2,959,731, respectively, of shares of Class B Common Stock to DCP participants for their distribution. The distribution in shares for the six months ended June 30, 2019 totaled 2,907,630 of which 677,200 shares were sold back to the Company to pay for the cost of applicable income tax withholding of \$4,953. The distribution in shares for the six months ended June 30, 2020 totaled 3,137,961 shares of which 178,230 shares were sold back to the Company in the same period to pay for applicable income tax withholdings of \$1,830.

## BENTLEY SYSTEMS, INCORPORATED AND SUBSIDIARIES

Notes to Consolidated Financial Statements (Continued)  
(in thousands, except share and per share data) (unaudited)

## Note 13: Common Stock (Continued)

During the six months ended June 30, 2019 and 2020, the Company did not award Class B Common Stock in conjunction with profit sharing plan contributions. During the six months ended June 30, 2019 and 2020, the Company repurchased 160,963 and 385,568 shares from its profit sharing plan for \$1,213 and \$4,428, respectively.

**Selected Terms of Class B Common Stock**—Pursuant to the terms of the Company’s amended and restated Certificate of Incorporation in effect for the periods reported, each share of Class B Common Stock has the same rights and privileges as each share of Class A Common Stock, except that the holders of outstanding shares of Class B Common Stock do not have any right to vote on, or consent with respect to, any matters to be voted on or consented to by the stockholders of the Company except as required by law, and the shares of Class B Common Stock are not included in determining the number of shares voting or entitled to vote on any such matters. Each outstanding share of Class B Common Stock may be converted into one share of Class A Common Stock upon the determination of the Company’s board of directors. Additionally, absent a conversion by the board of directors, upon an IPO by the Company, each outstanding share of Class B Common Stock may be automatically converted into the class of common stock being offered.

**Dividends**—The Company declared cash dividends during the periods presented as follows:

	Dividend Per Share	Amount
2019:		
Second quarter	\$0.025	\$ 6,375
First quarter	0.025	6,268
Total	<u>\$0.050</u>	<u>\$12,643</u>
2020:		
Second quarter	\$0.030	\$ 7,771
First quarter	0.030	7,666
Total	<u>\$0.060</u>	<u>\$15,437</u>

## Note 14: Accumulated Other Comprehensive Loss

Accumulated other comprehensive loss consists of the following:

	Foreign Currency Translation	Actuarial (Loss) Gain on Retirement Plan	Total
Balance, December 31, 2018	\$(28,867)	\$(547)	\$(29,414)
Other comprehensive income (loss), before taxes	2,406	16	2,422
Tax expense	—	(6)	(6)
Other comprehensive income (loss), net of taxes	<u>2,406</u>	<u>10</u>	<u>2,416</u>
Balance, June 30, 2019	<u>\$(26,461)</u>	<u>\$(537)</u>	<u>\$(26,998)</u>

## BENTLEY SYSTEMS, INCORPORATED AND SUBSIDIARIES

Notes to Consolidated Financial Statements (Continued)  
(in thousands, except share and per share data) (unaudited)

## Note 14: Accumulated Other Comprehensive Loss (Continued)

	Foreign Currency Translation	Actuarial (Loss) Gain on Retirement Plan	Total
Balance, December 31, 2019	\$(22,908)	\$(1,019)	\$(23,927)
Other comprehensive income (loss), before taxes	(4,503)	41	(4,462)
Tax expense	—	(15)	(15)
Other comprehensive income (loss), net of taxes	(4,503)	26	(4,477)
Balance, June 30, 2020	<u>\$(27,411)</u>	<u>\$( 993)</u>	<u>\$(28,404)</u>

## Note 15: Equity Awards and Instruments

The Company has equity awards outstanding under its Amended and Restated 2015 Equity Incentive Plan (the “Equity Incentive Plan”) which provides for the granting of awards in the form of stock options, stock appreciation rights, dividend equivalent rights, restricted stock, restricted stock units, and stock grants. The Equity Incentive Plan has 50,000,000 shares of Class B Common Stock reserved for issuance and terminates in November 2024.

The following is a summary of activity under the stockholder-approved plan.

**Stock Options**—Stock options generally vest ratably on each of the first four anniversaries of the grant date. Stock options granted under this plan include Put and Call provisions that allow colleagues who have exercised an option to sell all or part of their shares acquired upon such exercise to the Company at the fair market value at the time of the sale. The exercise period for the Put right begins on the second day after the six-month anniversary of the date the option was exercised and ends after an additional 30 days. The Call right provision allows the Company to purchase all or a part of the shares acquired by a colleague upon exercise of an option, at the fair market value at the time of such purchase. The Company may exercise the Call right at any time within seven months of the later of i) the optionee’s termination of service with the Company, or ii) the optionee’s (or his or her beneficiary’s) exercise of such option after a termination of service.

The Company granted options for a total of 4,816,000 shares on March 22, 2019 and 10,000 shares on May 15, 2019. The fair value of the awards was estimated on the date of grant using the Black-Scholes option pricing model. The grant date fair value of each option to acquire a share of Class B Common Stock was \$1.66 and \$1.65, respectively.

The Company granted options for a total of 10,000 shares on March 12, 2020. The fair value of the awards was estimated on the date of grant using the Black-Scholes option pricing model. The grant date fair value of each option to acquire a share of Class B Common Stock was \$2.49.

**Stock Grants**—Under the Equity Incentive Plan, the Company may grant unrestricted, fully vested shares of Class B Common Stock to eligible colleagues. Any such shares awarded have Put and Call rights similar to those described above with respect to stock options.

The Company did not grant fully vested shares of Class B Common Stock during the six months ended June 30, 2019. The Company granted 17,411 fully vested shares of Class B Common Stock during the six months ended June 30, 2020.

**Restricted Stock**—Under the Equity Incentive Plan, the Company may grant both time and performance-based shares of restricted Class B Common Stock to eligible colleagues.

For the six months ended June 30, 2019, the Company granted 493,840 shares of restricted stock, all of which were subject to performance-based vesting as determined by the achievement of business growth

## BENTLEY SYSTEMS, INCORPORATED AND SUBSIDIARIES

Notes to Consolidated Financial Statements (Continued)  
(in thousands, except share and per share data) (unaudited)

## Note 15: Equity Awards and Instruments (Continued)

targets which included growth in annual recurring revenues as well as actual bookings for perpetual licenses and non-recurring services. Annual performance targets were seasonalized and targets were set for quarterly and annual performance periods ending on December 31, 2019. These restricted shares carried dividend, but not voting rights. During the six months ended June 30, 2019, the performance conditions to vesting were satisfied in respect of 111,224 of these shares, of which 18,763 shares were sold back to the Company to settle applicable income tax withholdings of \$136.

For the six months ended June 30, 2020, the Company granted 12,454 shares of restricted stock, which are subject to a quarterly time-based vesting schedule ending March 31, 2021. No performance shares were granted during the six months ended June 30, 2020. Of the performance shares that vested in 2019, 8,774 shares were sold back to the Company to settle applicable income tax withholdings of \$95, with the remaining shares delivered to participants in the six months ended June 30, 2020. Of the performance shares granted in 2019, 292,131 did not vest and were canceled during the six months ended June 30, 2020.

**Restricted Stock Units** — Under the Equity Incentive Plan, the Company may grant both time and performance based restricted stock units (“RSUs”) to eligible colleagues, which entitle the grantee to receive a specific number of shares of our Class B Common Stock upon vesting. These shares also have dividend equivalent rights.

No restricted stock units were granted during the six months ended June 30, 2019 or 2020. In 2016, the Company granted RSUs subject to performance-based vesting as determined by the achievement of business growth targets which included growth in annual recurring revenues as well as actual bookings for perpetual licenses and non-recurring services. Annual performance targets were seasonalized and targets were set for quarterly and annual performance periods ending on December 31, 2016. Certain colleagues elected to defer delivery of such shares upon vesting. During the six months ended June 30, 2020, 9,830 shares were delivered to colleagues and 3,168 shares were sold back to the Company to settle income tax withholdings of \$26. As of December 31, 2019 and June 30, 2020, 54,770 and 45,151, respectively, of these RSUs remained outstanding.

The following is a summary of option activity under the Company’s Equity Incentive Plan:

	Options Outstanding	Exercise Price Per Share	
		Range	Weighted Average
<b>Balance, December 31, 2019</b>	18,691,667	\$3.50 – \$7.24	\$ 5.97
Option activity:			
Granted	10,000	10.84	10.84
Exercised	(3,410,554)	3.50 – 7.24	4.43
Canceled	(191,750)	3.50 – 7.24	6.47
<b>Balance, June 30, 2020</b>	<u>15,099,363</u>	\$5.23 – \$10.84	\$ 6.31

## BENTLEY SYSTEMS, INCORPORATED AND SUBSIDIARIES

Notes to Consolidated Financial Statements (Continued)  
(in thousands, except share and per share data) (unaudited)

## Note 15: Equity Awards and Instruments (Continued)

The following is a summary of options outstanding and exercisable by exercise price under the Company's Equity Incentive Plan as of June 30, 2020:

Exercise Prices	Number of Options Outstanding	Weighted Remaining Contractual Life (in years)	Exercisable
\$5.23 – \$6.00	6,328,614	1.30	5,343,930
6.01 – 8.00	8,760,749	3.32	3,068,999
8.01 – 10.84	10,000	4.70	—
Total	<u>15,099,363</u>		<u>8,412,929</u>

For the year ended December 31, 2019 and the six months ended June 30, 2020, the Company received cash proceeds of \$3,612 and \$2,237, respectively, related to the exercise of stock options.

The following is a summary of the intrinsic value of options outstanding and exercisable under the Company's Equity Incentive Plan as of June 30, 2020:

	Number of Options	Weighted Average Exercise Price	Aggregate Intrinsic Value	Weighted Remaining Contractual Life (in years)
Options as of June 30, 2020				
Outstanding	15,099,363	\$6.31	\$138,476	2.5
Exercisable	8,412,929	\$5.90	\$80,584	1.9

**Acquisition Options**—In addition to options granted under the Company's Equity Incentive Plan, in connection with an acquisition completed in March 2018, the Company issued to certain selling shareholder entities options to acquire an aggregate of up to 900,000 shares of Class B Common Stock. The options have a five-year term, vest on the fourth anniversary of the closing of the acquisition, and an initial exercise price of \$6.805 per share. The exercise price of the options is subject to a cap and collar adjustment mechanism that automatically reduces (but not to less than \$0.01) or increases the exercise price based on the difference between the exercise price and the fair market value of the Company's Class B Common Stock on the exercise date. The fair value of the awards was estimated on the date of grant using the Black-Scholes option pricing model. The grant date fair value of each option was \$3.44. Any shares of Class B Common Stock acquired upon exercise of the options are generally entitled to the Put and Call rights summarized above under "Stock Options," and the options contain customary adjustment provisions in case of stock splits, stock dividends, or other corporate transactions. As of December 31, 2019 and June 30, 2020, all options to acquire 900,000 shares remain outstanding. As of June 30, 2020, these options are non-exercisable and have an aggregate intrinsic value of \$7,808.

Compensation expense is recognized on a straight-line basis over the vesting period during which colleagues perform related services. During the six months ended June 30, 2019 and 2020, the Company recorded \$3,220 and \$2,956, respectively, of stock-based compensation expense related to stock options, \$805 and \$37, respectively, of compensation expense related to restricted stock, and \$0 and \$219, respectively, of stock-based compensation expense related to grants of fully vested shares.

As of June 30, 2020, there was \$9,036 of unrecognized compensation cost related to unvested stock options, which is expected to be recognized over a weighted average period of approximately 2.3 years.

The total intrinsic value of stock options exercised in the six months ended June 30, 2019 and 2020 was \$19,995 and \$30,536, respectively.

**BENTLEY SYSTEMS, INCORPORATED AND SUBSIDIARIES**

**Notes to Consolidated Financial Statements (Continued)**  
**(in thousands, except share and per share data) (unaudited)**

**Note 15: Equity Awards and Instruments (Continued)**

The value of each stock option award was estimated on the date of grant using the Black-Scholes option pricing model. The determination of the fair value of share-based payment awards using an option pricing model is affected by the Company's stock price as well as assumptions regarding a number of complex and subjective variables. These variables include the Company's expected stock price volatility over the term of the awards, actual and projected colleague stock option exercise behaviors, risk-free interest rates, and expected dividends, which are estimated as follows:

*Expected volatility.* The expected stock price volatility for the Company's common stock was estimated by taking the average historic price volatility for industry peers based on daily price observations over a period equivalent to the expected term of the stock option grants. The Company intends to continue to consistently apply this process using the same or similar public companies until a sufficient amount of historical information regarding the volatility of the Company's own common stock share price becomes available.

*Expected dividend yield.* Prior to 2015, the Company had never declared or paid a cash dividend. Consequently, the Company used an expected dividend yield of zero for all option grants prior to 2015. In February 2015, the Company's board of directors established a policy to pay a quarterly dividend with the first such quarterly dividend paid in June 2015. While the Company intends to continue paying quarterly dividends, any future determination and amount per share will be subject to the discretion of the Company's board of directors and will be dependent on a number of factors, including the Company's operating results, capital requirements, restrictions under Delaware law, and overall financial conditions, as well as any other factors the Company's board of directors considers relevant.

*Expected term.* The expected term represents the period that the Company's stock-based awards are expected to be outstanding. The expected term is based on the simplified method, which represents the average period from vesting to the expiration of the award.

*Risk-free rate.* The risk-free interest rate is based on the yields of U.S. Treasury securities with maturities similar to the expected term of the options for each option group.

	<b>Year Ended December 31, 2019</b>	<b>Six Months Ended June 30, 2020</b>
Expected volatility	29.57%	31.04%
Expected dividend yield	1.38%	1.11%
Risk-free interest rate	2.48%	1.31%
Expected term (in years)	3.75	3.75
Weighted average grant date fair value of options issued	\$ 1.66	\$ 2.49

The fair value of the common stock was determined by the board of directors at each award grant date based upon a variety of factors, including the results obtained from independent third-party valuations, the Company's financial position, and historical financial performance.

The Company paid \$3,149 and \$1,454 during the six months ended June 30, 2019 and 2020, respectively, to stockholders who exercised their options and elected to sell the shares back to the Company after the mandatory six-month holding period as well as for shares acquired by the Company exercising its call rights.

**Note 16: Income Taxes**

The Company calculates its interim income tax provision in accordance with FASB ASC Topics 270, *Interim Reporting*, and 740, *Income Taxes*. At the end of each interim period, the Company makes an estimate

**BENTLEY SYSTEMS, INCORPORATED AND SUBSIDIARIES****Notes to Consolidated Financial Statements (Continued)**  
**(in thousands, except share and per share data) (unaudited)****Note 16: Income Taxes (Continued)**

of the annual United States domestic and foreign jurisdictions' expected effective tax rates and applies these rates to its respective year-to-date taxable income or loss. The computation of the estimated effective tax rates at each interim period requires certain estimates and assumptions including, but not limited to, the expected operating income for the fiscal year, projections of the proportion of income (or loss) earned and taxed in the United States and foreign tax jurisdictions, along with permanent differences, and the likelihood of deferred tax asset utilization. The Company's estimates and assumptions may change as new events occur, additional information is obtained, or as the tax environment changes. Should facts and circumstances change during a period causing a material change to the estimated effective income tax rate, a cumulative adjustment will be recorded.

The income tax provisions for the six months ended June 30, 2019 and 2020 were based on the estimated annual effective income tax rates adjusted for discrete items occurring during the periods presented. During the six months ended June 30, 2019 and 2020, the Company recognized an aggregate consolidated income tax expense of \$5,119 and \$11,440, respectively, for U.S. domestic and foreign income taxes. During the six months ended June 30, 2019 and 2020, the Company recorded a discrete tax benefit of \$3,653 and \$6,423, respectively, associated with stock-based compensation. The effective income tax rate of 9.9% for the six months ended June 30, 2019 was lower than the effective income tax rate of 14.1% for the same period in the current year primarily as a result of a change in the timing and mix of U.S. and foreign income.

**Note 17: Fair Value of Financial Instruments*****Derivatives Not Designated As Hedging Instrument***

On March 31, 2020, the Company entered into an interest rate swap with a notional amount of \$200,000 and a ten-year term to reduce the interest rate risk associated with the Company's Credit Facility. The interest rate swap is not designated as a hedging instrument for accounting purposes. The Company accounts for the swap as either an asset or a liability on the balance sheet and carries the derivative at fair value. Gains and losses from the change in fair value are recognized in *Other income (expense), net* and payments related to the swap are recognized in *Interest expense, net* in the consolidated statements of operations. For the six months ended June 30, 2020, the Company recorded a loss of \$4,174 in *Other income (expense), net*, and total payments recognized in *Interest expense, net* related to the swap were \$110.

***Fair Value***

The Company applies the provisions of ASC Topic 820, *Fair Value Measurement*, for fair value measurements of financial assets and financial liabilities and for fair value measurements of non-financial items that are recognized or disclosed at fair value in the consolidated financial statements.

The Company's financial instruments include cash equivalents, account receivables, certain other assets, accounts payable, accruals, other current liabilities, and long-term debt.

The carrying values of the Company's financial instruments excluding long-term debt approximate their fair value due to the short-term nature of those instruments. Additionally, as of December 31, 2019 and June 30, 2020, the fair value of the Company's long-term debt approximated its carrying value based upon discounted cash flows at current market rates for instruments with similar remaining terms. The Company considers these valuation inputs to be Level 2 inputs in the fair value hierarchy. Considerable judgment is necessary to interpret the market data and develop estimates of fair values. Accordingly, the estimates presented are not necessarily indicative of the amounts at which these instruments could be purchased, sold, or settled.

## BENTLEY SYSTEMS, INCORPORATED AND SUBSIDIARIES

Notes to Consolidated Financial Statements (Continued)  
(in thousands, except share and per share data) (unaudited)

## Note 17: Fair Value of Financial Instruments (Continued)

A financial asset or liability classification is determined based on the lowest level input that is significant to the fair value measurement. The fair value hierarchy consists of the following three levels:

Level 1 inputs are quoted prices (unadjusted) in active markets for identical assets or liabilities.

Level 2 inputs are quoted prices for similar assets and liabilities in active markets or inputs that are observable for the asset or liability, either directly or indirectly through market corroboration, for substantially the full term of the financial instrument.

Level 3 inputs are unobservable inputs based on management's own assumptions used to measure assets and liabilities at fair value.

The following tables provide the financial assets and financial liabilities carried at fair value measured on a recurring basis:

December 31, 2019	Level 1	Level 2	Level 3	Total
<b>Assets:</b>				
Money market funds <sup>(1)</sup>	\$70,000	\$—	\$—	\$70,000
<b>Total assets</b>	<b>\$70,000</b>	<b>\$—</b>	<b>\$—</b>	<b>\$70,000</b>
<b>Liabilities:</b>				
Acquisition contingent consideration <sup>(2)</sup>	\$—	\$—	\$6,599	\$6,599
Deferred compensation plan <sup>(3)</sup>	2,544	—	—	2,544
<b>Total liabilities</b>	<b>\$2,544</b>	<b>\$—</b>	<b>\$6,599</b>	<b>\$9,143</b>
June 30, 2020	Level 1	Level 2	Level 3	Total
<b>Assets:</b>				
Money market funds <sup>(1)</sup>	\$61	\$—	\$—	\$61
<b>Total assets</b>	<b>\$61</b>	<b>\$—</b>	<b>\$—</b>	<b>\$61</b>
<b>Liabilities:</b>				
Acquisition contingent consideration <sup>(2)</sup>	\$—	\$—	\$5,761	\$5,761
Interest rate swap <sup>(4)</sup>	—	4,174	—	4,174
Deferred compensation plan <sup>(3)</sup>	2,250	—	—	2,250
<b>Total liabilities</b>	<b>\$2,250</b>	<b>\$4,174</b>	<b>\$5,761</b>	<b>\$12,185</b>

(1) Included in *Cash and cash equivalents* in the accompanying consolidated balance sheets.

(2) Included in *Accruals and other current liabilities* and *Other liabilities* in the accompanying consolidated balance sheets. Acquisition contingent consideration liability is measured at fair value and is based on significant inputs not observable in the market, which represents a Level 3 measurement within the fair value hierarchy. The valuation of contingent consideration uses assumptions the Company believes would be made by a market participant.

(3) Included in *Other liabilities*, except for current liabilities of \$153 and \$99 as of December 31, 2019 and June 30, 2020, respectively, which are included in *Accruals and other current liabilities* in the accompanying consolidated balance sheets.

(4) Included in *Other liabilities* in the accompanying consolidated balance sheets.



## BENTLEY SYSTEMS, INCORPORATED AND SUBSIDIARIES

Notes to Consolidated Financial Statements (Continued)  
(in thousands, except share and per share data) (unaudited)**Note 17: Fair Value of Financial Instruments (Continued)**

The following table is a reconciliation of the changes in fair value of the Company's financial liabilities which have been classified as Level 3 in the fair value hierarchy for the year ended December 31, 2019 and the six months ended June 30, 2020.

	Year Ended December 31, 2019	Six Months Ended June 30, 2020
Balance, beginning of year	\$ 4,316	\$ 6,599
Payments	(2,513)	(1,091)
Addition	4,498	1,706
Reclassification	180	—
Change in fair value	62	(1,390)
Foreign currency translation adjustments	56	(63)
Balance, end of period	<u>\$ 6,599</u>	<u>\$ 5,761</u>

The Company did not have any transfers between levels within the fair value hierarchy.

**Note 18: Commitments and Contingencies**

**Purchase Commitment**—In the normal course of business, the Company enters into various purchase commitments for goods and services. As of June 30, 2020, the non-cancelable future cash purchase commitment for services related to the provisioning of the Company's software solutions was \$93,400 through May 2023. The Company expects to fully consume its contractual commitment in the ordinary course of operations.

**Operating Leases**—The Company leases certain facilities, cars, and equipment under operating leases having initial or remaining non-cancellable terms in excess of one year. For details, see Note 8.

**Litigation**—From time to time, the Company is involved in certain legal actions arising in the ordinary course of business. In management's opinion, based upon the advice of counsel, the outcome of such actions is not expected to have a material adverse effect on the Company's future financial position or results of operations.

**Note 19: Geographic Data**

Revenues by geographic area are presented as part of the discussion in Note 3. The following table presents the Company's long-lived assets, net of depreciation and amortization by geographic region. See Note 5, Note 6, and Note 8 for further detail around these assets.

	As of December 31, 2019	As of June 30, 2020
Long-lived assets:		
Americas <sup>(1)</sup>	\$34,758	\$ 56,345
Europe, the Middle East, and Africa	34,039	56,889
Asia/Pacific	7,148	15,211
Total long-lived assets	<u>\$75,945</u>	<u>\$128,445</u>

(1) Americas includes the United States, Canada, and Latin America (including the Caribbean).

**BENTLEY SYSTEMS, INCORPORATED AND SUBSIDIARIES**

**Notes to Consolidated Financial Statements (Continued)**  
**(in thousands, except share and per share data) (unaudited)**

**Note 20: Interest Expense, Net**

Interest expense, net is comprised of the following:

	Six Months Ended June 30,	
	2019	2020
Interest expense	\$(5,021)	\$(2,846)
Interest income	547	330
<b>Total interest expense, net</b>	<b><u>\$(4,474)</u></b>	<b><u>\$(2,516)</u></b>

**Note 21: Other Income (Expense), Net**

Other income (expense), net is comprised of the following:

	Six Months Ended June 30,	
	2019	2020
Foreign exchange loss <sup>(1)</sup>	\$(1,588)	\$(4,263)
Other income (expense), net <sup>(2)</sup>	(159)	(2,722)
<b>Total other income (expense), net</b>	<b><u>\$(1,747)</u></b>	<b><u>\$(6,985)</u></b>

- (1) Foreign exchange loss is primarily attributable to foreign currency translation losses derived primarily from U.S. Dollar denominated cash and cash equivalents, account receivables, and intercompany balances held by foreign subsidiaries. For the six months ended June 30, 2019 and 2020, intercompany finance transactions denominated in U.S. dollars resulted in unrealized foreign currency translation losses of \$1,680 and \$1,765, respectively.
- (2) Other income (expense), net includes a loss from the change in fair value of the Company's interest rate swap of \$4,174, partly offset by a gain from the change in fair value of acquisition contingent consideration of \$1,390 for the six months ended June 30, 2020 (see Note 17).

**Note 22: Earnings Per Share**

Earnings per share ("EPS") of Class A and Class B Common Stock amounts are computed using the two-class method required for participating securities. The Company issues certain restricted stock awards determined to be participating securities because holders of such shares have non-forfeitable dividend rights in the event of the Company's declaration of a dividend for common shares. For the six months ended June 30, 2020, there were no participating securities outstanding.

Undistributed earnings allocated to participating securities are subtracted from net income in determining net income attributable to common stockholders. Basic EPS is computed by dividing net income attributable to common stockholders by the weighted-average number of shares of Class A and Class B Common Stock outstanding.

For the calculation of diluted EPS, net income attributable to common stockholders for basic EPS is adjusted by the effect of dilutive securities, including awards under the Company's equity compensation plans. Diluted EPS attributable to common stockholders is computed by dividing the resulting net income attributable to common stockholders by the weighted-average number of fully diluted common shares outstanding.

Except with respect to voting and conversion, the rights of the holders of the Company's Class A Common Stock and the Company's Class B Common Stock are identical. Each class of shares has the same

## BENTLEY SYSTEMS, INCORPORATED AND SUBSIDIARIES

Notes to Consolidated Financial Statements (Continued)  
(in thousands, except share and per share data) (unaudited)

## Note 22: Earnings Per Share (Continued)

rights to dividends and allocation of income (loss) and therefore, earnings per share would not differ under the two-class method. The details of basic and diluted EPS are as follows (in thousands, except per share amounts):

	Six Months Ended June 30,	
	2019	2020
<b>Numerator:</b>		
Net income	\$ 46,418	\$ 68,745
Less: Net income attributable to participating securities	(12)	—
Net income attributable to Class A and Class B common stockholders	\$ 46,406	\$ 68,745
<b>Denominator:</b>		
Denominator for basic net income per share — weighted average shares	285,529,476	286,068,766
Effect of dilutive securities:		
Stock options	8,103,779	9,526,468
Denominator for dilutive net income per share	293,633,255	295,595,234
<b>Net income per share, basic</b>	<b>\$ 0.16</b>	<b>\$ 0.24</b>
<b>Net income per share, diluted</b>	<b>\$ 0.16</b>	<b>\$ 0.23</b>

No shares were excluded from the computation of diluted net income per share attributable to common stockholders for the periods presented.

## Note 23: Subsequent Events

In preparing the consolidated financial statements as of and for the six months ended June 30, 2020, the Company evaluated subsequent events for recognition and measurement through August 7, 2020, the date when the consolidated financial statements were issued.

On July 10, 2020 and July 21, 2020, the Company granted a total of 179,188 shares of restricted stock and restricted stock units and 6,136 shares of restricted stock, respectively, under the Company's Equity Incentive Plan, at a grant date fair value of \$15.48 per share, all of which are subject to performance-based vesting as determined by the achievement of certain business growth targets which include growth in annual recurring revenues as well as actual bookings for perpetual licenses and non-recurring services. Annual performance targets are seasonalized and targets are set for quarterly and annual performance periods ending on December 31, 2020. These performance-based restricted shares and units carry dividend, but not voting rights. During the year ending December 31, 2020, the Company estimates it will recognize stock-based compensation expense associated with these awards ranging from \$1,721 up to \$2,869, with the upper end of the range assuming all performance conditions are achieved in 2020.

On July 10, 2020, the Company granted a total of 189,188 shares of restricted stock and restricted stock units under the Equity Incentive Plan at a grant date fair value of \$15.48 per share, of which 179,188 vest ratably on each of the first four anniversaries of the grant date and 10,000 vest ratably beginning on July 13, 2021 and on the three subsequent anniversaries of that date. These restricted shares and units do not have voting rights and any dividends declared accrue on such shares and are paid only upon vesting. The Company estimates the unrecognized stock-based compensation expense associated with these awards to be \$2,929, which is expected to be recognized over the four-year vesting period.

**BENTLEY SYSTEMS, INCORPORATED AND SUBSIDIARIES****Notes to Consolidated Financial Statements (Continued)**  
**(in thousands, except share and per share data) (unaudited)****Note 23: Subsequent Events (Continued)**

On July 10, 2020, the Company granted a total of 994,912 shares of restricted stock and restricted stock units, including 32,238 restricted stock units that will be settled in cash, under the Equity Incentive Plan at a grant date fair value of \$15.48 per share, which vest upon the earlier of the Company's successful completion of its initial public offering or December 31, 2020. These restricted shares and units do not have voting or dividend rights, except in the case of any extraordinary dividend (as described in the Equity Incentive Plan) declared by the Company, if any, which would accrue on such shares and be paid only upon vesting. During the year ending December 31, 2020, the Company estimates it will recognize \$14,902 of stock-based compensation expense for the equity-settled awards and compensation expense for the cash-settled awards in an amount equal to the Company's initial public offering price multiplied by the number of cash-settled awards outstanding at the time of the initial public offering. This latter expense is not readily determinable as of the date hereof.

On July 21, 2020, the Company granted a total of 1,020,472 shares of restricted stock and restricted stock units including 46,300 restricted stock units that will be settled in cash, under the Equity Incentive Plan at a grant date fair value of \$15.48 per share, which vest ratably on each of the first four anniversaries of the grant date. These restricted shares and units do not have voting rights and any dividends declared accrue on such shares and are paid only upon vesting. The Company estimates the unrecognized stock-based compensation expense associated with the equity-settled awards to be \$15,080, which is expected to be recognized over the four-year vesting period. The Company is not able to estimate the compensation expense associated with the cash-settled awards, which will be recognized in an amount equal to the number of cash-settled awards outstanding at vesting multiplied by the applicable fair market value of the Company's shares at the time of vesting.

***Event Subsequent to Issuance of the Consolidated Financial Statements***

On September 2, 2020, the Company entered into the First Amendment to the Credit Facility. The First Amendment provided a New Term Loan of \$125,000 with a maturity of December 18, 2022 and included certain other amendments, including the addition of a mandatory prepayment provision requiring the Company to prepay borrowings under the Credit Facility in an aggregate amount equal to the net proceeds from any underwritten public offering by the Company, which prepayment shall be applied, first, to the New Term Loan and, second, to any borrowings outstanding under the revolving facility under the Credit Facility without reducing the revolving commitments thereof. The Company used borrowings under the New Term Loan and under the revolving facility under the Credit Facility to pay the Special Dividend of \$1.50 per share of common stock (approximately \$390,000 in the aggregate).



**Goldman Sachs & Co. LLC**

**BofA Securities**

**RBC Capital Markets**

**Baird**

**KeyBanc Capital Markets**

**Mizuho Securities**

**Through and including October 17, 2020 (the 25th day after the date of this prospectus), all dealers effecting transactions in these securities, whether or not participating in the offering, may be required to deliver a prospectus. This is in addition to a dealer's obligation to deliver a prospectus when acting as an underwriter and with respect to an unsold allotment or subscription.**

---

---